

Instructions

Eagle Quantum Premier®
12 Channel High Speed
Deluge Module (HSDM)
EQ3780HSDM



Table of Contents

1.0	DESCRIPTION	1
2.0	THEORY OF OPERATION	1
3.0	FEATURES	2
4.0	SPECIFICATIONS	2
5.0	HSDM CONFIGURATION	4
5.1	Inputs	4
5.1.1	Configuration of HSDM Input Channels	4
5.2	Outputs	5
5.2.1	Configuration of HSDM Output Channels	5
5.3	Cascade Configuration	6
5.3.1	Example #1	7
5.3.2	Example #2	7
6.0	HSDM OPERATION	8
7.0	INSTALLATION OPTIONS	8
8.0	WIRING CONNECTIONS	8
8.1	Unsupervised Inputs	8
8.2	Supervised Inputs	8
8.3	Unsupervised Outputs	9
8.4	Supervised Outputs	9
8.5	Cascaded Wiring Connections	11
8.6	Physical Disconnect Switch	11
9.0	COMMISSIONING	15
10.0	SERVICING	15
11.0	TROUBLESHOOTING	15
11.1	Voltage Fault Conditions	16
12.0	ORDERING INFORMATION	16
13.0	DEVICE RETURN AND REPAIR	16
	MODEL MATRIX	16

INSTRUCTIONS

Eagle Quantum Premier® 12 Channel High Speed Deluge Module (HSDM) EQ3780HSDM



1.0 DESCRIPTION

The EQ3780HSDM High Speed Deluge Module (HSDM) is specifically designed to expand the capability of the Det-Tronics Eagle Quantum Premier® (EQP) System by providing the capability to activate ultra-high speed suppression systems for hazardous applications such as munitions manufacturing.

The HSDM provides up to six (6) configurable input channels and up to six (6) configurable output channels that can be programmed for supervised or unsupervised operation. Typical initiating devices include optical flame detectors, heat detectors, and manual pull stations. Output channels are designed to activate Factory Mutual (FM) approved solenoids. Solenoids that are activated by the HSDM are typically used to initiate pilot-actuated deluge valves.

A unique cascade output feature allows the output of the HSDM to be connected to the input of another HSDM, extending the systems capability to activate multiple solenoids with a single input.

An LED indicator is provided that indicates normal or fault status of the entire HSDM. Additionally, each input and output channel of the HSDM is provided with LED indicators for normal, active and fault conditions.

The HSDM can be mounted directly to a panel, or it can be DIN rail mounted. System status can be determined using the system status indicators that are resident on the module and the Eagle Quantum Premier Safety System Software (S3).

2.0 THEORY OF OPERATION

The HSDM is designed to have a typical independent response time of 2 milliseconds (mS). Timing is established from when a valid input is detected until the output is active. A proprietary signal processing algorithm is utilized to detect a valid input and mitigate potential activation from extraneous sources.

The HSDM ensures proper system operation through continuous supervision of all inputs and outputs. A Local Operating Network/Signaling Line Circuit (LON/SLC) provides ANSI/NFPA 72 Class X monitoring for the connection between the HSDM and the EQP Safety System Controller.

Each HSDM input channel accepts contact closures from fire detection devices such as optical flame detectors, heat detectors, and manual pull stations. Output channels are designed to activate Factory Mutual (FM) approved solenoids that are used to initiate pilot-actuated deluge valves. To ensure reliable system operation, the module can continuously monitor its input and output circuits for open and short circuit conditions.

The HSDM resides as a device on the EQP LON/SLC and reports to the EQP Controller on a periodic basis. The EQP controller continuously monitors the status of the HSDM. The EQP I/O can be utilized by the controllers static and user configured logic functions. The EQP system can be used to activate notification appliances and also can be interfaced with plant wide communication systems to allow full communication of status and alarm conditions. The HSDM supports ANSI/NFPA 72 Class X monitoring with the Eagle Quantum Premier Controller.

3.0 FEATURES

- Typical 2mS independent response time
- Uniquely programmable outputs - one-to-one, one-to-many, or many-to-one
- Cascade capability
- Internal independent logic capabilities
- RFI and EMI hardened (CE Marked and Maritime Compliant)
- Expands the capabilities of the Det-Tronics Eagle Quantum Premier® system
- Provides up to six (6) Class B Input Channels (Supports Class A wiring when two input channels are combined)
- Provides up to six (6) Class B Output Channels (Supports Class A wiring when two output channels are combined)
- Input and Output channels are configurable as supervised or unsupervised points
- Output Channels are capable of continuously driving 2A at 30Vdc, up to a maximum of 10A per module
- Individual channel LEDs indicate Normal, Active, and Fault status
- Provides remote I/O capabilities via LON/SLC
- Panel or DIN rail mounting
- Module level status LED indicator
- Plug-in wiring connectors
- Meets the requirements of NFPA 72
- FM, CSA, ATEX, IECEx, Exida, and DNV-GL certified
- SIL 2 rated per IEC 61508 Series

4.0 SPECIFICATIONS

POWER REQUIREMENTS—

3.0 Watts maximum consumption at 30 Vdc with all inputs and outputs active (output load requirements not included).

INPUT VOLTAGE—

24 Vdc nominal at HSDM, 18 to 30 Vdc
0.05 Vac maximum AC ripple.

NOTE

The HSDM provides input voltage monitoring to ensure proper operation of the connected output solenoid.

SLC OUTPUT—

Digital communication, transformer isolated (78.5 kbps).

TEMPERATURE RANGE—

Operating: -40°C to $+75^{\circ}\text{C}$ (-40°F to $+167^{\circ}\text{F}$).
Storage: -55°C to $+85^{\circ}\text{C}$ (-67°F to $+185^{\circ}\text{F}$).

HUMIDITY RANGE—

5 to 95% RH, non-condensing.

VIBRATION—

DNVGL-CG-0339 (Class A).

DIMENSIONS—

Refer to Figure 1.

SHIPPING WEIGHT—

1 lbs. (0.45 kg).

CERTIFICATION—

SIL: IEC 61508:2010.
Certified SIL 2 Capable.
Refer to the SIL 2 Certified .
EQP Safety Manual (95-8599).



FM / CSA: Class I, Div. 2, Groups A, B, C, D (T4).
Class I, Zone 2, Group IIC (T4).



ATEX/CE: ATEX/EMC Directive Compliant.
II 3 G
Ex nA nC IIC T4 Gc
UL 20 ATEX 138864X
Tamb = -40°C to $+75^{\circ}\text{C}$.



IECEX: IECEx UL 20.0112X.
Ex nA nC IIC T4 Gc.
Tamb = -40°C to $+75^{\circ}\text{C}$.



SPECIAL CONDITIONS FOR SAFE USE 'X'—

a) The controller and modules shall be used in an area of no more than pollution degree 2, conforming to IEC/EN 60664-1, and in an enclosure with a tool removable cover, that complies with all relevant requirements of IEC/EN 60079-15, rated at least IP54, and be connected to supply circuits where the rated voltage cannot be exceeded by 140% caused by transient disturbances.

b) Output channels are capable of continuously driving 2A at 30 Vdc, up to a maximum of 10A per module.

INPUT CIRCUITS

UNSUPERVISED INPUT—

Two state input (on/off).
Normally open contact.

SUPERVISED INPUT (Open Circuit)—

For Class A and Class B wiring.

Two state input (active/trouble):

- End of Line Resistor 10 K ohms nominal
- Open Circuit > 45 K ohms
- Active Circuit < 5 K ohms

SUPERVISED INPUT (Open and Short Circuit)—

For Class A and Class B wiring.

Three State input (active/short/open.)

- End of Line Resistor 10 K ohms nominal
- In Line Resistor 3.3 K ohms nominal
- Open Circuit > 45 K ohms
- Short Circuit < 250 ohms
- Active Circuit 480 ohms to 5 K ohms.

INPUT, TYPES—

Configurable for static logic applications:

- Fire Alarm
- Supervisory
- Trouble
- Other.

For Class A wiring on inputs, configure adjacent channels for Class A wiring and connect both channels to single contact device(s).

OUTPUT / RELEASING OR UNSUPERVISED DEVICE CIRCUITS

UNSUPERVISED OUTPUT RATING (Per Channel)—
2 amperes max per channel, 10 amperes max per device at 30 Vdc maximum.

NOTE

Voltage available at outputs is dependent on input voltage ($V_{out} \approx V_{in} - 0.7 \text{ Vdc}$).

OUTPUT—

Form "A" normally off.

RESPONSE TIME—

Output typically actuates in <0.002 second after detecting a valid input.

EOL RESISTORS—

10 K ohms. Each input and output circuit must have an EOL resistor when supervision is required.

SUPERVISED OUTPUT RATING—SIGNALING CIRCUIT, CLASS A AND CLASS B WIRING

MAXIMUM OUTPUT CURRENT (Per Channel)—

2 amperes max per channel, 10 amperes max per device at 30 Vdc maximum.

SUPERVISORY CURRENT (Per Channel)—

Monitored at 5.3 mA, $\pm 0.2 \text{ mA}$.

RESPONSE TIME—

Output typically actuates in <0.002 second after detecting a valid input.

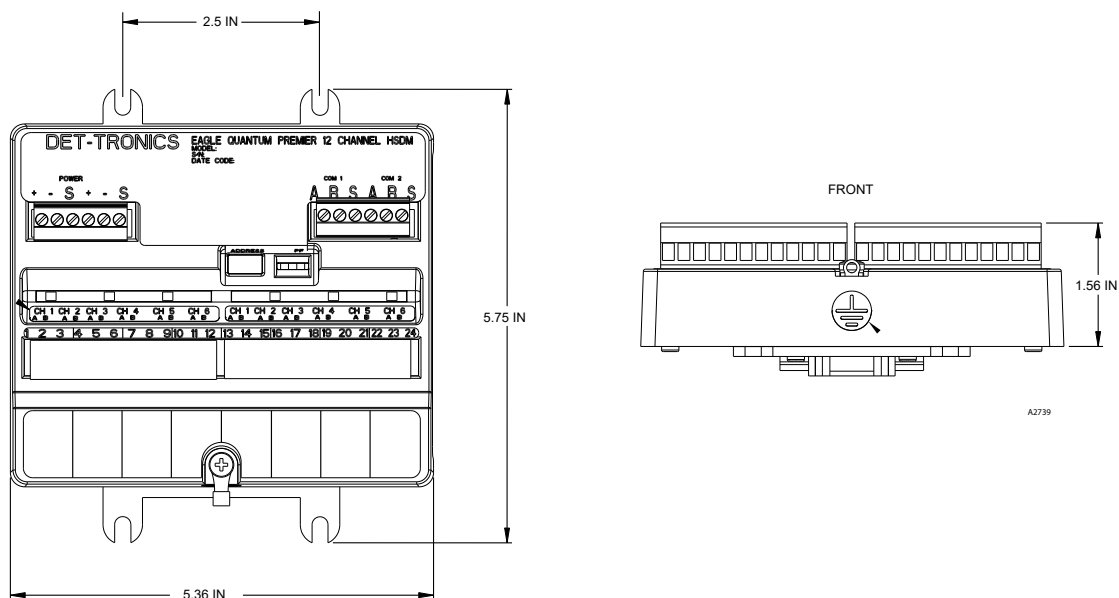

Figure 1—Dimensions and Mounting Location of the HSDM Module in Inches

RELEASING OUTPUT TYPES—

Configurable for device applications:

- Continuous
- Timed.

For Class A wiring on outputs, configure adjacent channels for Class A wiring and connect both channels to single output device(s).

INPUT WIRE SPECIFICATIONS—

Maximum cable capacitance must be less than 15nF. Maximum distance of 1500 feet (457 meters) from initiating device to HSDM input.

Terminals accept maximum 12 AWG (2.5mm²) wire. Terminal screw torque is 0.5-0.6 Nm (4.4-5.3 lb-in). For ambient temperatures below -10°C use field wiring suitable for the expected conditions, and for ambient temperatures above 60°C, use field wiring suitable for 20°C above maximum expected conditions.

Follow all local codes and best practices.

OUTPUT WIRE SPECIFICATIONS—

Terminals accept maximum 12 AWG (2.5mm²) wire. Terminal screw torque is 0.5-0.6 Nm (4.4-5.3 lb-in). For ambient temperatures below -10°C use field wiring suitable for the expected conditions, and for ambient temperatures above 60°C, use field wiring suitable for 20°C above maximum expected conditions.

Follow all local codes and best practices.

Refer to Figure 14 and Table 1 to determine maximum distance.

5.0 HSDM CONFIGURATION

5.1 INPUTS

Each input channel on the HSDM accepts a contact closure from normally open dry contacts. Inputs typically come from approved ultra-high-speed optical flame detectors and manual pull stations.

A unique network address must be assigned to each HSDM that resides on the LON SLC. The address is set by the 8 switch DIP switch assembly on the module. When using the switches located on the HSDM, the address is binary coded and is the sum of all switches placed in the “closed” position. Select the desired address and set the DIP switch for the correct binary value - See Figure 2.

Det-Tronics Safety System Software (S3), is used to configure other parameters of the HSDM - See Figure 3.

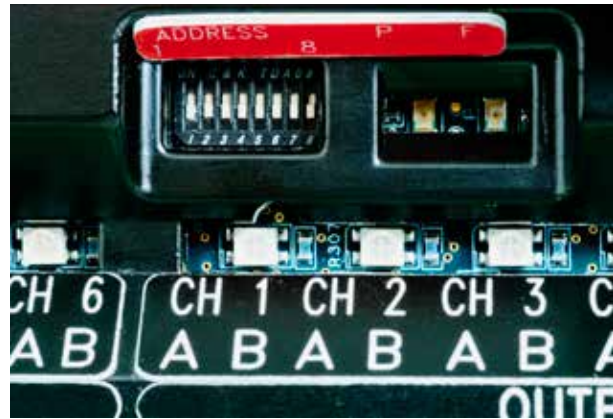

Figure 2—DIP Switch Location

5.1.1 Configuration of HSDM Input Channels

Tag Name: The Input Channel Tag Name must be created during initial configuration for any used input channels. No spaces are allowed. If the Input Channel is not used, it is not necessary to create a Tag Name for it. The Tag Name field is limited to a maximum of twenty (20) characters.

Description: A description for the input channel can be created and entered into this field. The Description field is limited to a maximum of forty-two (42) characters.

Wiring Method: The wiring method for each input that will be used must be selected. Choices include the following: Input not used, Class B, Class A, Unsupervised, or Cascade. The default wiring method is Input not used. Input circuits can be configured as unsupervised, although this configuration option does not comply with NFPA 72 code requirements.

When the Class A wiring method is selected, two input channels are combined thereby allowing the HSDM to support up to three Class A input circuits.

Supervision: A default wiring Supervision method for each input is automatically provided by the 12 Channel HSDM SIL Editor and is dependent upon the wiring method that is selected. Options for the supervision of the HSDM input channel wiring are shown below:

Wiring Method	Supervision
Input not used	None
Class B	Opens (default), Opens/Shorts (optional)
Class A	Opens (default), Opens/Shorts (optional)
Unsupervised	None
Cascade	Opens (default)

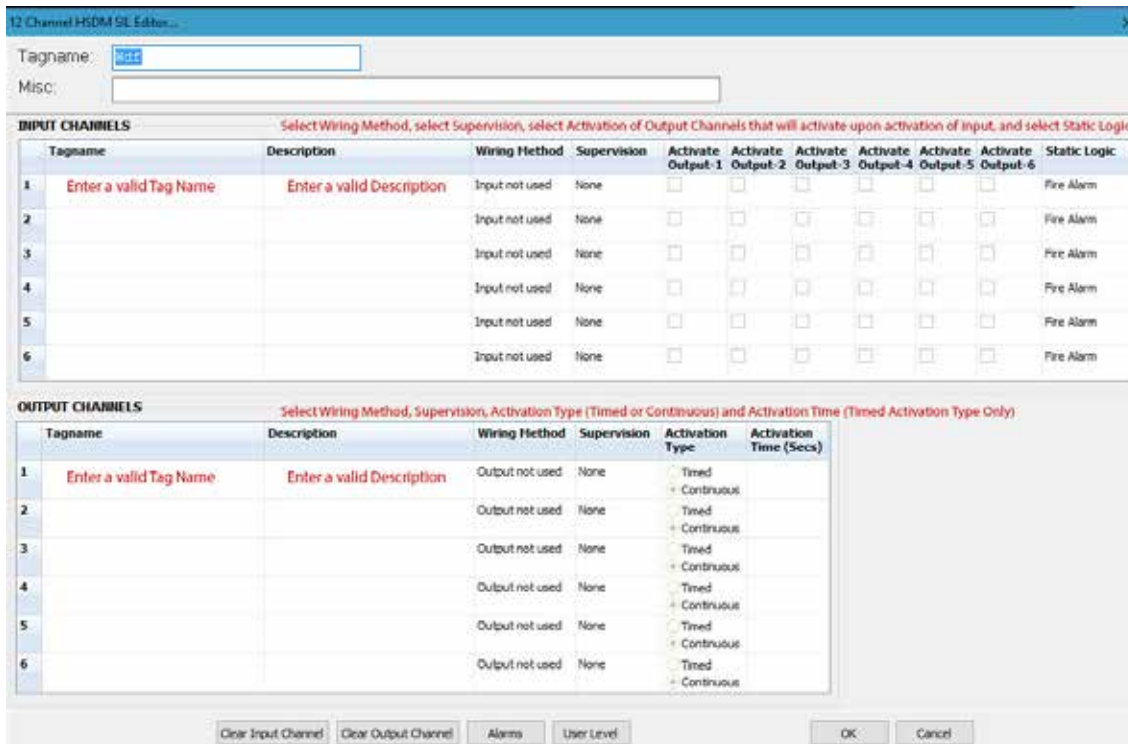

Figure 3—HSDM Configuration in S3

Selection of Output Channel Activation: For each input channel that is utilized, the number of outputs that are desired to activate upon a change to the input state must be selected. Up to six (6) outputs can be directed to activate with each input.

Static Logic: The HSDM is configurable for the following static logic applications:

- Fire Alarm (default)
- Trouble
- Supervisory
- Other

5.2 OUTPUTS

Output channels are designed to activate FM approved solenoids. Each output can continuously provide a maximum of 2 Amperes at 30 Vdc, up to a maximum of 10A per module. Det-Tronics Safety System Software (S3), is used to configure the HSDM - See Figure 3.

5.2.1 Configuration of HSDM Output Channels

Tag Name: The Output Channel Tag Name must be created during initial configuration for any used output channels. No spaces are allowed. If the output channel is not used, it is not necessary to create a Tag Name for it. The Tag Name field is limited to a maximum of twenty (20) characters.

Description: A description for the output channel can be created and entered into this field. The Description field is limited to a maximum of forty-two (42) characters.

Wiring Method: The wiring method for each output that will be used must be selected. Choices include the following: Output not used, Class B, Class A, Unsupervised, or Cascade. The default wiring method is Output not used. Output circuits can be configured as unsupervised, although this configuration option does not comply with NFPA 72 code requirements.

When the Class A wiring method is selected, two output channels are combined. The HSDM can support up to three Class A output circuits.

NOTE

HSDM's that are configured to cascade must be operated from the same power supply. It is recommended that no more than 60 modules be connected to a single power supply.

Supervision: A default wiring supervision method for each Output Channel is automatically provided by the 12 channel HSDM SIL Editor and is dependent upon the wiring method that is selected.

Options for the wiring supervision of the HSDM output channels are shown in the following table:

Wiring Method	Supervision
Output not used	None
Class B	Opens (default), Opens/Shorts (optional)
Class A	Opens (default), Opens/Shorts (optional)
Unsupervised	None
Cascade	None*

* Output is supervised by corresponding HSDM input channel connection.

Activation Type: If the output channel is used, the Activation Type (Timed or Continuous) must be selected. The default Activation Type is Continuous.

Continuous: If the Continuous Activation Type is selected, once the output is activated it will remain active, providing voltage at the output terminals until it is reset using S3, EQP logic, through the EQP faceplate menu, or power is removed from the HSDM.

Timed: If the Timed Activation Type is selected, a default activation time of 900 seconds (15 minutes) will appear. Enter the desired activation time in seconds in the range of 1-18,000 seconds (up to 5 hours). The timed output function begins when the input returns to a non-active state. The output channel will remain active until the activation time is reached.

NOTE

NFPA 72 does not allow a timed activation of less than 15 minutes.

5.3 CASCADE CONFIGURATION

If more than six (6) solenoids are required to be activated with a given input, a unique Cascade output feature is available that allows a single HSDM input to activate additional HSDM outputs. An output from one HSDM can be configured to cascade to the input of another HSDM providing a Class B wiring method.

The second HSDM is configured to activate its output(s) upon receiving the cascaded input signal. Typically, an additional 2mS response time must be accounted for on each HSDM cascade circuit. For example, a single optical flame detector is connected to the input of HSDM-1. Five outputs from HSDM-1 are connected to five solenoids that are used to activate five pilot-actuated deluge nozzles. The sixth output from the HSDM-1 is connected via a single wire to an Input Channel of HSDM-2.

All HSDM-2 outputs can be used to activate up to six solenoids. It can be assumed that the solenoids that are activated by the HSDM-2's outputs will typically experience an additional 2mS activation time when compared against the outputs from HSDM-1.

In some instances, it may be necessary to configure multiple HSDMs in a cascade configuration with a single input that activates multiple solenoids. Two examples are provided which demonstrate how multiple solenoids can be activated by a single input.

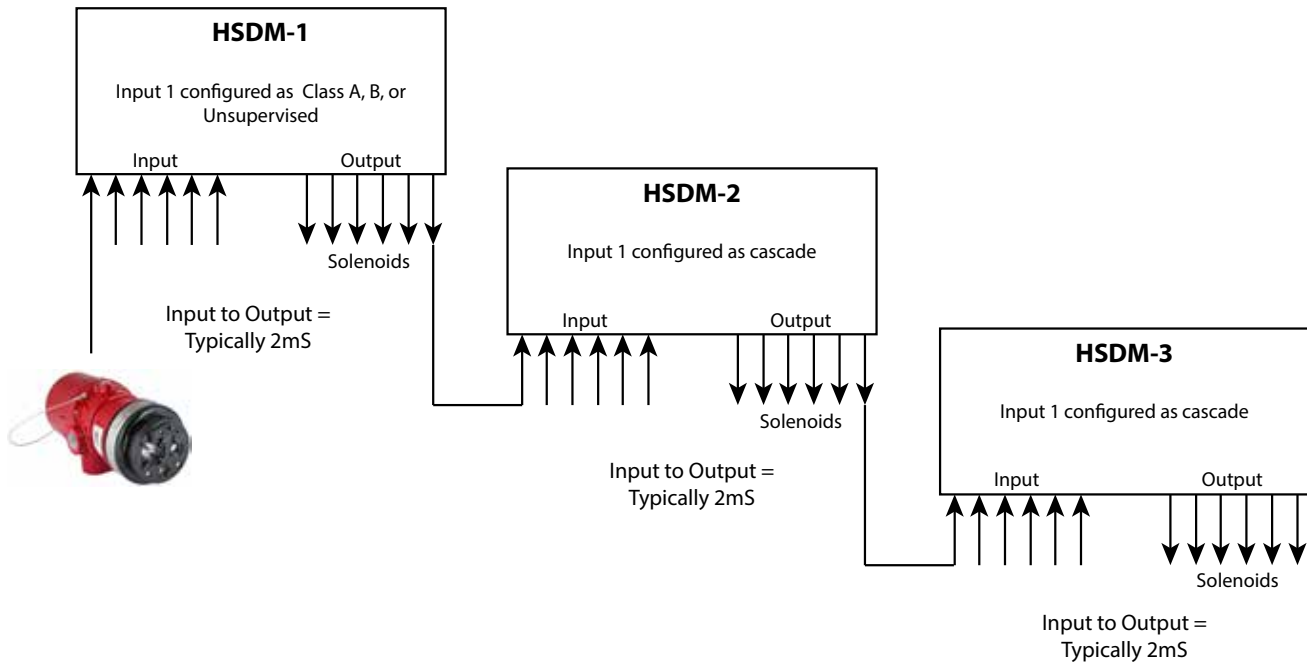

Figure 4—HSDM Cascade Example #1

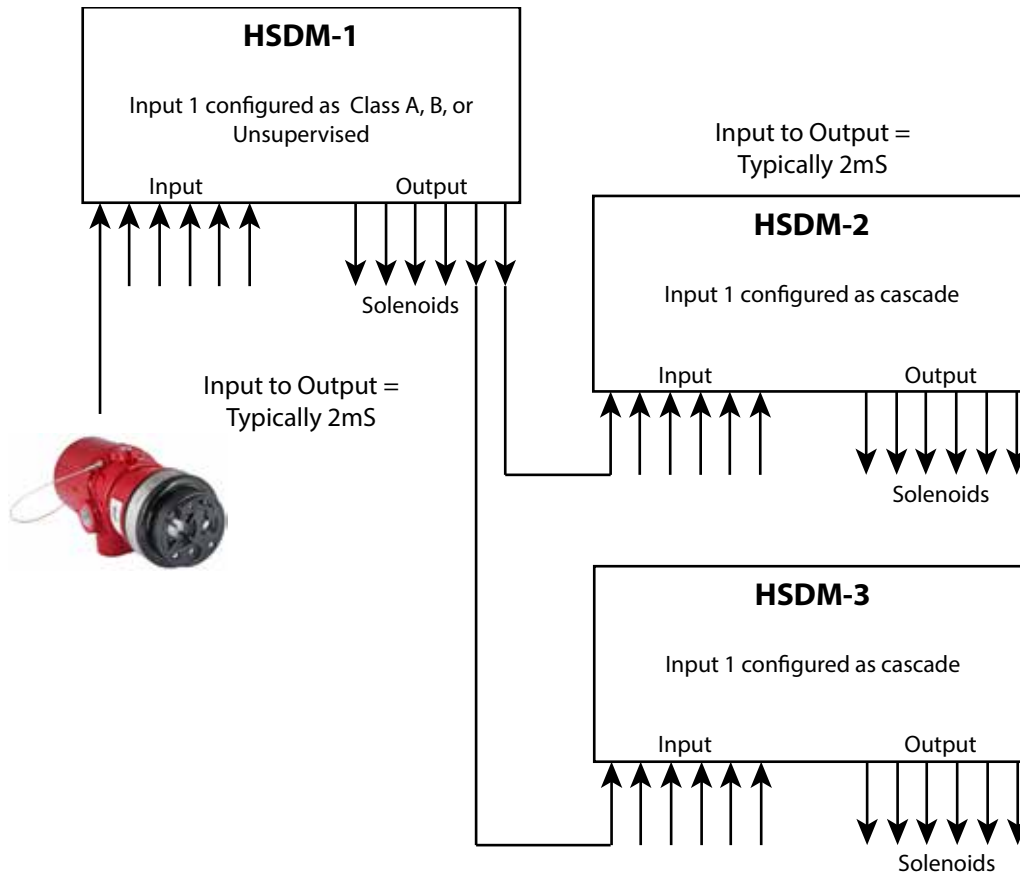

Figure 5—HSDM Cascade Example #2

5.3.1 HSDM Cascade Example 1

In the example portrayed in Figure 4, the activation of an input on HSDM-1 will result in the activation of five (5) solenoids typically within 2mS of the initial activation, five (5) additional solenoids typically within 4mS from the initial activation, and an additional six (6) solenoids typically within 6mS from the initial activation. A description of the sequence of events follows:

- Input 1 of HSDM-1 active, validated input detected
- Typical 2mS activation time
- 24 Vdc applied at all six outputs of HSDM-1:
 - Five solenoids activate
 - Input 1 of HSDM-2 active, validated input detected
- Typical 2mS activation time
- 24 Vdc is applied to all six outputs of HSDM-2:
 - Five solenoids activate
 - Input 1 of HSDM-3 active, validated input detected
- Typical 2mS activation time
- 24 Vdc applied at all six outputs of HSDM-3:
 - Six solenoids activate

5.3.2 HSDM Cascade Example 2

In the example portrayed in Figure 5, the activation of an input on HSDM-1 will result in the activation of four (4) solenoids typically within 2mS of the initial activation and an additional twelve (12) solenoids typically within 4mS from initial activation. A description of the sequence of events follows:

- Input 1 of HSDM-1 active, validated input detected
- Typical 2mS activation time
- 24 Vdc applied at all six outputs of HSDM-1:
 - Four solenoids activate
 - Input 1 of HSDM-2 and HSDM-3 active, validated input detected
- Typical 2mS activation time
- 24 Vdc applied at all six outputs of HSDM-2 and all six outputs of HSDM-3:
 - Six solenoids activate via HSDM-2 and six solenoids activate via HSDM-3

6.0 HSDM OPERATION

Power Up: Upon power up, an internal automatic test routine is executed. During this test routine, the Input and Output channel LED's are cycled in channel sequence from red, to green, to yellow. After this initial LED cycle the LEDs will display the value of the LON address for a few seconds. If all initialization tests pass, the HSDM will begin to supervise the input and output circuits according to its configuration and the LED's for the Input and Output channels will indicate the current status as indicated below:

Green: Normal Condition

Yellow: Trouble / Fault Condition

Red: Active Condition

7.0 INSTALLATION OPTIONS

The HSDM may be installed using DIN rail or it can be panel mounted for configurations requiring installation in NEMA or IP enclosures. DIN rail and mounting clip options must be specified at the time of order. Refer to the "Specifications" section for mounting arrangements and dimensions.

8.0 WIRING CONNECTIONS

All electrical connections are made to the field wiring connectors furnished with the module. Refer to Figure 3 for identification of module wiring terminals. Two examples of typical wiring applications have been provided in Figures 15 and 16.

Power Connector, Terminals 1 to 6 24 Vdc Power Input

Be certain to observe polarity and connect the DC power supply to terminals 1 and 2 of the module. If additional terminals are required for powering other devices, these devices should be connected to terminals 4 and 5. Shields are to be connected to terminals 3 and 6 — chassis (earth) ground terminals. Terminals are rated for 10 amperes. Use both sets of input terminals in parallel if total output current can exceed 10 amperes.

NOTE

No more than 60 LON devices should be connected to a single power supply to ensure proper HSDM circuit supervision.

COM 1 & COM 2 Connector, Terminals 1 to 6 LON/SLC Signaling Circuit Terminals

Be sure to observe polarity when wiring the LON/SLC. Shield connection — terminals 3 and 6.

- 1 — "A" side of signaling circuit for COM 1
- 2 — "B" side of signaling circuit for COM 1
- 4 — "A" side of signaling circuit for COM 2
- 5 — "B" side of signaling circuit for COM 2

Input Connector, Terminals 1 to 12 Terminals A & B

Channels 1 to 6 Input Terminals

Refer to individual wiring configurations for terminal descriptions. Only channel 1 is shown in each diagram. The information is typical for channels 2-6.

See Figures 15 and 16 for wiring diagrams for wiring to a Det-Tronics flame detector.

Output Connector, Terminals 1 to 12 Terminals A & B

Channels 1 to 6 Output Terminals

Refer to individual wiring configurations for terminal descriptions. Only channel 1 is shown in each diagram. The information is typical for channels 2-6.

See Figures 11 and 12 for wiring diagrams to a solenoid.

8.1 UNSUPERVISED INPUTS

Connect external system wiring to the appropriate terminals on the terminal block. See Figure 6. The input to the HSDM consists of a set of normally open contacts. An EOL resistor is not required.

8.2 SUPERVISED INPUTS

Opens Only Circuit Supervision:

Connect external system wiring to the appropriate terminals on the terminal block. For Class B wiring, see Figure 7. For Class A wiring, see Figure 8, noting that two channels are used for one Class A circuit. The input to the HSDM module consists of a set of normally open contacts, with a 10 K ohm, 1/4 watt EOL resistor in parallel across the set of contacts.

Opens and Shorts Circuit Supervision:

Connect external system wiring to the appropriate terminals on the terminal block. For Class B wiring, see Figure 9. For Class A wiring, see Figure 10, noting that two channels are used for one circuit. The input to the HSDM module consists of a set of normally open contacts, with a 10 K ohm, 1/4 watt EOL resistor in parallel across the set of contacts, and a 3.3 K ohm, 1/4 watt resistor in series with the set of contacts.

Input — Deluge and Pre-Action Sprinkler Systems

In order to comply with FM standard 1011/1012/1013 requirements, the initiating device circuit(s) for use with deluge and pre-action system configurations must

use Class A wiring or be wired within 20 feet (6.1 m) and in conduit from the HSDM. See Table 1 for a list of FM Approved solenoids for deluge and pre-action applications.

8.3 UNSUPERVISED OUTPUTS

Connect external system wiring to the appropriate terminals on the terminal block. See Figure 6. An EOL resistor is not required.

8.4 SUPERVISED OUTPUTS

Output - Deluge and Pre-Action Circuits

The output of the HSDM supervises the releasing circuit via the coil of the releasing solenoid. To maintain FM approval, it is essential to utilize a solenoid that is approved for use with the HSDM. This type of output does not require the use of EOL resistors or diodes to supervise the circuit - see Figures 11 and 12. To ensure adequate operating voltage for the output device, the maximum wiring length from the power source to the output device must not exceed the values shown on Table 1 for deluge and pre-action applications with calculated field wiring distance.

For solenoids, this wire length includes both the wiring from the power supply to the HSDM and the wiring from the module to the solenoid.

NOTE

For FM system approval listing, pre-action and deluge applications require that only FM compatibility approved solenoids can be wired into the HSDM outputs. Solenoids must utilize 24 Vdc and must not exceed 2 amperes current draw.

NOTE

Shunt/Flyback diodes do not need to be installed across the solenoid coil as internal circuit protection is provided within the HSDM.

To ensure proper operating performance, the input voltage at the HSDM must be 24 Vdc (nominal) and the maximum wiring length must not exceed the values shown in Table 1 for deluge and pre-action applications. Per NFPA 72 requirements, the secondary power must provide capacity for a 24 hour minimum standby operation, followed by a minimum of 15 minutes of releasing and alarm operation. Per FM Approval pre-action/deluge releasing requirements, the secondary power must provide capacity for a 90 hour minimum standby operation followed by a minimum of 5 minutes of releasing and alarm operation. In order to comply with NFPA 72 code requirements, the initiating device circuit(s) for use with deluge and pre-action system configurations must use Class A wiring or be wired in conduit within 20 feet from the HSDM.

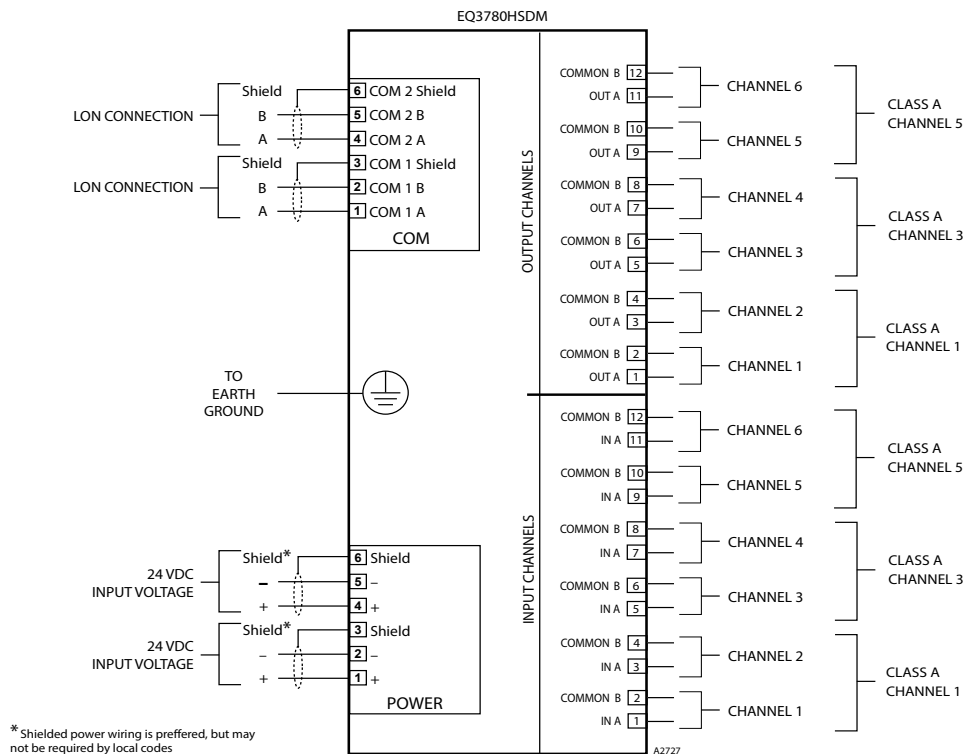

Figure 6—HSDM Module Wiring Terminals

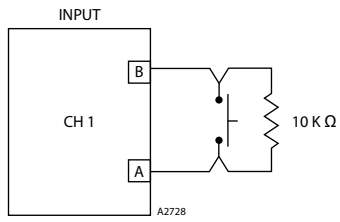

Figure 7—Supervised Input Configuration (Opens Only) – Class B

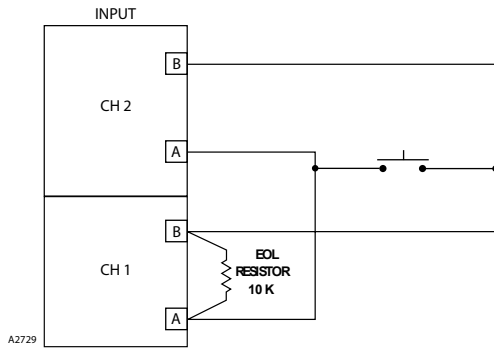

Figure 8—Supervised Input Configuration (Opens Only) – Class A

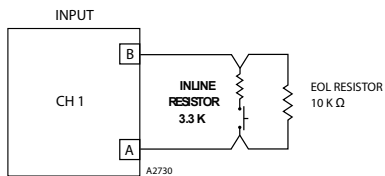

Figure 9—Supervised Input Configuration (Opens and Shorts) – Class B

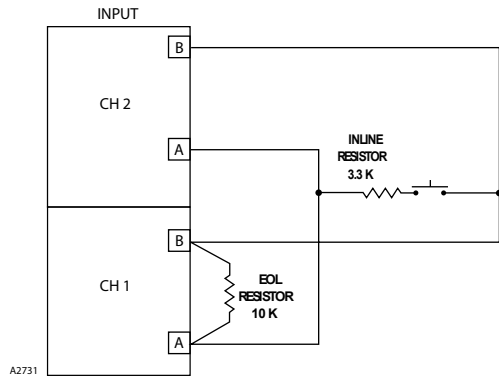
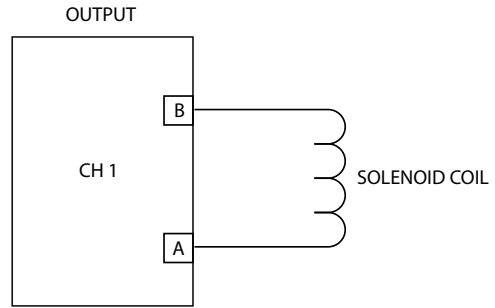

Figure 10—Supervised Input Configuration (Opens and Shorts) – Class A



NOTE: SHUNT/FLYBACK DIODES DO NOT NEED TO BE INSTALLED ON THE FIELD DEVICE. CIRCUIT PROTECTION IS PROVIDED WITHIN THE HSDM MODULE.

Figure 11—Supervised Output Configuration — Class B

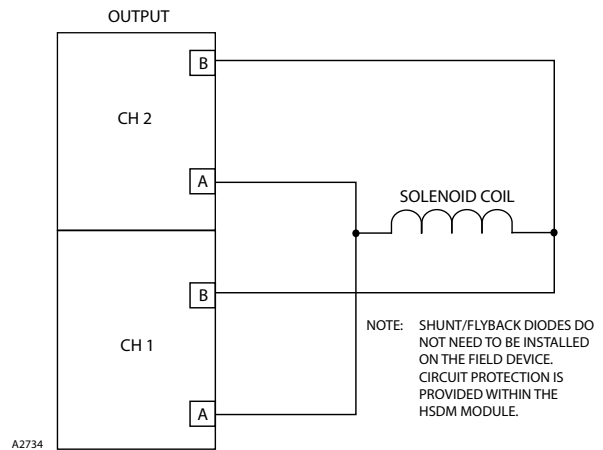

Figure 12—Supervised Output Configuration — Class A

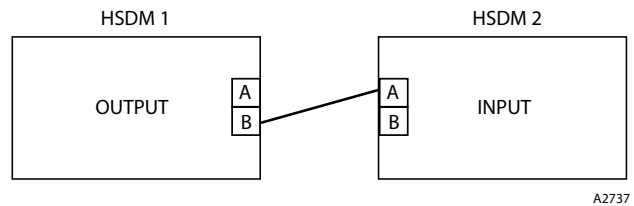

Figure 13—Configuration for Cascaded Wiring Connection

Table 1—Maximum Wire Length for FM Approved Solenoids for Deluge and Pre-Action Applications

I _{sol} Table 1		
Manufacturer	Part Number	I _{sol} (mA _{dc}) @ 24 Vdc
ASCO RedHat**	EF8210G002	483
Parker (Viking)	11591 C	416
Parker (Viking)	11592 C	416
Parker (Viking)	71395SN2ENJ1NOH111C2	416
Parker (Viking)	73218BN4UNLVNOC111C2	410
Parker (Viking)	73218BN4TNLVNOC322C2	830
Parker (Viking)	73218BN4TN00NOC111C2	416
ASCO RedHat	R8210A107	700
ASCO RedHat	8210A107	700
ASCO RedHat	8210G207	440
ASCO RedHat Cat#	11601	338
Viking PN	HV2740607 NC	
Viking PN	HV274608 NC	338
ASCO RedHat Cat #	11602	
Kidde-Fenwal	897494	1375
Cat #	202-749-260563	
Kidde-Fenwal	895630	2000
Cat #	81-895630-000	
Kidde-Fenwal	890181	2000
Det-Tronics PN	00219-209	
Ansul	570537	250
Macron	304.209.001	

*Note: Alternate secondary power source when accepted by local authority having jurisdiction may increase permissible wire voltage drops. Actual secondary voltage must be determined. Voltage and current at solenoid must be known and used in the equation.

**Hazardous location suitability by UL.



The following is based on Eq21xxPS (Primary Source) and Battery (Secondary Source)

$$\text{Total wire voltage drop} = 0.7 \text{ Vdc (MAX)} = VL_a + VL_b^*$$

$$VL_a = I_{\text{HSDM}} \times RL_a \quad I_{\text{HSDM}} = \text{Total current of HSDM and all active outputs}$$

$$VL_b = I_{\text{sol}} \times RL_b \quad I_{\text{sol}} \text{ see Table 3-10}$$

$$RL_a \& RL_b = \text{wire resistance} = \Omega \text{ per foot} \times 2 \text{ (x2 = B+ \& B- wires)}$$

Figure 14—Field Wiring Distance Requirements for Solenoids

8.5 CASCADED WIRING CONNECTIONS

Only one wire is required for the cascaded connection as shown in Figure 13, the output channel “COMMON B” (PIN 2 of the output channel) of the first HSDM should be connected to the input channel “IN A” (PIN 1 of the Input Channel). There is no separate EOL resistor required for cascaded wiring, as the 10K EOL resistor is already part of output channel.



Improper wiring connections may result in the cascaded operation failing or could lead to damage to the circuitry.

8.6 PHYSICAL DISCONNECT SWITCH

In order to comply with NFPA 72 code requirements for releasing service fire alarm systems, a physical disconnect switch must be provided that opens the field wiring between the HSDM Output(s) and the solenoid(s). The switch must be installed with supervised wiring (see Figures 17 and 18)

The physical disconnect switch allows the overall system to be tested without actuating the fire suppression system. The physical disconnect switch also provides a means of completely isolating the solenoids from the HSDM outputs to reduce the likelihood of inadvertent discharge during maintenance activities. As part of the EQP system approval, physical disconnect switch

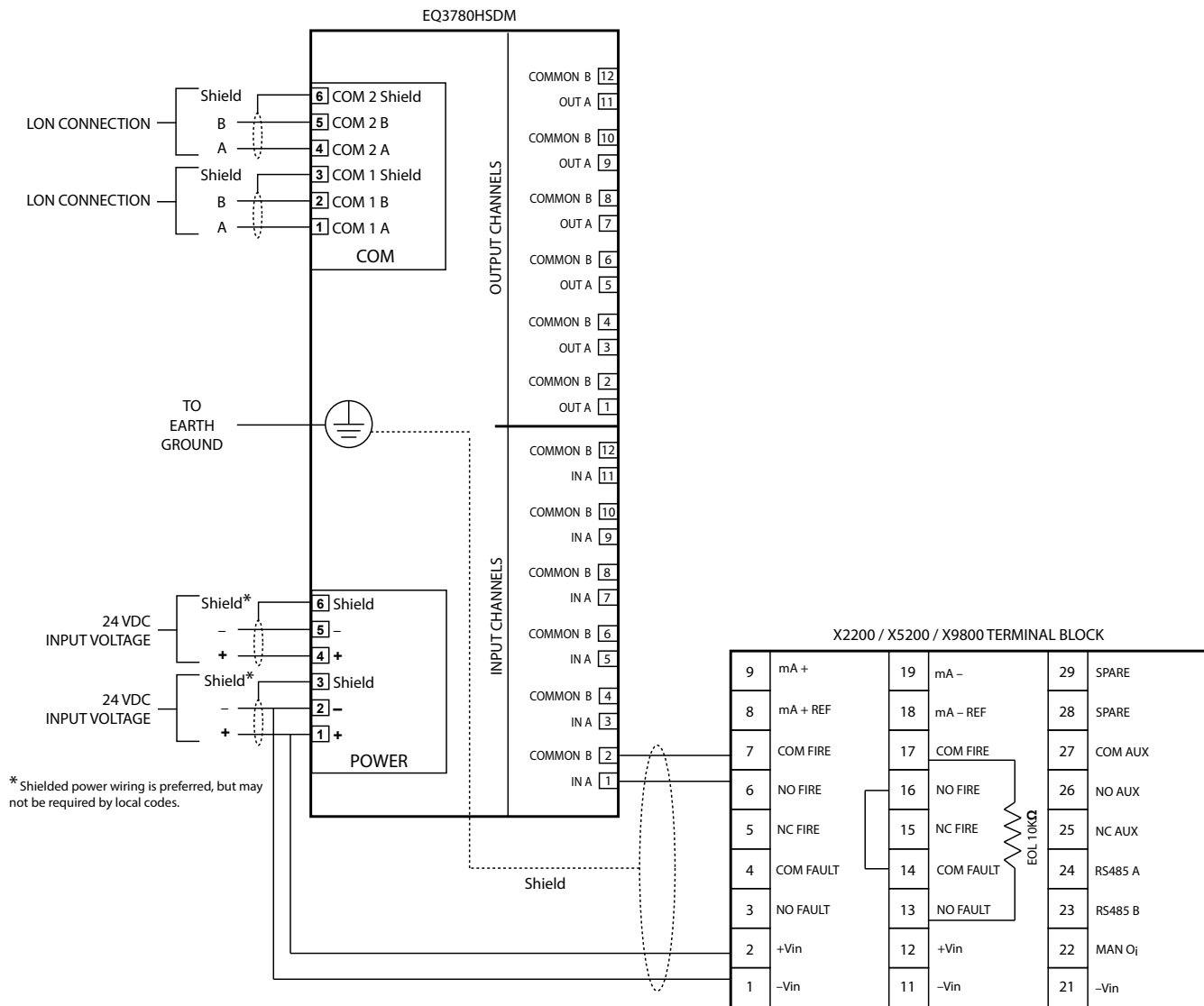

Figure 15—Typical Wiring for Single Flame Detector Wiring HSDM Supervising for Opens Only

(Det-Tronics part number 000128-191) is approved to be installed within the EQ3900G series of enclosures.

When the physical disconnect switch is operated, an open circuit fault will occur on the affected output channel of the HSDM. The supervisory fault will be annunciated by the EDIO EQP controller. The open circuit fault is expected and normal under these conditions. The use of a multi-pole switch can provide the physical disconnect function and a signal which can be connected into the EQP system through and Enhanced Discrete Input/Output (EDIO) module so that the use of the disconnect switch can be annunciated via EQP logic.

Additionally, a signal from the switch can be sent to another input module, such as an EDIO, to indicate that the switch has been used to isolate the solenoids

from the HSDM outputs. Please consult the factory for details.

HSDM Function during a Loss of Connection to the EQP Controller

Once the HSDM has been configured, if the communication connections between the HSDM and the EQP controller are ever lost, or the EQP controller is off-line, the HSDM will continue to monitor its input(s) and will activate its output(s) if necessary. Upon an activation of the input(s), the output(s) will activate according to how they have been configured, with any timed activation continuing until it is complete. During a loss of communication with the EQP controller, the LON isolation relays within the HSDM are utilized to attempt to maintain and/or reestablish communication with the EQP Controller.

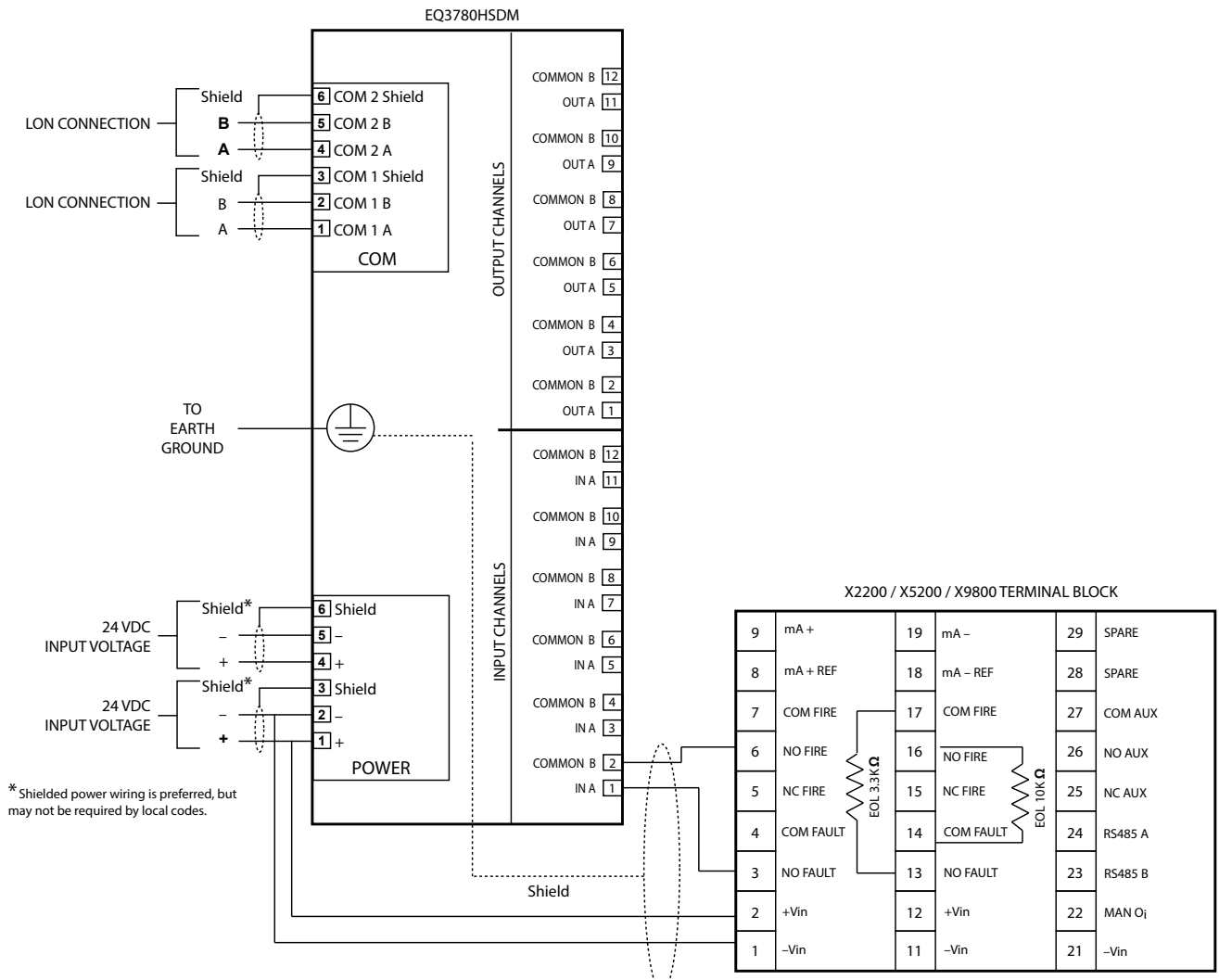

Figure 16—Typical Wiring for Single Flame Detector Wiring HSDM for Opens and Shorts

NOTE

Any static logic functions that are provided by the EQP controller will not be available if the EQP controller is off-line or if all LON communication is lost between the HSDM and the EQP controller.

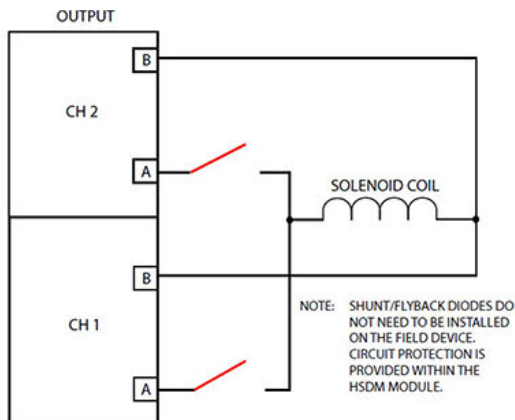

Figure 17—Supervised Output Configuration with Solenoid Disconnect Switch - Class A

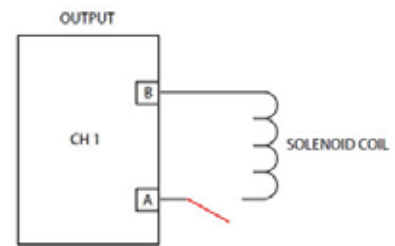
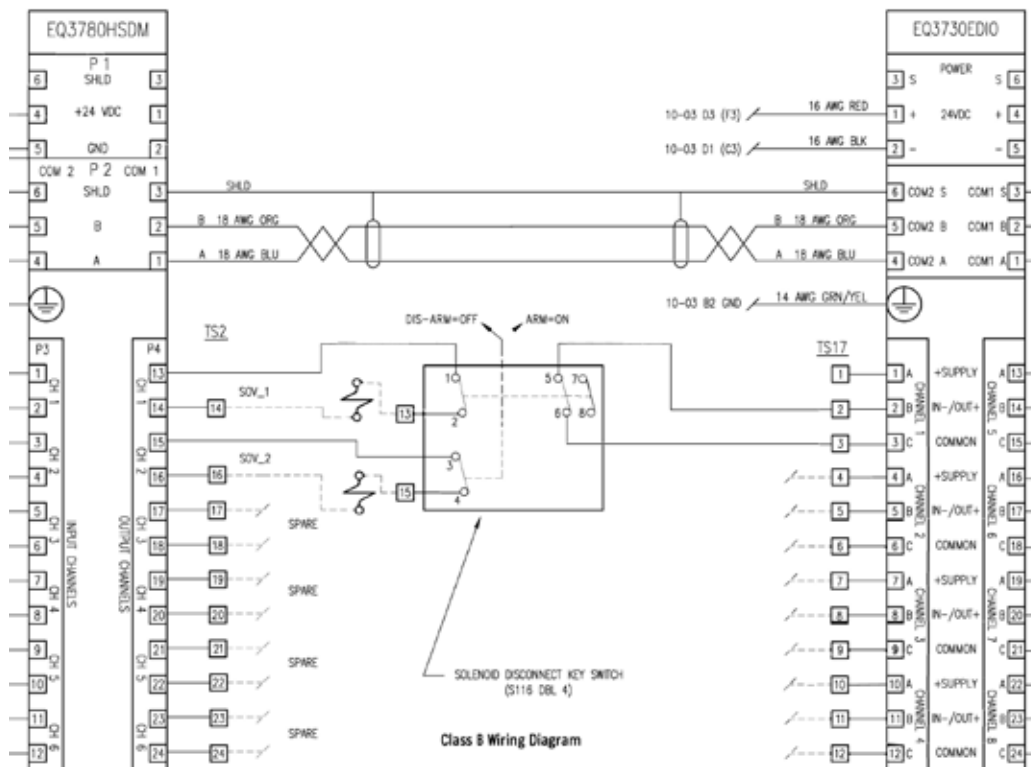
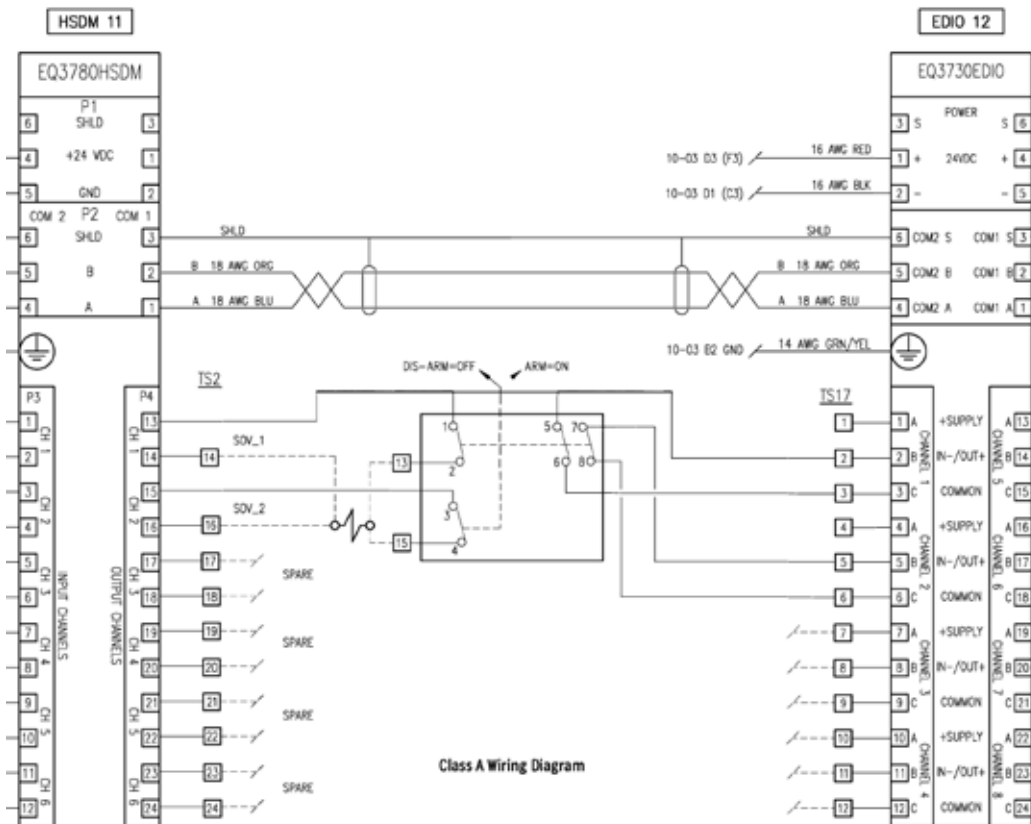

Figure 18—Supervised Output Configuration with Solenoid Disconnect Switch - Class B

Wiring Between EDIO and HSDM Modules



9.0 COMMISSIONING

Follow the steps below when commissioning the HSDM:

- A. Shut off water supply and lock out / tag out valves that supply deluge nozzles.
- B. Operate the Physical Disconnect switch to break the field wiring connections between the HSDM output(s) and the solenoid(s).
- C. Check power connections and LON connections for proper polarity and placement.
- D. Measure and confirm EOL resistance (if applicable) is present at each HSDM input
- E. Apply input voltage (24 Vdc nominal) at HSDM.
- F. HSDM will conduct a self-test. After the self-test is completed, ensure that the HSDM module level status LED is green and that LEDs for all configured input circuits are green. LEDs on all configured output circuits of the HSDM should be yellow.
- G. Operate the Physical Disconnect switch to reconnect the field wiring connections between the HSDM output(s) and the solenoid(s).
- H. The LEDs on all configured output circuits of the HSDM should turn green. The LED's on the output circuit channels that are not used will not be lit.
- I. Acknowledge and clear any fault conditions that are present on the EQP controller.
- J. Remove lock out / tag out from deluge supply valves and re-establish water supply.
- K. Bleed air out of hydraulic system.
- L. Perform a full system checkout to ensure response time requirements are met, test the entire system per cause and effect drawing, confirm all static logic functions.

10.0 SERVICING

Follow the steps below when servicing the HSDM:

- A. Shut off water supply and lock out / tag out valves that supply deluge nozzles.
- B. Operate the physical disconnect switch to break the field wiring connections between the HSDM output(s) and the solenoid(s).
- C. Ensure supervisory fault is displayed by the EQP controller for each channel of the HSDM that requires service. Each output channel of the HSDM that has been isolated should be identified by a yellow LED.
- D. Remove DC input power from the HSDM. Ensure that all LEDs are turned off.
- E. Service the product or circuits that are connected to it as necessary.
- F. When service is complete perform the commissioning steps that are outlined in section 9.0.

11.0 TROUBLESHOOTING

The HSDM contains many self-diagnosing features.

- A. Each input and output channel has LEDs that communicate status:
 - Green:** Normal Condition
 - Yellow:** Trouble / Fault Condition
 - Red:** Active Condition
- B. The cause for Trouble / Fault Conditions is transmitted via the LON to the EQP controller where the fault is displayed on the front panel. The Trouble/ Fault condition can further diagnosed by utilizing the point display for the HSDM within S3. Utilization of the point display is highly recommended to allow for a detailed examination of the cause of the fault condition.
- C. Common causes for a yellow input channel LED include disconnected field wiring between the detector and the HSDM, a missing or improperly sized EOL resistor, and a fault condition at the flame detector.
- D. Common causes for a yellow output channel LED include disconnected field wiring between the HSDM and the solenoid or an open solenoid coil.
- E. The yellow HSDM status LED blinks at 1 HZ if input voltage level is 20.8 Vdc or below, or if the HSDM is not configured. The status LED will be on steady if there is an internal start-up fault..

11.1 VOLTAGE FAULT CONDITIONS

The HSDM has two voltage fault conditions: Input Voltage Fault and Critical Voltage Fault.

Input Voltage Fault

An input voltage fault occurs on the HSDM when the input voltage is 20.8 Vdc or less. The point at which the fault occurs was selected to alert users that the voltage available at the output(s) may be insufficient to reliably activate a 24 Vdc solenoid. At this time, an input voltage fault is announced on the EQP controller.

Critical Voltage Fault

A critical voltage fault occurs when the input voltage is 17 Vdc or less. The point at which this fault occurs was selected to alert users that the HSDM can no longer reliably determine the state of an input channel. At this time, a critical fault is announced on the EQP controller.

12.0 ORDERING INFORMATION

When ordering, please specify the following:

EQ3780HSDM 12 Channel High Speed Deluge Module

Options:

Panel Mount
DIN Rail Mount
EOL Resistors

104106-001: EOL Resistor, 10K Ohms, 1%, wirewound.

Inline Resistors

1011118-009: Short Circuit Monitoring Resistor, 3.3K Ohms, 1%

For additional information or for assistance in designing a system to meet the needs of a specific application, please contact:

Detector Electronics Corporation
6901 West 110th Street
Minneapolis, Minnesota 55438 USA
(952) 941-5665 or (800) 765-FIRE
Customer Service: (952) 946-6491
Fax: (952) 829-8750
Web site: www.det-tronics.com
E-mail: det-tronics@det-tronics.com

13.0 DEVICE REPAIR AND RETURN

If your Det-Tronics equipment requires return, repair or replacement, we are ready to meet your needs. To accomplish this in the shortest amount of time, we need you to follow the steps outlined in our Return Materials Authorization (RMA) process. You can get information about the process from your authorized local sales representative or from our website, [www.det-tronics.com/support/returns & repairs/](http://www.det-tronics.com/support/returns%20&%20repairs/)

If it is determined that your material should be returned, Det-Tronics Technical Support ask you to complete an RMA form (online or downloadable). After receipt of this form, the team will issue you a unique RMA number. Include a copy of your RMA form inside the packaging. Please make certain you display the RMA number clearly on the outside of your packaging. Shipments received without this RMA number displayed will be refused.

Pack the unit properly. Always use sufficient packaging material. Where applicable, use an anti-static bag as protection from electrostatic discharge. Ship the material prepaid to the factory.

NOTE

Det-Tronics reserves the right to apply a service charge for repairing returned product damaged as a result of improper packaging.

NOTE

It is highly recommended that a complete spare be kept on hand for field replacement to ensure continuous protection.

EQ3780 HSDM MODEL MATRIX

MODEL	DESCRIPTION	
EQ3780	High Speed Deluge Module	
	TYPE	INSTALLATION OPTION
	P	Panel Mount
	D	DIN Rail Mount
	TYPE	APPROVALS
	T	SIL/FM/CSA/ATEX/IECEX



FlexSonic® Acoustic
Leak Detector



X3301 Multispectrum
IR Flame Detector



PointWatch Eclipse® IR
Combustible Gas Detector



FlexVu® Universal Display
with GT3000 Toxic Gas Detector



Eagle Quantum Premier®
Safety System



Det-Tronics manufacturing system is certified to ISO 9001—
the world's most recognized quality management standard.

© 2024 Det-Tronics. All Rights Reserved.

Corporate Office
6901 West 110th Street
Minneapolis, MN 55438 USA
www.det-tronics.com

Phone: +1 952.941.5665
Toll-free: +1 800.765.3473
Fax: 952.829.8750
det-tronics@carrier.com