

# Instructions

FlexSonic™ Acoustic Detector

AC100 Sensor

ATX10 Transmitter



# Table of Contents

OVERVIEW .....	3
FEATURES.....	3
BENEFITS .....	3
SPECIFICATIONS .....	4
DESCRIPTION.....	5
AC100 .....	5
ATX10 .....	6
OPERATION .....	8
Basic Mode .....	8
Profile Mode.....	9
Data Storage/Management.....	9
IMPORTANT SAFETY NOTES .....	13
INSTALLATION .....	13
Sensor Termination Box.....	13
Grease/Lubrication.....	14
Protection Against Moisture Damage.....	14
Foam Insert.....	14
Identification of Detector Mounting Locations .....	14
Detector Coverage.....	15
Power Supply Requirements .....	16
Wiring Cable Requirements .....	16
External Bonding.....	16
Shield Connections .....	16
Sensor Installation .....	16
Wiring Procedure .....	18
STARTUP .....	23
Basic Mode .....	23
Profile Mode.....	23
PreAlarm Configuration.....	25
Password Protection .....	26
GENERAL APPLICATION INFORMATION.....	26
Nuisance Sources.....	26
Friendly Leaks.....	26
MAINTENANCE.....	27
Routine Inspection .....	27
Cleaning.....	27
TROUBLESHOOTING .....	28
DEVICE REPAIR AND RETURN .....	29
ORDERING INFORMATION.....	29
Replacement Parts .....	29
Accessories.....	29
Assistance.....	29
APPENDIX A — FM APPROVAL DESCRIPTION .....	31
APPENDIX B — CSA CERTIFICATION DESCRIPTION.....	32
APPENDIX C — ATEX APPROVAL DESCRIPTION.....	33
APPENDIX D — IECEX APPROVAL DESCRIPTION .....	34
APPENDIX E — MARITIME APPROVAL.....	35
APPENDIX F — ADDITIONAL APPROVALS .....	36
APPENDIX G — APPROVED ADJOINING ASSEMBLIES.....	37

# FlexSonic™ Acoustic Detector

## AC100 Sensor

## ATX10 Transmitter

### OVERVIEW

The FlexSonic™ Acoustic Detector is designed to recognize the unique ultrasonic frequency content of events such as gas leaks. When a pressurized gas leak occurs, the frequency content of the sound being generated extends beyond the audible portion of the spectrum into the ultrasonic region (above 20 kHz). The intensity of the sound generated by a leak is determined by several factors including pressure, leak rate, gas viscosity, and distance from the leak source. Acoustic detection is less susceptible to environmental factors (such as high winds) that can degrade the ability of traditional sensing technology based on gas concentration to detect the presence of a leak. When combined with line of sight and/or point gas detectors, the additional layer of protection provided by the FlexSonic Acoustic Detector offers the ultimate solution for gas leak detection.

### FEATURES

- Long range response
- Nearly instantaneous response
- Gas leak detection without contact
- Adjustable detection range
- Superior false alarm discrimination
- Patented technology
- Suitable for harsh outdoor applications
- Stand alone capability from the ATX10 Transmitter
- 4-20 mA output combined with HART
- Globally approved explosion-proof 316 stainless steel housing
- Wide acoustic dynamic range
- Integrated Acoustic Integrity Check (AIC)
- Can detect small gas leaks at or below 6 bar (87 psi)
- Extensive data logging with removable storage



### BENEFITS

- Ideally suited for use in open or highly ventilated areas where traditional detectors are limited due to dilution
- Single detector can cover a large area
- Resistant to corrosion from most commonly encountered environmental contaminants
- Minimum maintenance required
- No routine calibration required
- Not affected by poisoning
- Functions with all gas types
- Fail-safe operation
- Certified SIL 2 Capable

## SPECIFICATIONS

### ATX10 and AC100

#### OPERATING VOLTAGE—

24 Vdc nominal; Operating range is 9 to 30 Vdc. Um=250 V (Intrinsic Safety Rating).

#### POWER CONSUMPTION—

AC100: 1.25 watts @ 9 Vdc  
1.25 watts @ 24 Vdc  
1.25 watts @ 30 Vdc.  
ATX10: 0.75 watts @ 9 Vdc  
1.25 watts @ 24 Vdc  
1.75 watts @ 30 Vdc.

#### TEMPERATURE RANGE—

Operating: -55°C to +75°C (-67°F to +167°F)  
Storage: -55°C to +85°C (-67°F to +185°F).

#### HUMIDITY—

5 to 95% RH, non-condensing (Det-Tronics verified).

#### INGRESS PROTECTION—

IP66, Det-Tronics tested per IEC 60529, NEMA/Type 4X.

#### CONDUIT ENTRIES—

3/4" NPT or M25.

#### ENCLOSURE MATERIAL—

316 stainless steel, electropolished.

#### SHIPPING WEIGHT—

AC100: 6.2 pounds (2.8 kilograms).  
ATX10: 11.5 pounds (5.2 kilograms).

#### DIMENSIONS—

See Figure 1.

#### WARM-UP—

Upon power-up, device performs self-test and initialization procedures, then automatically enters normal operating mode.

#### WARRANTY—

3 years.

## CERTIFICATION—

For complete approval details, refer to the appropriate Appendix:



Appendix A - FM  
Appendix B - CSA  
Appendix C - ATEX and UKCA  
Appendix D - IECEx  
Appendix E - Maritime  
Appendix F - Additional Approvals

SIL Approval - IEC 61508  
Certified SIL 2 Capable.

For specific information regarding SIL, refer to the Safety Reference Manual (form 95-8658) for details.

#### ELECTRO-MAGNETIC COMPATIBILITY—

EMC Directive 2014/30/EU

Emissions: EN61000-6.3  
EN61000-6.4

Immunity: EN61000-6.1  
EN61000-6.2

#### AC100 only

#### ACOUSTIC—

Dynamic Range: 40 to 139 dB

Ultrasonic Band: 24 individual bands over the ultrasonic frequency range (20 kHz to 80 kHz).

#### SELF-DIAGNOSTIC TEST (AIC)—

Automatic acoustic integrity check performed once every 10 (factory default) minutes.

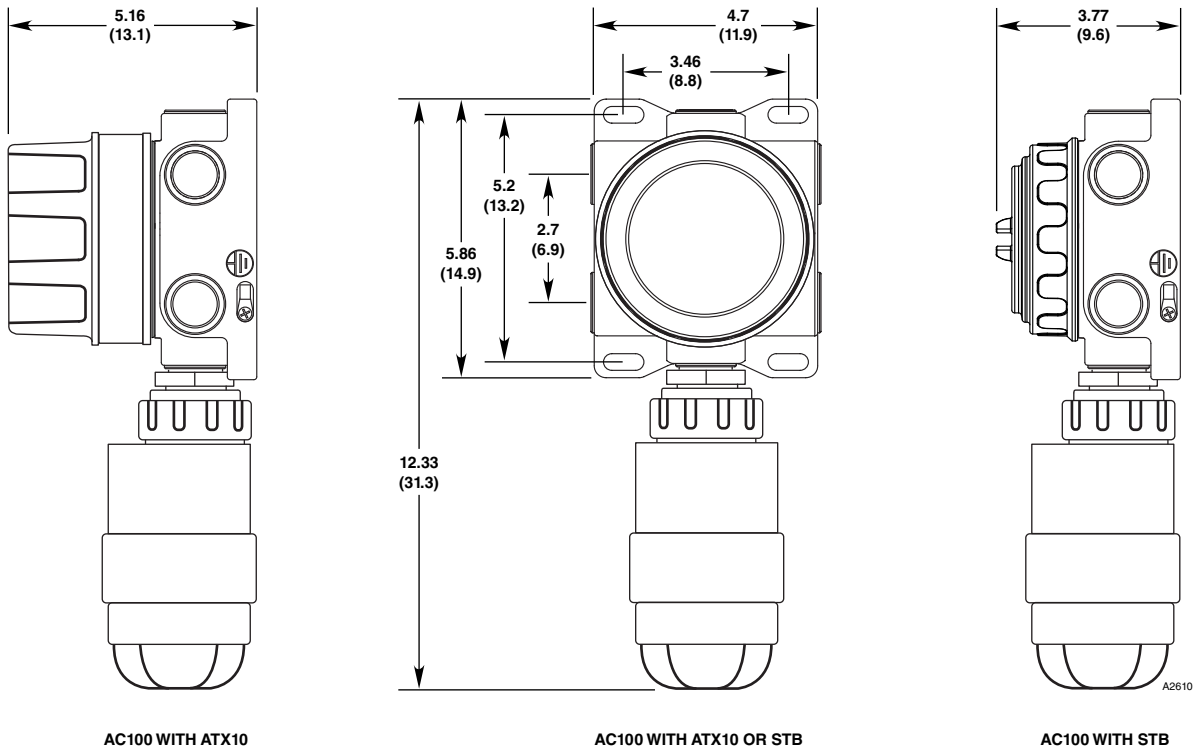

Figure 1—Dimensions of Acoustic Detector in Inches (Centimeters)

### ATX10 only

#### CURRENT OUTPUT—

4-20 mA with HART (non-isolated, sourcing\*)  
 20 mA indicates Alarm condition  
 16 mA indicates Pre-Alarm condition  
 4 mA indicates Normal condition  
 2 mA or less indicates a Fault condition.

\* Isolated or sinking operation requires the use of a FlexVu® Model UD10 Display.

#### MAXIMUM LOOP RESISTANCE—

300 ohms at 18 Vdc; 600 ohms at 24 Vdc.

#### WIRING TERMINALS—

Rated for 14 to 18 AWG (2.5 to 0.75 mm<sup>2</sup>) wire.

#### LED STATUS INDICATORS—

Power (Green)	Steady = Power on <Once per second = Learn Mode Twice per second = Manual AIC
Fault (Yellow)	Steady = Critical Fault <Once per second = Advisory Fault
Alarm (Red)	Steady = Alarm Twice per second = Pre-alarm

## DESCRIPTION

The FlexSonic Acoustic Detector is comprised of two main components: the AC100 Acoustic Sensor, and the ATX10 Acoustic Transmitter.

### AC100

The AC100 Acoustic Sensor detects events such as gas leaks by looking for changes in the spectrum of the received acoustic signal. To do this, the AC100 employs a high performance microphone and digital signal processing (DSP) technology to continuously monitor the acoustic signal.

The wide dynamic range and spectral resolution enable the sensor to provide both superior sensitivity and false alarm discrimination.

The AC100 Acoustic Sensor can be connected directly to the ATX10 Transmitter, or mounted remotely using an optional Sensor Termination Box (STB).

## ATX10

The main function of the ATX10 Transmitter is to evaluate the incoming acoustic power spectrum data from the AC100 Acoustic Sensor and make a determination of alarm condition. The transmitter communicates with the sensor via proprietary serial connection.

### Operating Power

The acoustic detector operates on 24 Vdc nominal (9 to 30 Vdc total range) system power via wired connection to terminal blocks in the transmitter junction box. The 24 Vdc is also passed through to the sensor unit for power.

### LEDs

The ATX10 includes three local LEDs on the faceplate to indicate Power (green), Fault (yellow), and Alarm (red) status.

LED Indication	Status
Steady Green	Power On
Slowly Flashing Green (<Once per Second)	Learn Function Active
Rapidly Flashing Green (Twice per Second)	Manual AIC in Progress
Steady Yellow	Critical Fault
Slowly Flashing Yellow (<Once per Second)	Advisory Fault
Steady Red	Alarm
Rapidly Flashing Red (Twice per Second)	Pre-alarm

See Figure 2 for LED locations.

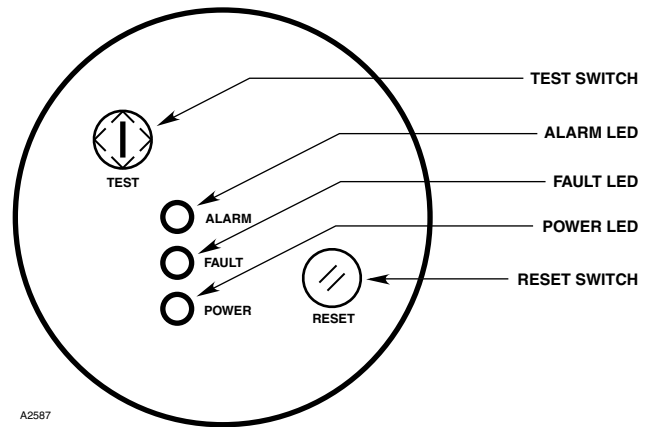

A2587

Figure 2—Magnetic Switches and LEDs on ATX10 Faceplate

### Magnetic Switches

The ATX10 includes two magnetic switches that support local initiation of an acoustic test, and clearing of latched alarms. See Figure 2 for magnetic switch locations.

### 4-20 mA Output

The safety function of the detector is communicated via the 4-20 mA HART output. Valid 4-20 mA outputs and their meanings are summarized below:

Output	Status
1 mA	Critical Fault
2 mA	Advisory Fault
4 mA	Normal
16 mA	Pre-Alarm
20 mA	Alarm

## Acoustic Integrity Check (AIC)

The AC100 Acoustic Sensor includes an integrated acoustic source capable of providing a variable frequency/amplitude output for system self test. Based on the proven innovation of Det-Tronics' flame detector optical integrity (o<sub>i</sub>)<sup>®</sup> model, the Acoustic Integrity Check (AIC) capability automatically or manually tests the sensor to verify proper operation and is user programmable. A fault condition (2 mA and yellow LED) is generated when reduced signal strength indicates a loss of detection range.

### Automatic AIC

The automatic AIC is a periodic, short duration test that does not activate alarms, LEDs or 4-20 mA signals, and is disabled if a pre-alarm or alarm condition exists.

Both the interval at which the AIC is performed, and the number of consecutive failures required to annunciate a fault are user selectable settings adjustable via HART. To maintain safe operation of the detector, the combination of AIC interval and successive failures before fault annunciation is limited so as not to allow the FlexSonic detector to exceed 60 minutes before indicating a failed AIC. See table below:

	<b>Automated AIC Interval (Minutes)</b>	<b>Maximum # of AIC Failures for Fault Annunciation</b>
<b>Adjustment Range</b>	1-60	1-60
<b>Increment</b>	1	1
<b>Default</b>	10	3

## Manual AIC

The Manual AIC is a system test that, when successful, results in a latched alarm indication and a 20 mA output. The RESET function is used to clear Manual AIC latched alarms.

### **NOTE**

***Ensure that system alarms are bypassed prior to initiating a manual AIC to prevent unwanted actuation.***

Manual AIC can be activated by placing the magnet at the 'TEST' icon on the ATX10 faceplate for at least 3 seconds. Activation of the Manual AIC results in a flashing green LED and an audible tone during the test (note that the test tone may not be detectable in loud environments or where hearing protection is worn).

An AIC failure results in a yellow LED and Fault indication (2 mA).

Following a Manual AIC, the acoustic detector can be reset by placing the magnet at the 'RESET' icon on the ATX10 faceplate for at least 3 seconds. The Reset switch resets any alarms or faults and places the detector back in the normal operating mode.

The Manual AIC test can also be initiated and reset via HART command.

## Event Logging

The ATX10 Transmitter generates an event log and saves the data to onboard flash memory where it can be retrieved via the HART interface. The following events are recorded to the ATX10 event log:

- Alarm
- Clear Alarm
- Pre-Alarm
- Clear Pre-Alarm
- Fault (sensor/transmitter)
- Clear Fault
- Automatic AIC Fail
- Power Up
- Configuration Change
- Memory Card Status Change (new, removed)
- Manual AIC

## Removable Memory

In addition to flash memory, the ATX10 includes a removable micro-SDHC memory card that stores both the event logs and recorded acoustic spectral data. The removable storage feature allows recorded spectral data files to be easily transferred from the detector and analyzed via specialized software.

The number of events and the duration of recorded acoustic data is limited only by the capacity of the memory card. The 4 GB memory card can store over 6 months of ambient acoustic input before overwriting old data.

The micro SD card can be accessed by removing the ATX10 Transmitter cover and unplugging the transmitter module from the mounting bracket.



**WARNING**  
*Power must be removed from the device prior to removing the cover in a hazardous location.*

## Communication (HART)

The ATX10 implements the HART 7.0 standard. Refer to FlexSonic HART manual 95-8698 for complete information regarding HART communication.

## OPERATION

The FlexSonic Acoustic Detector has two different modes of operation — Basic and Profile.

### BASIC MODE

The Basic Mode setting of the FlexSonic Acoustic Detector provides an adjustable, flat level alarm threshold when the background acoustic environment is largely unknown. The alarm threshold can be adjusted from 40 dB to 100 dB in 1 dB increments.

The alarm delay and recovery times are also user adjustable in Basic Mode. See Table 1 below for adjustment ranges and default settings for the Basic Mode alarm.

Table 1—Basic Mode Alarm Settings

Parameter	Level (dB)	Delay (Sec)	Recover (Sec)
Range	40 - 120	0 - 30	0 - 30
Increment	1	1	1
Default	59	5	1

An Autolevel function is also included in Basic Mode (not available in Profile mode). This function operates as a quick (10 second) intrinsic sound survey, analyzing the background acoustics and setting an alarm threshold level that is optimized to the background acoustic content present. It is important to note that any potential noise sources not present during the Autolevel analysis will not be accounted for in the alarm threshold setting and reduce the discrimination capability of the detector. For newly added, intermittent, or highly varying sources of background noise, it is recommended that the Learn Function in Profile Mode be used to optimize discrimination capability of the FlexSonic Acoustic Detector.

Table 2—Profile Mode Alarm Settings

Profile Type	Learn or Level						
Parameter	Level (dB)	Delay (Sec)	Recover (Sec)	Pre-Alarm On	Pre-Alarm Level	Sensitivity (dB)	Band Count
Range	40 - 120	0 - 30	0 - 30	Yes / No	0 - 99 dB	0 - 20	1 - 24
Increment	1	1	1	N/A	1 dB	1	1
Default	59	5	1	No	6 dB	4	14

**PROFILE MODE**

The Profile Mode of operation includes user adjustments for Pre-Alarm setting, and allows the use of either a level alarm threshold, or a dynamic alarm profile using the patented Learn Function. The Learn Function optimizes both detector sensitivity and discrimination by recording background environmental acoustic Sound Pressure Level (SPL) across a wide frequency range. The resulting ‘profile’ of the background SPL provides a unique acoustic fingerprint of that environment and is used as a dynamic alarm threshold. This feature of Profile mode allows the detector to ignore nuisance background sources without significantly impacting sensitivity or having to reposition the detector.

An important advantage is that the FlexSonic Acoustic Detector is immediately operational out-of-the-box while simultaneously performing an on-site sound survey with the Learn Function.

Table 2 details the user adjustments in Profile Mode.

**DATA STORAGE / MANAGEMENT**

**Flash Memory**

The ATX10 has onboard flash memory that is used as the primary location for storage of safety critical parameters. The ATX10 flash memory contains the following data files:

**Configuration Data** – The Configuration data includes all the settings that define the mode of operation of the ATX10.

**Saved Profiles** – In the Profile Mode of operation, the option to use the Learn Function is available. Up to 10 different acoustic profiles generated by the learn function can be saved to flash for use as the alarm threshold.

**Event Logs** – Specific alarms, faults, and configuration change events are logged with a time stamp to the onboard flash in the ATX10.

**SD Memory Module**

The ATX10 Memory Module is a removable storage feature implementing an extended temperature range micro SD card. The Memory Module provides storage capability for over 6 months of real time acoustic data as well as backup storage for the safety critical parameters maintained in onboard flash. The ATX10 Memory Module’s SD card is formatted as a standard FAT file system (typically FAT32), which allows the disk to be read by most PCs. The ATX10 Memory Module contains of the following data files:

**Real Time Log** – Acoustic spectral data and device status information are written to log files at a 1 second interval. When the Memory Module has reached capacity of real time log information, it will overwrite the older files.

**Configuration Data Copy**– When properly configured, the ATX10 will write a synchronized copy of the configuration data file from onboard flash to the Memory Module.

**Copy of Saved Profiles** – As with the Configuration data, the ATX10 will write a synchronized copy of the profile data to the SD Memory Module.

**SD Memory Module Operation**

At several times in the operation of the ATX10, a Memory Module Initialization will occur. This involves checking the presence and integrity of the Configuration and Profile files on the SD card.

The SD Card must meet the capacity and environmental ratings as specified by Det-tronics. The backup storage of data on the Memory Module also enables rapid configuration of replacement units, as well as SD card interchange via write protected HART commands:

**UPLOAD** – This command will leave the ATX10 flash memory unchanged, but synchronize the data by replacing the configuration and profile data files on the SD Memory Module. In other words, the data is uploaded from the ATX10 onboard flash to the SD Memory Module.

**DOWNLOAD** – This command modifies the ATX10 flash memory by replacing all configuration and profile data with the contents of the files on the SD Memory Module. In other words, the data is downloaded to the ATX10 onboard flash from the SD Memory Module.

Figure 3 is a flow chart showing how the Memory Module announcements arise, and the user intervention options that are available to get the Memory Module synchronized and operating normally.

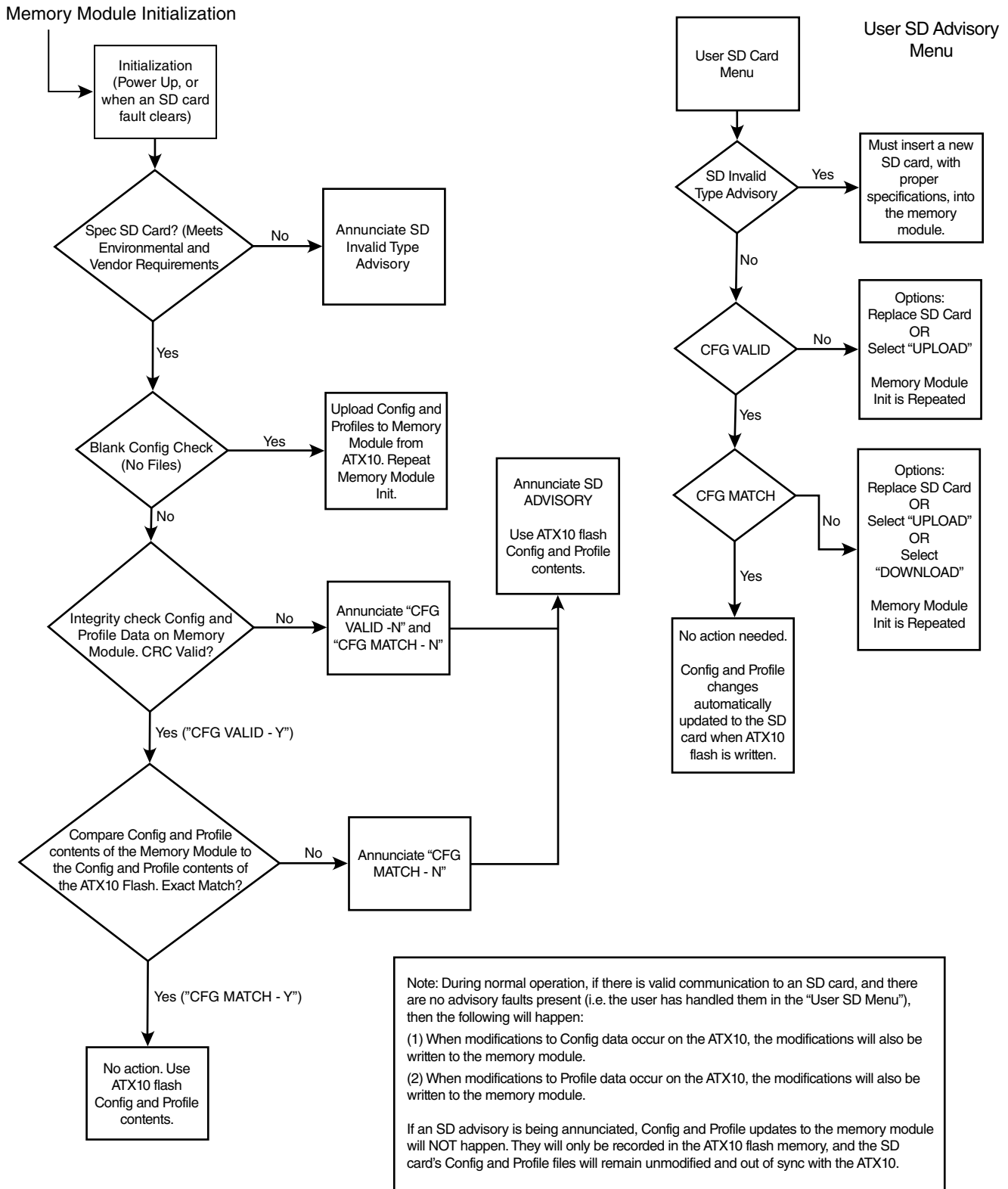

Figure 3—Memory Module Flow Chart

## SD Memory Module Removal / Replacement

The ATX10 Memory Module is a dual plug daughter board located on the back side of the ATX10 transmitter module. See Figure 4 for location. The SD memory card is attached to the memory module by a locking connector.

The memory module is designed to be easily removed from the transmitter module. To remove the memory module, simply grasp it with your fingers and pull it from the transmitter module circuit board (no tools required). The memory module is keyed to ensure correct orientation when replaced.

To remove the SD card from the memory module, follow the procedure shown in Figure 5.

### NOTE

**The SD card and memory module are not intended to be hot-swappable. Proper precautions must be observed when removing or replacing the memory module/SD card.**

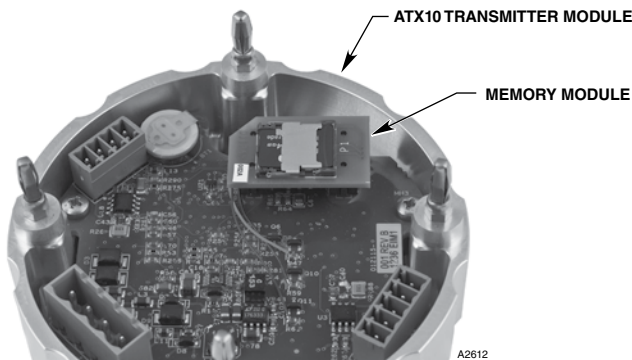

Figure 4—Location of Memory Module on Back Side of ATX10 Transmitter Module

Prior to removal of the Memory Module/SD card, it is recommended that the REMOVE option be selected via HART. This will disable communication to the SD card and annunciate an advisory fault. This is similar to selecting the option to “Safely Remove” a flash drive on a PC.

After re-inserting the Memory Module/SD card, the ENABLE option should be selected via HART. This should re-establish communication with the card after a memory module initialization.

The ATX10 Transmitter is intended to be used with the SD card in place, but will continue to perform its safety function should the memory be removed, damaged, or corrupted. An advisory fault (flashing yellow LED) will indicate conditions where the SD card is missing, non-operational, or of incorrect specification.

### NOTE

**The detector will continue to operate with an SD advisory fault present, however, the fault must be corrected in order to clear.**

### IMPORTANT

***If an SD Inop fault persists after normal startup, then remove and re-insert the SD card. When removing the SD card, ensure excessive force is not applied otherwise the card/connector assembly can be bent which can result in an “SD Card Inop” fault being annunciated due to insufficient contact between the SD card and the board.***

In the event that the SD card will not be used, it is possible to disable it entirely including fault annunciation. This is done with the DISABLE option selected via HART. This operation is permanent and the SD card will remain disabled, with no fault annunciation, even if power is cycled to the ATX10.

When the SD card is re-enabled with the ENABLE option selected via HART, there will be a momentary fault annunciation by a flashing yellow LED. This fault will clear itself after a short time, and is merely a communication check between the ATX10 and the SD card.

### NOTE

***It is NOT recommended to select the DISABLE option unless absolutely necessary as the benefits of real-time data logging will be lost.***

**STEP #1**

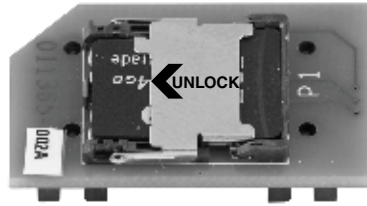

SLIDE THE LOCKING CONNECTOR BACK APPROXIMATELY 1/8 INCH (3 MM) TO UNLOCK THE SD CARD.

**STEP #2**



WHEN UNLOCKED, THE CARD/CONNECTOR ASSEMBLY AUTOMATICALLY OPENS TO THIS POSITION.

**STEP #3**

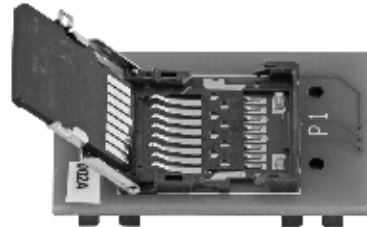

MOVE THE CARD/CONNECTOR ASSEMBLY TO THIS “FULL OPEN” POSITION. BEFORE REMOVING THE CARD, NOTE ITS POSITION. THE CARD MUST BE RETURNED TO THIS EXACT POSITION LATER IN ORDER TO CLOSE THE CONNECTOR.

**STEP #4**

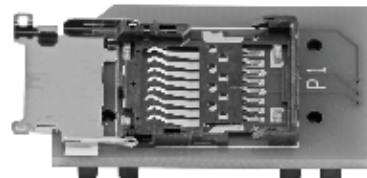

REMOVE THE SD CARD. WITH THE CARD REMOVED, THE CONNECTOR LIES FLAT AGAINST THE CIRCUIT BOARD.

**STEP #5**

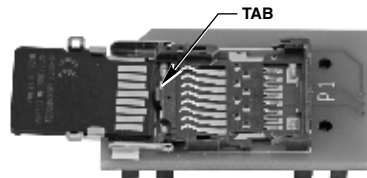

TO RETURN THE SD CARD, PLACE THE CARD IN THE CONNECTOR AS SHOWN. NOTE ITS POSITION AGAINST THE TAB. REPEAT THE FIRST THREE STEPS IN REVERSE ORDER AS FOLLOWS: RAISE THE CARD/CONNECTOR ASSEMBLY WHILE GENTLY PRESSING THE CARD AGAINST THE TAB. WHEN THE CARD CLEARS THE TAB (SEE PHOTO #3), THE CONNECTOR CAN BE CLOSED AND LOCKED.

Figure 5—Procedure for Removal and Re-Installation of SD Memory Card

## IMPORTANT SAFETY NOTES

### CAUTION

The wiring procedures in this manual are intended to ensure proper functioning of the device under normal conditions. However, because of the many variations in wiring codes and regulations, total compliance to these ordinances cannot be guaranteed. Be certain that all wiring complies with the NEC as well as all local codes. If in doubt, consult the authority having jurisdiction before wiring the system. Installation must be done by a properly trained person.

### CAUTION

This product has been tested and approved for use in hazardous areas. However, it must be properly installed and used only under the conditions specified within this manual and the specific approval certificates. Any device modification, improper installation, or use in a faulty or incomplete configuration will render warranty and product certifications invalid.

### CAUTION

The device contains no user serviceable components. Service or repair should never be attempted by the user. Device repair should be performed only by the manufacturer.

### LIABILITIES

The manufacturer's warranty for this product is void, and all liability for proper function of the detector is irrevocably transferred to the owner or operator in the event that the device is serviced or repaired by personnel not employed or authorized by Detector Electronics Corporation, or if the device is used in a manner not conforming to its intended use.

### CAUTION

Observe precautions for handling electrostatic sensitive devices.

### CAUTION

Unused conduit entries must be closed with suitably certified flameproof blanking elements upon installation.

## INSTALLATION

### NOTE

Detector housings must be electrically connected to earth ground. A dedicated earth ground terminal is provided.

### NOTE

The AC100 has an Intrinsic Safety (IS) Barrier. Proper NEC/CEC IS grounding must be ensured.

### NOTE

The detector must always be installed per local installation codes.

### NOTE

Use of a threaded adapter for connecting the AC100 to the STB or ATX10 is prohibited.

### NOTE

The ATX10 transmitter module is shipped with the SD card installed in the memory module. A piece of tape has been installed to secure the card in place and prevent it from becoming dislodged during shipping. See Figure 6. The shipping tape should be removed prior to commissioning the acoustic detector.

## SENSOR TERMINATION BOX

A Det-Tronics sensor termination box (Model STB) is required for installations where the AC100 is not connected directly to the ATX10 transmitter housing. When installing the AC100 remotely from the transmitter, shielded cable using twisted pair wires for signal is required to prevent possible nuisance EMI/RFI. The maximum cable length between the AC100 and the ATX10 is 500 ft.

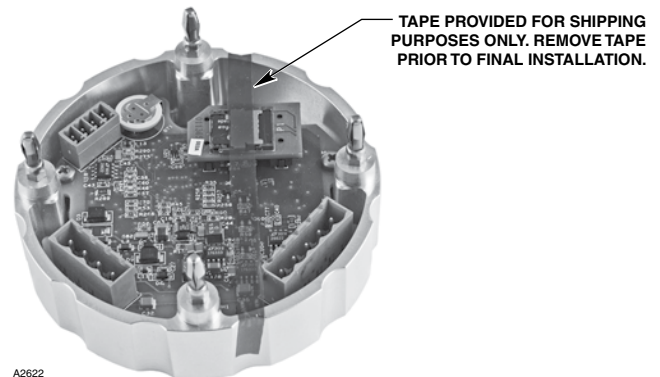

Figure 6—Remove Shipping Tape from Transmitter Module

## GREASE/LUBRICATION

To ease installation and future removal, ensure that all junction box covers and sensor threads are properly lubricated. If the need arises for additional lubrication, use either Lubriplate grease (see Ordering Information for part number) or Teflon tape. Avoid the use of silicone grease.

## PROTECTION AGAINST MOISTURE DAMAGE

It is important to take proper precautions during installation to ensure that moisture will not come in contact with the electrical connections of the system. The integrity of the system regarding moisture protection must be maintained for proper operation and is the responsibility of the installer.

If conduit is used, the use of proper conduit installation techniques, breathers, glands, and seals is required to prevent water ingress and/or maintain the explosion-proof rating.

Conduit drains must be installed at water collection points to automatically drain accumulated moisture. Conduit breathers should be installed at upper locations to provide ventilation and allow water vapor to escape. At least one breather should be used with each drain.

Conduit raceways should be inclined so that water will flow to low points for drainage and will not collect inside enclosures or on conduit seals. If this is not possible, install conduit drains above the seals to prevent the collection of water or install a drain loop below the detector with a conduit drain at the lowest point of the loop.

Conduit seals are required for compliance with NEC/CEC explosion-proof installation requirements and to prevent water ingress in outdoor applications. Seal all conduits within 18 inches of the device. Units with M25 threads must use an IP66 rated washer or an IP66 rated cable gland with O-ring to prevent water ingress.

## FOAM INSERT

A foam insert (optional) is recommended in applications where wind driven sand or other high velocity particulates can penetrate the sensor's protective cover and cause damage to the microphone and/or AIC sound emitter. The foam insert should not be used in very wet environments.

To install the insert, ensure that the device is powered off, then remove the protective cover from the sensor housing by turning counterclockwise (no tools required). Carefully press the insert inside the cover (See Figure 7), then re-install the cover on the sensor. Refer to the Maintenance section of this manual for additional information regarding the insert.

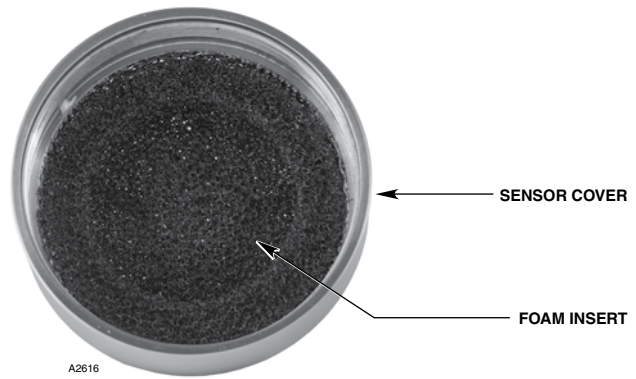

Figure 7—Foam Insert Installed Inside Sensor Cover

## IDENTIFICATION OF DETECTOR MOUNTING LOCATIONS

Identification of the most likely leak sources is typically the first step in determining optimal locations for acoustic detection.

It is not required to aim the FlexSonic detector toward a potential leak source. The preferred orientation for the AC100 Acoustic Sensor is positioned vertically downwards.

It is recommended that the acoustic detector be mounted at or above the level at which the potential leak is likely to occur.

If the installation requires mounting the detector close to ground level, note that the effective detection range may be reduced due to the potential effects of ground absorption and reflection.

The most effective number and placement of detectors varies depending on the conditions on site. The individual designing the installation must often rely on experience and sound judgment to determine the detector quantity and best locations to adequately protect the area. Note that it is typically advantageous to locate detectors where they are accessible for maintenance.

To facilitate improved viewing with various installation orientations, the ATX10 faceplate can be rotated in 90 degree increments. Access the ATX10 faceplate by unscrewing the cover and pulling the transmitter module from the mounting posts that secure it to the junction box, then reposition it as desired. Note that the module is held in place by a compression fitting – no screws are involved.

## DETECTION COVERAGE

The FlexSonic Acoustic Detector is an omni-directional acoustic analyzer that can recognize the unique frequency content of events such as gas leaks. The high-frequency sound energy generated by pressurized gas escaping is dependent upon several factors such as gas pressure, geometry of the leak opening, gas viscosity, as well as environmental conditions such as temperature and humidity.

It is recommended that the detector be mounted above the potential leak sources in the coverage area to minimize attenuation of acoustic signal from the detector housing itself. Also, care should be taken to eliminate acoustic blind spots caused by equipment, scaffolding, etc. that lie between the detector and potential leak sources.

Background noise can also diminish the effective coverage area, however, the patented Learn function allows the FlexSonic Acoustic Detector to ignore many sources of high frequency sound energy without negatively impacting detection range (e.g. moving the detector, or raising the alarm threshold level). For best performance, it is recommended that the acoustic environment where the detector is to be placed be captured with either the onboard learn function or data logging capabilities of the FlexSonic Acoustic Detector. The acoustic profile generated can be used to very accurately display the exact content/sources of background noise, and optimize the alarm threshold setting. Refer to the Data Management and Profile Mode sections of this manual for additional information on alarm settings.

Detection range will vary depending upon the leak rate, environment, and installation factors described. Reference detection ranges for the FlexSonic Acoustic Detector are provided below (detector mounted 2 meters above ground pointing vertically downwards, and low ambient background noise > 20 kHz):

### Leak Source:

Leak Rate:	0.004 Kg/Sec
Gas Type:	Compressed Air
Gas Pressure:	6 Bar (87 psi)
Leak Orifice:	2 mm round
Orientation:	Straight up

Detection coverage is specified as a radius with the leak source at or below detector level, and unobstructed by infrastructure.

Basic Mode, 50 dB setting =  
12 meter radius (40 feet)

Profile Mode (4 dB above background) =  
20 meter radius (66 feet)

For information regarding installation of the FlexSonic Acoustic Detector in a specific application, please contact the Det-Tronics factory.

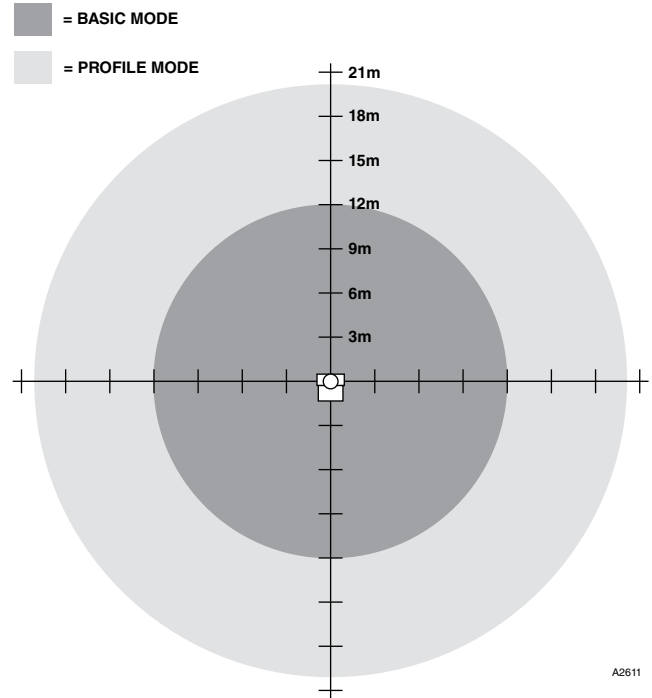

Coverage Range of FlexSonic Acoustic Detector (Low Level Leak)

## POWER SUPPLY REQUIREMENTS

Calculate the total gas detection system power consumption rate in watts from cold start-up. Select a power supply with adequate capability for the calculated load. Ensure that the selected power supply provides sufficient regulated and filtered output power for the entire system. If a back-up power system is required, a float-type battery charging system is recommended. If an existing source of power is being used, verify that system requirements are met.

### NOTE

***The power supply must meet the noise requirements for HART systems. If noise or ripple on the main power source could interfere with the HART function, an isolated power source is recommended. (For detailed information regarding power supply specifications, refer to the HART Communication Foundation's document "FSK Physical Layer Specification" HCF\_SPEC-54.)***

## WIRING CABLE REQUIREMENTS

Always use proper temperature rated cabling type and diameter for input power as well as output signal wiring. 14 to 18 AWG shielded stranded copper wire is recommended.

The field wiring terminal connections are certified for a single wire in size from 0.2 to 2.5 mm<sup>2</sup> (or two conductors with same cross section 0.2 to 0.75 mm<sup>2</sup>). The screws must be tightened down with a torque 0.4 to 0.5 Nm. The metal housing must be electrically connected to earth ground.

A minimum of 9 Vdc must be present at the ATX10 to ensure proper operation. The maximum cable length from power source to ATX10 is 2000 feet. When the AC100 Sensor is mounted remotely using an STB termination box, maximum cable length from ATX10 to AC100 is 500 feet.

### NOTE

***The AC100 has an Intrinsic Safety (IS) Barrier. Proper NEC/CEC IS grounding must be ensured.***

### NOTE

***In applications where the wiring is installed in conduit, dedicated conduit is recommended. Avoid low frequency, high voltage, and non-signaling conductors to prevent nuisance EMI problems.***

## CAUTION

***The use of proper conduit installation techniques, breathers, glands, and seals is required to prevent water ingress and/or maintain the explosion-proof rating.***

## EXTERNAL BONDING (AC100 and ATX10)

Per ATEX/IECEx requirements, 4 mm<sup>2</sup> wire shall be attached to external ground connection.

## SHIELD CONNECTIONS

The ATX10 provides terminals for proper grounding of wiring cable shields. These shield terminals are not connected internally, but are connected to ground through capacitors. The capacitors ensure an RF ground, while preventing 50/60 Hz ground loops.

Ground all shields as shown in the wiring examples throughout this manual.

### IMPORTANT

***For proper grounding, all junction boxes / metal enclosures must be connected to earth ground.***

The following are required for installations requiring CE Mark compliance:

- For shielded cable installed in conduit, attach the wire shields to the "shield" connections on the terminal blocks, or to earth ground on the case.
- For installations without conduit, use double shielded cable. Terminate the outer shield to earth ground on the case. Terminate the inner shield to the "shield" connection on the terminal blocks.

## SENSOR INSTALLATION

### 3/4" NPT Models

3/4" NPT models have tapered threads and a connector assembly. Install the sensor as follows:

1. Screw the sensor into the appropriate entry on the termination box. Ensure a **minimum** of 5 fully engaged threads. Use of Teflon tape on NPT threads is recommended to prevent thread damage.
2. When the sensor gets tight, note the position of the set screw on the sensor housing. It should be oriented away from the mounting surface to ensure adequate clearance between the sensor and mounting surface. See Figure 8.

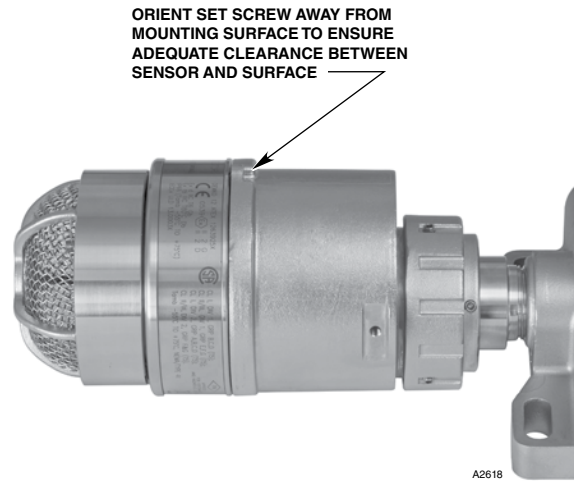

Figure 8—AC100 Connected to Termination Box (M25 Model Shown)

### M25 Models

M25 models have straight threads and a removable connector assembly with lock nut. Install the sensor as follows:

1. Remove the connector assembly from the AC100 Sensor. See Figure 9.
2. Screw the lock nut as far back as it will go (finger tight only), then screw the connector assembly into the appropriate entry on the termination box. A light coating of grease on the threads is recommended.
3. Screw the assembly into the termination box as far as it will go and tighten with a 35mm socket wrench.
4. Tighten the lock nut against the termination box. See Figure 10.
5. Insert the sensor wires through the connector assembly into the termination box, then secure the sensor to the termination box by tightening the ring on the connector assembly. Prior to tightening the ring, orient the sensor with the set screw away from the detector mounting surface to ensure adequate clearance between the sensor and mounting surface. See Figure 8.
6. Tighten the connector ring, then install set screws to prevent movement.

#### NOTE

***There are a total of six set screw holes on the connector ring, three on the lower level and three on the upper level. Install at least one set screw on each level. See Figure 11.***

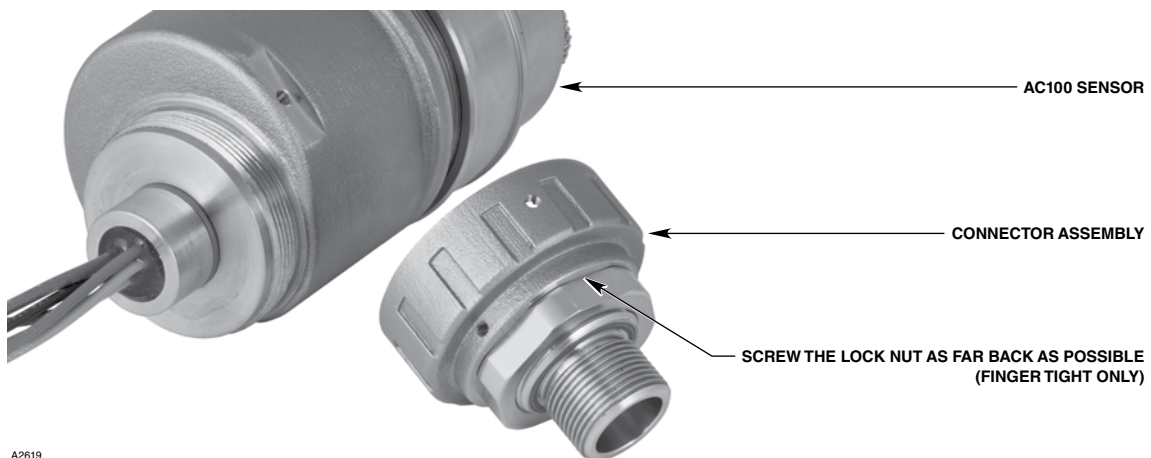

Figure 9—AC100 with Connector Assembly Removed

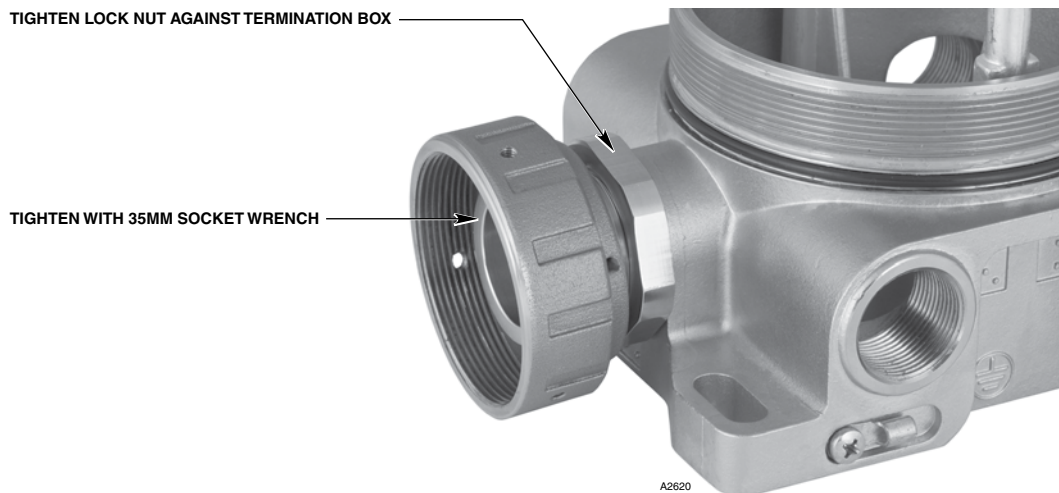

Figure 10—Connector Assembly Attached to Termination Box

## WIRING PROCEDURE

Ensure that all cables are terminated properly. Conductor insulation should be stripped off with a bare conductor length of 0.2 inch (5 mm) minimum and 0.7 inch (18 mm) maximum. Ensure that cable shield is properly terminated and that bare shield wire is not allowed to accidentally contact the metal housing or any other wire.

### IMPORTANT

*The AC100 GND wire (green, 16 AWG, 1.31 mm<sup>2</sup>) must be properly grounded inside the STB or ATX10 to maintain proper Intrinsic Safety connections. A lug is provided and must be properly crimped to the wire and secured with the provided screw and washer at the location marked by the GND symbol. The AC100 and the adjoining STB/ATX10 are also provided with an external GND connection (lug screw and washer provided) that must be bonded to a suitable earth GND connection. In addition, the power supply GND must be terminated at the STB/ATX10 to ensure 1 ohm or less resistance.*

Figure 12 shows the wiring terminals on the ATX10 Transmitter.

Figure 13 shows an AC100 wired directly to an ATX10 Transmitter.

Figure 14 shows an AC100 connected to an STB termination box and wired to an ATX10 Transmitter.

Figure 15 shows power and signal wiring for an ATX100 wired to a PLC.

Figure 16 shows an ATX10 with AC100 wired to a FlexVu UD10 Universal Display. Refer to the UD30 Instruction Manual (95-8764) for wiring the AC100/ATX10 to the FlexVu UD30 Universal Display.

See Figure 17 for benchtop test wiring.

### NOTE

*For proper HART communication, a signal loop resistance of 250 ohms must be present at the 4-20 mA output terminals.*

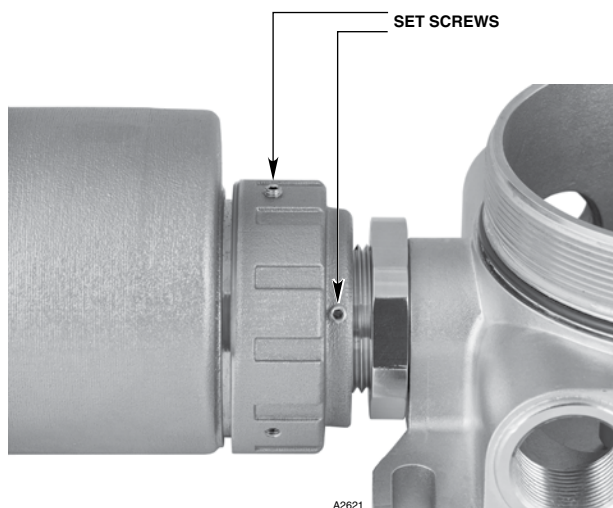

Figure 11—Set Screw Locations on Connector Ring

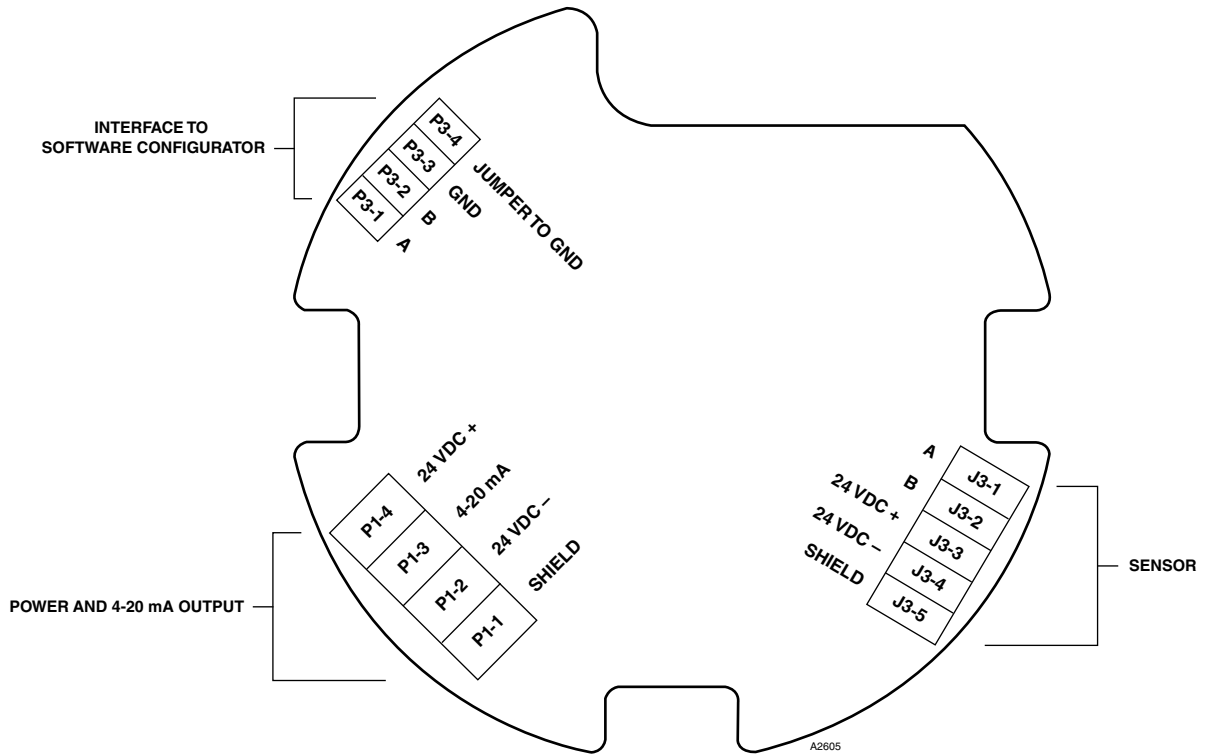

Figure 12—ATX10 Transmitter Wiring Terminals

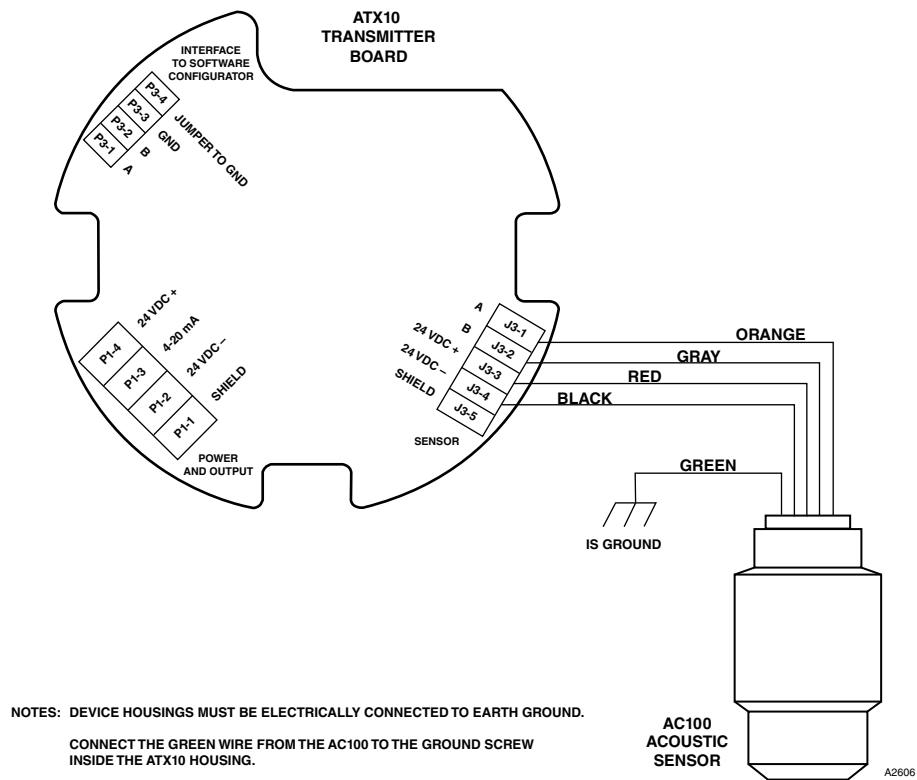

Figure 13—AC100 Acoustic Sensor Wired to ATX10 Transmitter

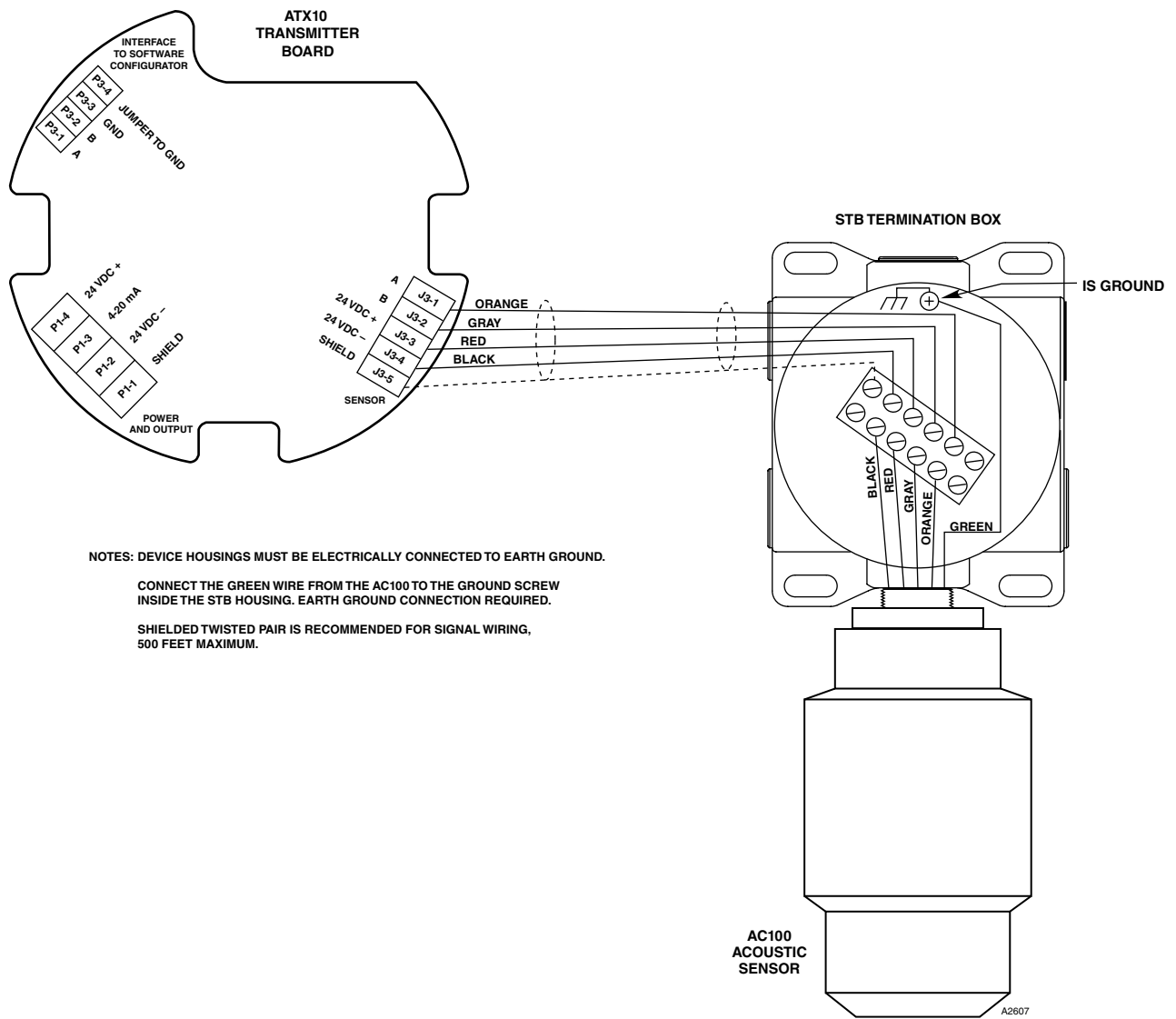

Figure 14—AC100 Acoustic Sensor Connected to STB and Wired to ATX10 Transmitter

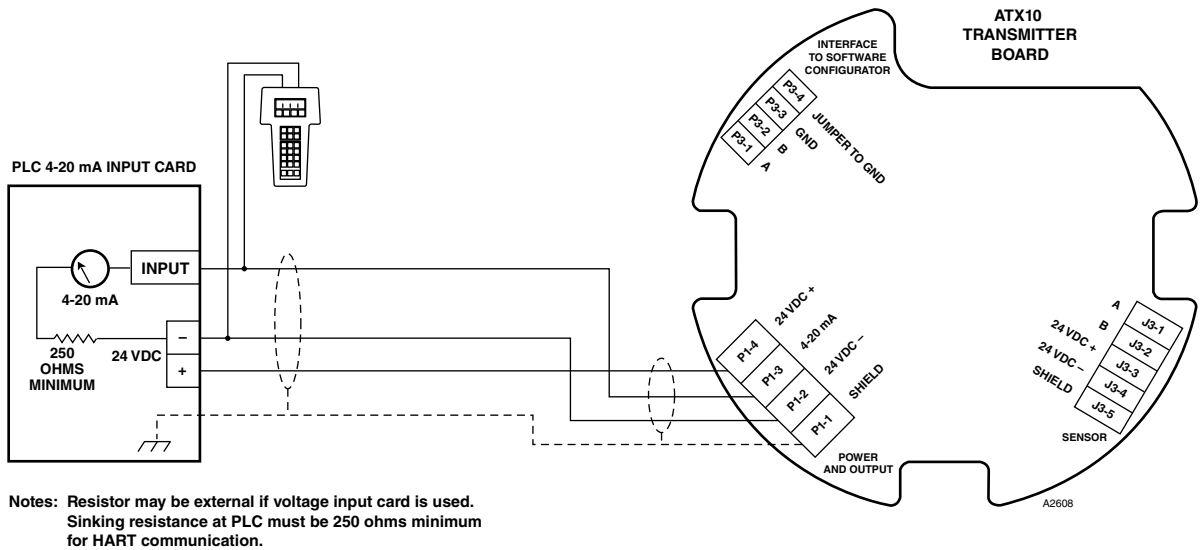

Figure 15—ATX10 Transmitter Wired to PLC

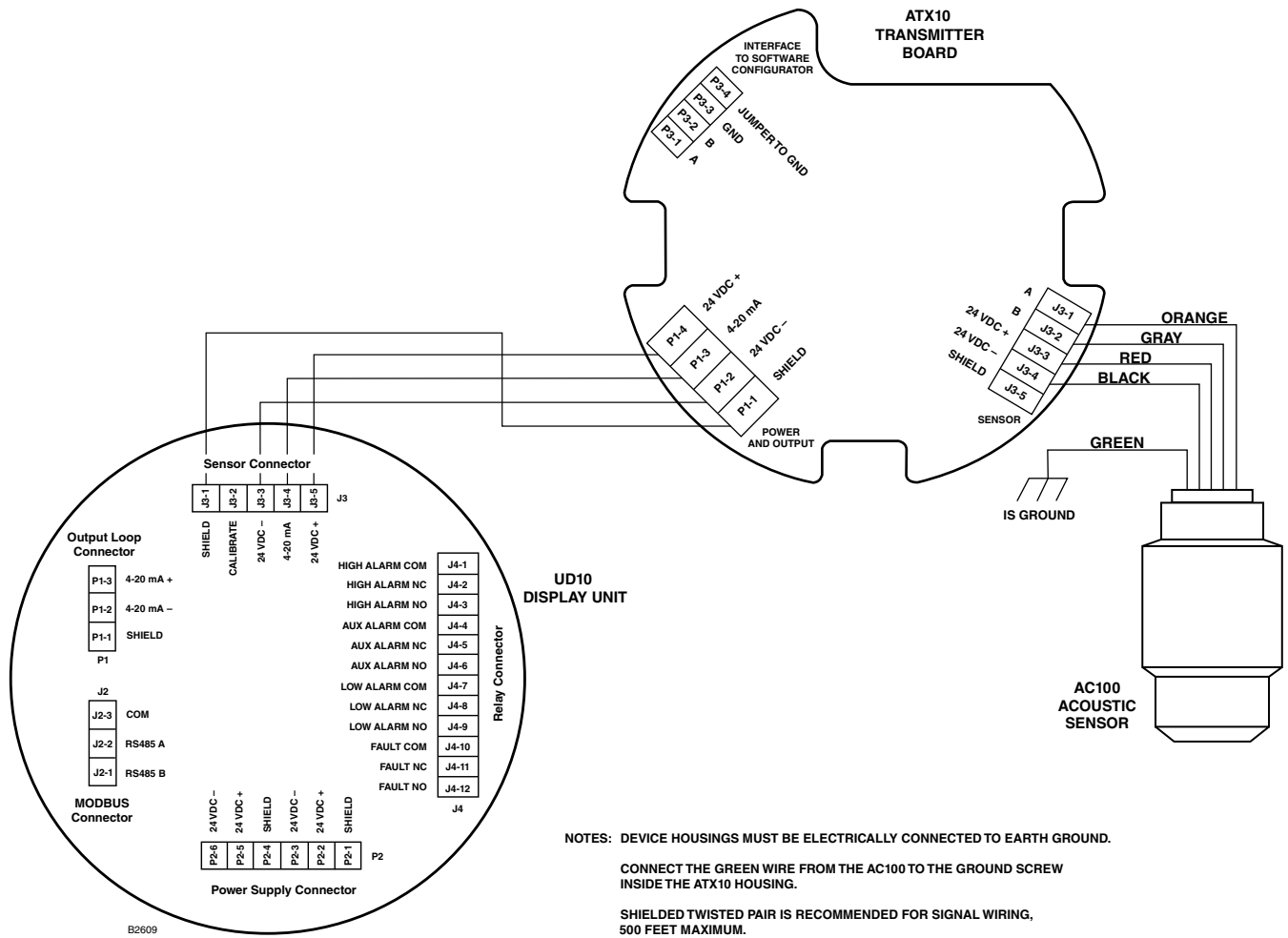

Figure 16—ATX10 Transmitter with AC100 Wired to FlexVu UD10 Display

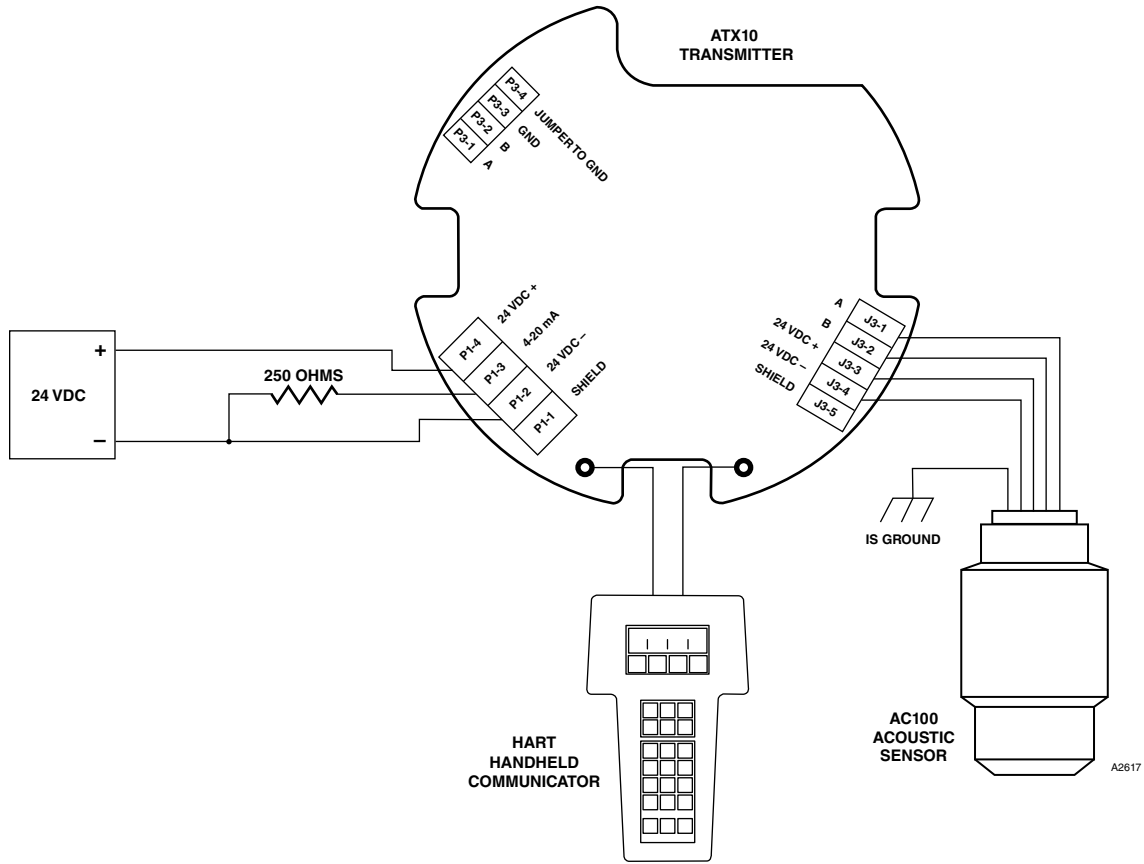

Figure 17—Wiring the Acoustic Detector for Benchtop Testing/Programming Using HART Protocol

# STARTUP

## NOTE

Upon powering up the Flexsonic, the ATX10 will announce a fault. This is due to the ATX10 trying to establish communication with the SD card. This action will cause the fault LED to blink for a short period of time before automatically clearing itself.

The fault will be logged as an SD inop event. However, this is merely a functionality check.

The following section describes configuration of the acoustic detector (using a HART handheld device) for the following modes of operation:

- **Basic**
- **Profile - Level / Learn**

The ATX10 is factory programmed to run in **Basic** operating mode. This mode of operation uses the simplest setup process, but offers the fewest options for adjusting sensitivity.

**Profile** mode is an alternate option that allows access to additional configuration parameters, as well as the ability to “Learn” background profiles.

## BASIC MODE

**Basic** mode uses a simple alarm detection technique. The detector searches the ultrasonic spectrum for bands that exceed a fixed threshold. When a sufficient number of these bands exceeds the pre-set level, an alarm condition is detected (adjustment range = 40-120 dB, default = 59 dB). If the alarm condition continues for a fixed period of time, an alarm output is generated (adjustment range = 0-30 seconds, default = 5 seconds). The fixed threshold level and the fixed time period are field selectable, and are the only variables that need to be considered in **Basic** mode. Use the following procedure to configure the detector for **Basic** operating mode.

1. Navigate the HART menu as follows:  
DEVICE MENU > DEVICE SETUP > ALARM SETUP > MODE > BASIC.

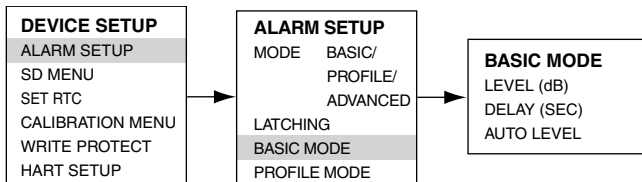

2. In the BASIC MODE menu, set the LEVEL (dB): This should be set to a numeric value between 40 and 120 (factory default is 59). This represents the threshold at which a leak will be detected and an alarm declared. Lower numbers represent greater sensitivity and higher numbers will result in less sensitivity to alarm. This value can be set manually, or by using the AUTO LEVEL function.

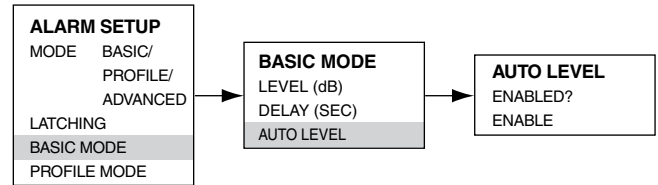

3. AUTO LEVEL can be set as follows:  
Enable AUTO LEVEL via the ENABLE command in the AUTO LEVEL submenu. The detector will automatically select a new LEVEL (dB) setting based on the background noise picked up during a 10 second (not field adjustable) interval.
4. Set the DELAY (SEC): This delay represents the time that an alarm condition must be held in order to announce an alarm (adjustment range = 0-30 seconds, default = 5 seconds). It is normally not necessary to change this value. However, it can be useful to increase the delay if there are false alarms due to momentary events.

## PROFILE MODE

In the **Profile** operating mode, the detector still uses the same alarm detection techniques. However, several additional options and capabilities are offered. Use the following procedure to configure the detector for **Profile** operating mode.

1. Navigate the HART menu as follows:  
DEVICE MENU > DEVICE SETUP > ALARM SETUP > MODE > PROFILE.

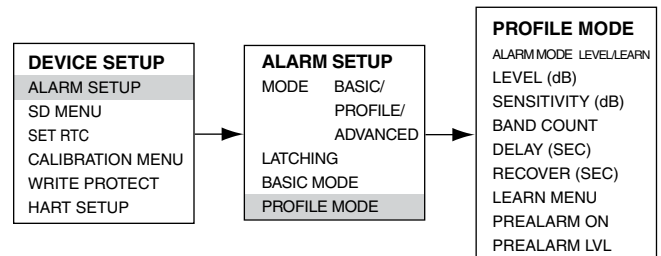

2. In the PROFILE MODE menu, select ALARM MODE, and then either LEVEL or LEARN (the following sections describe the differences between LEVEL and LEARN).

## Profile-Level

The **Profile-Level** mode uses the same fixed threshold concept as **Basic** mode. There is a LEVEL (dB) setting, but no AUTO LEVEL function. The benefit of using **Profile-Level** is that some additional settings are available for increased flexibility.

In some applications the use of the factory default settings in the **Profile-Level** mode may be adequate, however, it is possible to customize the acoustic detection using the additional settings. The following additional settings are available in **Profile-Level**:

**BAND COUNT** – In **Basic** mode, the number of frequency bands that exceed the LEVEL (dB) threshold are counted. An alarm condition exists when this count exceeds 14 bands. This number is fixed in **Basic** mode. In **Profile-Level** mode it can be adjusted (adjustment range = 1-24, default = 14). Lower numbers tend to make the detector more sensitive to narrow band signals, including pure tones or other ultrasonic emitting devices. Higher numbers tend to decrease the sensitivity of the detector and require broadband ultrasonic sound to exceed the LEVEL(dB) threshold in more bands.

**RECOVER (SEC)** – This setting specifies the time (in seconds) that elapses from the moment the alarm criteria are no longer met until the alarm is cleared.

## Profile-Learn

The **Profile-Learn** mode uses variable thresholds. Each frequency band has its own threshold level, rather than a fixed level that is applied to all bands.

The **Profile-Learn** mode uses a recorded set of band thresholds called a “Profile.” The process for generating a profile is referred to as “Learn.”

The detector is commanded to start and stop the “Learn” process to record the maximum sound level detected in each band during the recording period. This data can be used to reduce sensitivity at the frequency bands where background noise and events are prevalent while increasing sensitivity in the bands that are relatively silent.

To perform the Learn process:

1. Navigate to DEVICE SETUP > ALARM SETUP > PROFILE MODE > LEARN MENU.

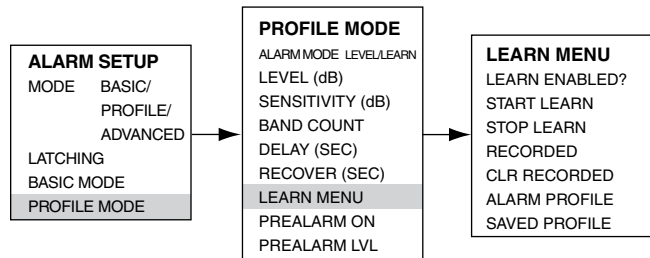

2. Select CLR RECORDED to clear any previous learn data, if desired. Any future learn data will build upon previous results unless this step is performed.
3. Select the START LEARN command to start the learn process. LEARN ENABLED? will indicate 'Y'
4. Select STOP LEARN to stop the learn process. At this point the sequence of START LEARN/STOP LEARN and/or CLR RECORDED may be repeated until the desired profile data is collected. The profile should be characteristic of typical background sounds that may occur during normal operation. If there are periodic events that cause false alarms, it is desirable to conduct the learn process during these events.

- Once the RECORDED data represents the desired profile, navigate to the SAVED PROFILE menu. The SAVED PROFILE menu provides a preview of several slots for permanently storing the RECORDED profile. Navigate to a slot to overwrite. (Use SLOT 1 for a new unit).

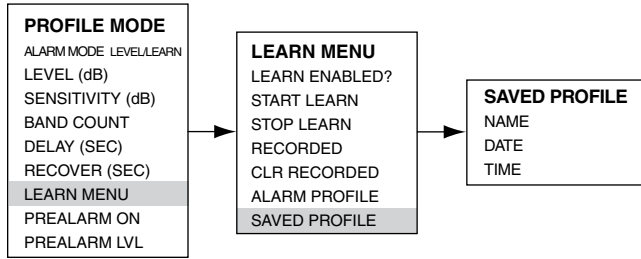

- Select the slot. The menu that appears shows the options of SELECT and SAVE. First select SAVE to copy the RECORDED profile into the SAVED PROFILE slot. Select SELECT to tell the ATX10 to use this SAVED PROFILE slot as its profile for the alarm function.
- Navigate back to the LEARN MENU and confirm that the selected slot's name appears as the ALARM PROFILE.
- Return to the PROFILE MODE menu and set the following parameters as desired:

**SENSITIVITY (dB)** - The actual alarm threshold used in each band is a combination of the profile and this fixed offset. (i.e. a value of 3 would mean each band is counted towards alarm if it exceeds a level 3 higher than its corresponding level in the profile).

**RECOVER (SEC)** – This setting specifies the time (in seconds) that elapses from the moment the alarm criteria are no longer met until the alarm is cleared.

**BAND COUNT** – Similar to **Basic** and **Profile-Level** operation, the band count can be adjusted in **Profile-Learn**. It is preferable to leave the count at the default of 14 or perhaps somewhat higher in **Profile-Learn** mode, since a large sensitivity gain is already realized with the use of a profile. A lower band count may make the detector susceptible to narrow band false alarm sources.

## PREALARM CONFIGURATION

The PREALARM option is available in **Profile-Level/Learn** mode (not **Basic**), and can be configured as follows through the PROFILE MODE menu.

- Set PREALARM ON to 'Y'
- Set PREALARM LVL.

The alarm threshold for each band is lowered by this value, effectively making the band more sensitive. PREALARM is intended to be more sensitive than the normal alarm and can be used as a warning that a potential alarm condition may be imminent.

The number of bands that exceed this lower threshold are counted. When they reach the BAND COUNT setting used for normal alarms, PREALARM will annunciate, resulting in a 16 mA output.

## PASSWORD PROTECTION

The ATX10 allows the use of a password for restricting changes to configuration parameters and limiting access to safety critical commands.

The ATX10 is shipped from the factory with the password protection (Write Protect) feature enabled. Refer to the AC100/ATX10 HART Addendum (number 95-8698) for complete information regarding use of the Write Protect feature.

## GENERAL APPLICATION INFORMATION

### NUISANCE SOURCES

Most industrial or processing environments are relatively free from the higher frequency sound energy that is characteristic of a gas leak, however, there are instances where high frequency nuisance sources exist. The sources may include, but are not limited to:

- Rotating machinery / gear meshes
- Bearings/fans motors
- Metal-to-metal contact / chains
- High velocity wind through rigging

The FlexSonic Acoustic Detector can be effectively employed to record the acoustic background environment unique to an installation and provide a clear display of the information using the Acoustic Inspector software package. The ability to view the actual acoustic environment enables users of the FlexSonic Acoustic Detector to make intelligent, data-based decisions on how to best address nuisance sources in the alarm profile.

### FRIENDLY LEAKS

The FlexSonic Acoustic Detector recognizes the acoustic signature of pressurized gas escaping. Therefore, so called 'friendly' sources of compressed gas leaks such as air lines and relief stacks may be detected as well.

While some non-hazardous pressurized gas escapes may be effectively ignored through the patented learn function, the expected hazardous leak SPL must be greater than the non-hazardous leak SPL for the detector to effectively discriminate between the two sources.

If the time duration of the non-hazardous source is relatively short, the user settable alarm delay setting can be adjusted to reject short duration leaks. Refer to the "Operation" section of this manual for details on alarm adjustments.

## MAINTENANCE

### IMPORTANT

*Periodic flamepath inspections are not recommended, since the product is not intended to be serviced and provides proper ingress protection to eliminate potential deterioration of the flamepaths.*

*The AC100 Sensor contains no user serviceable components and should never be opened. The ATX10 wiring compartment is the only part of the acoustic detector that should be opened by the user in the field.*

### NOTE

*Refer to the FlexSonic Acoustic Detector Safety Manual 95-8658 for specific requirements and recommendations applicable to the proper installation, operation, and maintenance of all SIL-Certified acoustic detectors.*

To maintain maximum sensitivity and detection range, the AC100 Acoustic Sensor cover (and optional foam insert) must be kept relatively clean and free of debris. Refer to the following procedure for cleaning instructions.

## ROUTINE INSPECTION

Periodically or during scheduled maintenance, the AC100 cover should be inspected to ensure that obstructions such as plastic bags, litter, heavy oil and tar, paint, mud, snow, or other materials do not block sound from reaching the sensor and thereby impairing the performance of the device.

When using the optional foam insert in dirty or dusty environments, check to ensure the insert is clean and free of buildup. Replace the insert if torn or damaged.

## CLEANING

To clean the AC100 Acoustic Sensor cover, ensure that the device is powered off, then simply grasp the cover assembly and twist counterclockwise. See Figure 18. The stainless steel mesh can be cleaned with warm soapy water and rinsed. Remove any excess water with a cloth, then air dry.

The foam insert (if used) can also be cleaned with warm, soapy water and rinsed. Hand wring any excess water by simply squeezing the foam insert to remove excess water.

When re-installing the foam insert / AC100 cover, use care not to over tighten.

### CAUTION

*The AC100 sensor head (microphone and AIC acoustic source) does not require cleaning and should not be contacted with any cleaning materials.*

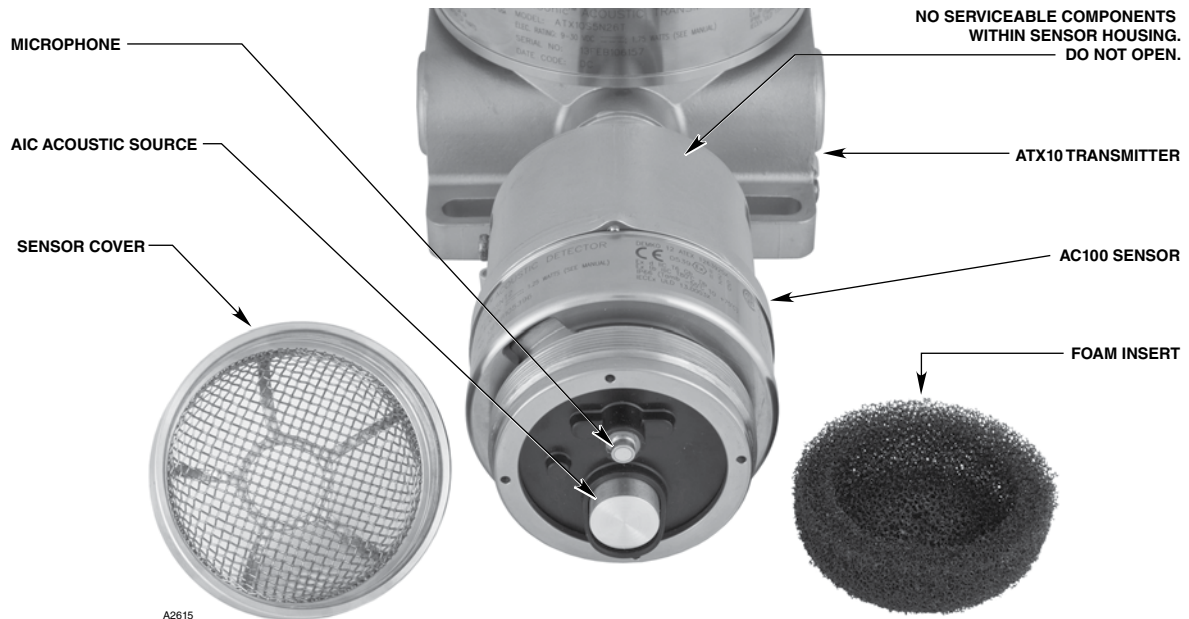

Figure 18—Acoustic Detector with Protective Sensor Cover Removed

## TROUBLESHOOTING

If a Fault condition is indicated by the LED on the ATX10 faceplate, the nature of the fault can be determined by navigating to the STATUS INFO MENU. See Table 3 for additional information.

Table 3—Troubleshooting Guide

Fault Indication	Description	Corrective Action
AI FAULT	AIC has failed. Microphone or emitter is degraded.	Provide data log information to Det-Tronics for analysis.
SD ADVISORY	SD Memory Module has an issue that requires intervention via the SD ADVISORY menu.	SD card is out-of-sync with the ATX10 on-board flash. It will be necessary to either UPLOAD the data to the SD card or DOWNLOAD the data to the ATX10 if the SD card contains valid data (via SD ADVISORY MENU).
SNSR HDWR FAULT	Hardware fault on the AC100 Sensor.	Return to factory for repair.
TX HDWR FAULT	Hardware fault on the ATX10 Transmitter.	Return to factory for repair.
VOLTAGE FAULT	Detector operating voltage is out of tolerance.	Check output voltage at the power source. Check power wiring to the detector.

## DEVICE REPAIR AND RETURN

Prior to returning devices, contact the nearest local Detector Electronics office so that a Return Material Authorization (RMA) number can be assigned. **A written statement describing the malfunction must accompany the returned device or component to assist and expedite finding the root cause of the failure.**

Pack the unit properly. Always use sufficient packing material. Where applicable, use an antistatic bag as protection from electrostatic discharge. The RMA number should be clearly marked on the outside of the box.

### NOTE

***Det-Tronics reserves the right to apply a service charge for repairing returned product damaged as a result of improper packaging.***

Return all equipment transportation prepaid to the factory in Minneapolis.

### NOTE

***It is highly recommended that a spare be kept on hand for field replacement to ensure continuous protection.***

## ORDERING INFORMATION

One AC100 Acoustic Sensor with its associated ATX10 Transmitter is required for each detection point. The two devices can be ordered separately, or as a kit (Kit includes individually packaged AC100 and ATX10). Refer to the appropriate Model Matrix for ordering details. Note: the ATX10 is supplied with memory module and SD card.

Part Number	Description
012152-001	AC100/ATX Kit, 3/4" NPT AC100SNT2 & ATX10S5N26T
012153-001	AC100/ATX Kit, M25 AC100SMT2 & ATX10S5M26T

## REPLACEMENT PARTS

Part Number	Description
010969-001	ATX10 Replacement Module
011365-002	Memory Module (w/o SD card)
104155-001	Micro SDHC Card, 4G, Industrial Temperature Rating
103028-027	Plug, 5.0 mm, 4 Position (P1)
103028-028	Plug, 5.0 mm, 5 Position (J3)

## ACCESSORIES

Part Number	Description
011355-001	Foam Insert for AC100
226365-603	STB7S5YW M25 Sensor Termination Box, (Stainless Steel model only)
226365-604	STB7S5NW 3/4 NPT Sensor Termination Box, (Stainless Steel model only)
012402-001	W6300S1004 Inspector Connector (software not included)
012400-001	Acoustic Inspector Package
012401-001	Acoustic Configurator Package
009700-001	Magnetic Tool
101197-004*	Stop Plug, 3/4" NPT, SS
101197-003	Stop Plug, M25, SS, IP66
005003-001	Lubriplate grease, 1 oz.

\*NEMA Type 4X/IP66 rating requires Teflon tape.

## ASSISTANCE

For assistance in ordering a system to meet the needs of a specific application, please contact:

Detector Electronics, LLC  
6901 West 110th Street  
Minneapolis, Minnesota 55438 USA  
Operator: (952) 941-5665 or (800) 765-FIRE  
Customer Service: (952) 946-6491  
Fax: (952) 829-8750  
Web site: [www.det-tronics.com](http://www.det-tronics.com)  
E-mail: [det-tronics@carrier.com](mailto:det-tronics@carrier.com)

### FlexSonic™ AC100 Acoustic Sensor Model Matrix

MODEL	DESCRIPTION			
AC100	Acoustic sensor			
	TYPE	MATERIAL		
	S	Stainless Steel		
		TYPE	THREAD TYPE	
		N	3/4" NPT	
		M	M25	
		TYPE	APPROVALS	
		T	SIL/FM/CSA/ATEX/CE/IECEX	
		TYPE	CLASSIFICATION	
		2	Division/Zone Ex d	

### FlexSonic™ ATX10 Transmitter Model Matrix

MODEL	DESCRIPTION			
ATX10	Transmitter for AC100			
	TYPE	MATERIAL		
	S	Stainless Steel		
		TYPE	# OF OPEN PORTS	
		5	5 Port	
		TYPE	THREAD TYPE	
		N	3/4" NPT	
		M	M25	
		TYPE	OUTPUT	
		26	4-20 mA with HART Protocol	
		TYPE	APPROVALS	
		T	SIL/FM/CSA/ATEX/CE/IECEX	

## APPENDIX A

### FM APPROVAL DESCRIPTION

#### AC100

Class I, Div1, Groups B, C & D  
Class II/III, Div1/Div2, Groups E, F & G  
Class I, Div2, Groups A, B, C & D  
Temperature code T4  
Tamb: -55°C to +75°C  
NEMA 4X

#### ATX10

Class I, Div1, Groups B, C & D  
Class II/III, Div1/Div2, Groups E, F & G  
Temperature code T5  
Class I, Div2, Groups A, B, C & D  
Temperature code T4  
Tamb: -55°C to +75°C  
NEMA 4X

#### Applicable Documents:

FM 3810	Elec. and Electronic Test, Measuring and Process Control Equipment
FM 3600	Electrical Equipment for use in Hazardous (Classified) Locations
FM 3610 (ANSI/ISA 60079-11)	Intrinsically Safe, Class I, II, III, Div I, Haz. Loc.
FM 3611	Elec. Equip. for use in Cl. I/II, Div. 2 and Cl. III, Div. 1/2 Haz. Loc.
FM 3615	Explosionproof Electrical Equipment
NEMA 250	Enclosures for Electrical Equipment (1000 Volts Maximum)

## APPENDIX B

### CSA CERTIFICATION DESCRIPTION

#### AC100

Class I, Div. 1, Groups B, C & D; (T4)  
Class I, Div. 2, Groups A, B, C & D; (T4)  
Class II, Div. 1, Groups E, F & G; (T4)  
Class II, Div. 2, Groups F & G; (T4)  
Class III, Div 1 and 2 (T4)  
Tamb: -55°C to +75°C  
Type 4X

#### ATX10

Class I, Div. 1, Groups B, C & D; (T5)  
Class I, Div. 2, Groups A, B, C & D; (T4)  
Class II, Div. 1, Groups E, F & G; (T5)  
Class II, Div. 2, Groups F & G; (T5)  
Class III, Div 1 and 2 (T5)  
Tamb: -55°C to +75°C  
Type 4X

#### Applicable Documents:

C22.2 #25	Enclosures for use in Class II, Division 1, Groups E, F, G Haz. Loc.
C22.2 #30	Explosion-proof Enclosures for Use in Class I Haz. Loc.
C22.2 #94.2	Enclosures for Electrical Equipment, Environmental Considerations
C22.2 #61010-1	Safety Requirements for Electrical Equipment for Measurement, Control, and Laboratory Use. Part 1: General Requirements
C22.2 #213	Non-incendive Electrical Equipment for Use in Class I, Div 2 Haz. Loc.
C22.2 60079-11:14	Explosive atmospheres - Part 11: Equipment protection by intrinsic safety "I"
C22.2 60079-0:19	Explosive atmospheres - Part 0: Equipment - General requirements

## APPENDIX C

### ATEX AND UKEX APPROVAL DESCRIPTION

#### AC100



#### ATX10



#### EN Standards:

EN IEC 60079-0: 2018	Electrical apparatus for explosive atmospheres, General Requirements
EN 60079-1: 2014	Electrical apparatus for explosive atmospheres, Flameproof enclosure “d”
EN 60079-11: 2012	Explosive atmospheres Equip protection by Intrinsic Safety
EN 60079-31: 2014	Explosive atmospheres Equip. Dust Ignition Protection by enclosure “t”

#### ATEX Special Conditions for Safe Use ('X'):

##### AC100

- The AC100 Acoustic Sensor must always be installed with the detection head pointing down vertically.
- The AC100 Acoustic Sensor must only be installed in areas where there is a low risk of mechanical damage.
- The AC100 is only to be used connected to the ATX10 Acoustic Transmitter or Model STB Sensor Termination Box.
- The metal housing must be electrically connected to earth ground.
- The ambient temperature range is limited to -55 °C to +75 °C.
- The intrinsic safety circuits in the AC100 are internally connected to ground (frame).
- Periodic flamepath inspections are not recommended, since the product is not intended to be serviced and provides proper ingress protection to eliminate potential deterioration of the flamepaths.

##### ATX10

- The ATX10 must only be installed in areas where there is a low risk of mechanical damage.
- Periodic flamepath inspections are not recommended, since the product is not intended to be serviced and provides proper ingress protection to eliminate potential deterioration of the flamepaths.

#### Additional Safety Notes:

- The following warning is on the product: Warning: Do not open when an explosive gas atmosphere may be present. For ambient temperature above 60°C use field wiring suitable for maximum ambient temperature. For temperature below -10°C use suitable field wiring for the lowest temperature.
- Cable, bushings and the conduit entries shall be of a flameproof type already certified according to relevant ATEX standard, so the protection principle employed will not be impaired.
- Unused conduit entries shall be closed using flameproof stop plugs certified for the conditions of use (IP6x minimum). The stop plugs should be removable only with the aid of a tool.
- Shielded cable is required.

## APPENDIX D

### IECEX APPROVAL DESCRIPTION

#### AC100

IECEX UL 22.0058X  
Ex db ib IIC T4 Gb  
Ex tb IIIC T80°C Db  
Tamb: -55°C to +75°C

#### ATX10

IECEX UL 22.0056X  
Ex db IIC T6 Gb  
Ex tb IIIC T80°C Db  
Tamb: -55°C to +75°C

#### IEC Standards:

IEC60079-0 7th edition	Electrical apparatus for explosive atmospheres, General Requirements
IEC60079-1 7th edition	Electrical apparatus for explosive atmospheres, Flameproof enclosure “d”
IEC60079-11 6th edition	Intrinsic Safety explosive atmospheres Equip protection by Intrinsic Safety
IEC60079-31 2nd edition	Explosive atmospheres Equip. Dust Ignition Protection by enclosure “t”

#### IEC Special Conditions for Safe Use (X):

##### AC100

- The AC100 Acoustic Sensor must always be installed with the detection head pointing down vertically.
- The AC100 Acoustic Sensor must only be installed in areas where there is a low risk of mechanical damage.
- The AC100 is only to be used connected to the ATX10 Acoustic Transmitter or Model STB Sensor Termination Box.
- The metal housing must be electrically connected to earth ground.
- The ambient temperature range is limited to -55 °C to +75 °C.
- The intrinsic safety circuits in the AC100 are internally connected to ground (frame).
- Periodic flamepath inspections are not recommended, since the product is not intended to be serviced and provides proper ingress protection to eliminate potential deterioration of the flamepaths.

##### ATX10

- The ATX10 must only be installed in areas where there is a low risk of mechanical damage.
- Periodic flamepath inspections are not recommended, since the product is not intended to be serviced and provides proper ingress protection to eliminate potential deterioration of the flamepaths.

#### WARNING

***Always ensure that the detector/junction box hazardous (classified) location ratings are applicable for the intended use.***

#### Additional Safety Notes:

- The following warning is on the product: Warning: Do not open when an explosive gas atmosphere may be present. For ambient temperature above 60°C use field wiring suitable for maximum ambient temperature. For temperature below -10°C use suitable field wiring for the lowest temperature.
- Cable, bushings and the conduit entries shall be of a flameproof type already certified according to relevant IEC standard, so the protection principle employed will not be impaired.
- Unused conduit entries shall be closed using flameproof stop plugs certified for the conditions of use (IP6x minimum). The stop plugs should be removable only with the aid of a tool.
- Shielded cable is required.

# APPENDIX E

## MARITIME APPROVAL

### DNV GL

Type Approval Certificate No. TAA000017F.

### Subject Matter of the Approval

Model AC100 Acoustic Sensor, ATX10 Transmitter, and STB Termination Box are found to comply with Det Norske Veritas' Rules for Classification of Ships and Det Norske Veritas' Offshore Standards.

### Application/Limitation

Location Classes					
MODEL	TEMPERATURE	HUMIDITY	VIBRATION	EMC	ENCLOSURE
AC100/ATX10	D	B	B	B	C/IP66

Relevant tests according to "Class Guideline DNV GL CG-0339".

### Line Filter

A line filter is required for all maritime installations. Phoenix Contact model ME-MAX-NEF/QUINT20A is approved for use with the AC100/ATX10 Acoustic Detector and must be installed within 12 inches (30 centimeters) of the detector.

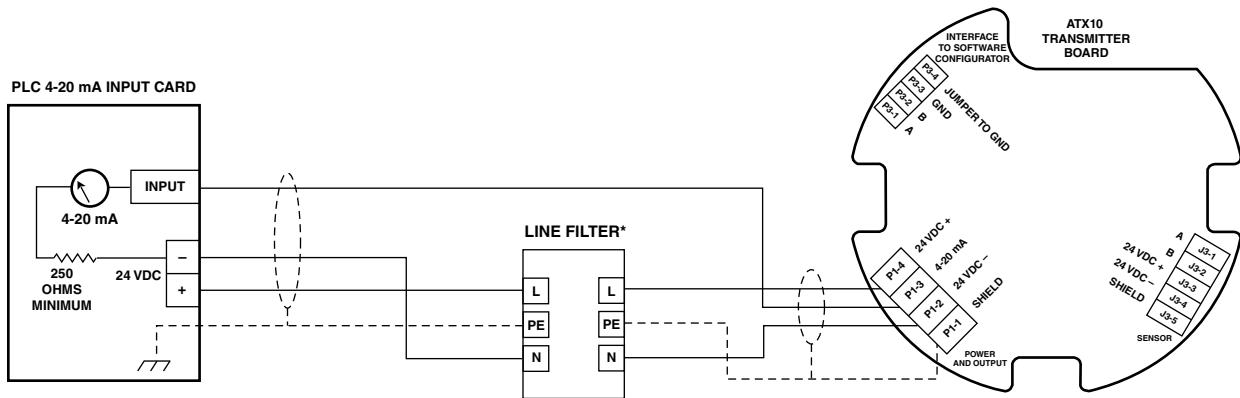

\* LINE FILTER MUST BE LOCATED LESS THAN 12 INCHES (30 CM) FROM ACOUSTIC DETECTOR.

## **APPENDIX F**

### **ADDITIONAL APPROVALS**

#### **RUSSIA & KAZAKHSTAN**



VNIIFTRI  
CERTIFICATE OF CONFORMITY TO "TP TC 012/2011"

#### **Sensor AC100**

№ TC RU C-US. BH02.B.00762/22

1Exd[ib]IICT4 IP66

T4 (Tamb = -55°C to +75°C)

#### **Transmitter ATX10**

№ TC RU C-US. BH02.B.00763/22

1ExdIICT6 IP66

T4 (Tamb = -55°C to +75°C)

DECLARATION OF CONFORMITY TO "TP TC 020/2011 EMC"

(Sensor AC100 and Transmitter ATX10)

EAЭC N RU Д-US.PA03.B.75004/21

# APPENDIX G

## APPROVED ADJOINING ASSEMBLIES

DIRECT CONNECTION



AC100 with ATX10

REMOTE SENSOR

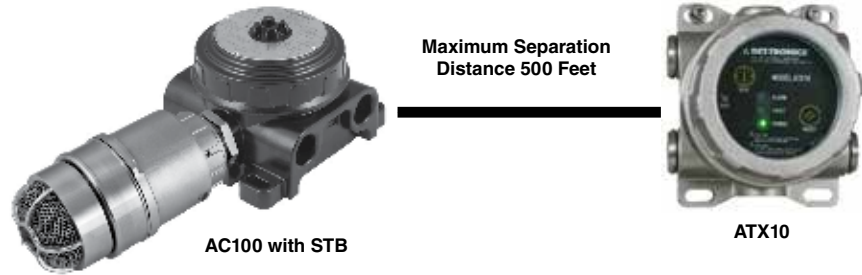

AC100 with STB

ATX10

WITH UNIVERSAL DISPLAY

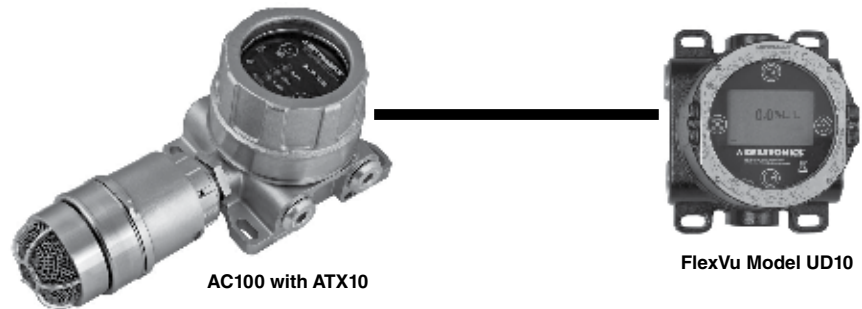

AC100 with ATX10

FlexVu Model UD10

### WARNING

*The AC100 must be connected as shown above for compliance with hazardous (classified) location requirements.*



95-8657



FlexSonic™ Acoustic  
Leak Detector



X3301 Multispectrum  
IR Flame Detector



PointWatch Eclipse® IR  
Combustible Gas Detector



FlexVu® Universal Display  
with GT3000 Toxic Gas Detector



Eagle Quantum Premier®  
Safety System

