

# Instructions

xWatch® Explosion-Proof Camera  
Model X7050



# Table Of Contents

DESCRIPTION .....	1
FEATURES .....	1
GENERAL APPLICATION INFORMATION .....	2
SPECIFICATIONS .....	3
IMPORTANT SAFETY NOTES .....	4
INSTALLATION .....	4
Protection Against Moisture Damage .....	4
Camera Location .....	5
Camera Mounting .....	5
Wire Size and Type .....	5
Wiring Procedure .....	6
Aiming the Camera .....	7
Leveling the Camera .....	7
CONVERTING A C7050 FLAME DETECTOR TO A MODEL X7050 CAMERA .....	8
TROUBLESHOOTING .....	9
Replacing the xWatch Camera Module .....	9
MAINTENANCE .....	9
Cleaning .....	9
O-Rings .....	9
DEVICE REPAIR AND RETURN .....	10
ORDERING INFORMATION .....	10
Accessories .....	10
Replacement Parts .....	10
Assistance .....	10
xWatch Model Matrix .....	11
APPENDIX A – FM / CSA APPROVAL .....	12
APPENDIX B – ATEX / IECEx APPROVAL .....	13

## INSTRUCTIONS

### xWatch® Explosion-Proof Camera Model X7050

#### **IMPORTANT**

*Be sure to read and understand the entire instruction manual before installing or operating the system. Any deviation from the recommendations in this manual may impair system performance and compromise safety.*

#### **DESCRIPTION**

The xWatch® Explosion-Proof Camera Model X7050 produces a high resolution color video picture using a camera module that is mounted inside an explosion-proof NEMA 4X rated housing. The device's explosion-proof rating makes it suitable for Class I, Div. 1, Groups B, C and D locations. The camera can be used alone or in combination with fire and gas detectors in any application that requires CCTV surveillance capabilities.

The xWatch Camera can be used in any of three configurations:

- It can be used as a stand alone device to perform typical CCTV functions.
- The camera module can be retrofitted in place of the UV tube module in an existing C7050 Flame Detector to provide basic visual information.
- The camera can be ordered from the factory as a combined unit with any X-Series flame detector. With this arrangement, the camera and detector share the same field of view.

In the event of a fire or gas alarm, the operator can immediately view the monitored area to determine whether personnel are present and safe. An accurate evaluation of the hazard's size, nature, location and severity can be determined quickly and safely.

The use of a digital video recorder (DVR) to capture the event provides a permanent record for future analysis of what occurred.



#### **FEATURES**

- Low cost surveillance of any flame, gas, or toxic hazard location
- Parallel, non-interfering operation with hazard detection system
- Easy connection to a video switcher using twisted pair wiring
- Use existing wiring if suitable
- Easy retrofit into standard C7050 housing
- Simple no tool exchange of the tube module to camera
- Compact housing for easy installation in small spaces
- 3 lens options (wide, normal, or narrow) for flexible field-of-view:
  - Wide lens emulates a flame detector's field of view
  - Normal lens is ideal of monitoring general areas
  - Narrow lens enables up-close viewing
- Ideally suited for remote and/or inaccessible areas
- Informed, appropriate response to incidents
- Pre- and post-event analysis of video recording

## GENERAL APPLICATION INFORMATION

The xWatch Explosion-Proof Camera Model X7050 has a balanced differential video output for driving a long distance twisted pair signal to a remote site for monitoring and/or recording. The video output format can be either NTSC (National Television Systems Committee) or PAL (Phase Alternating Line).

The video driver of the camera is designed for use with twisted pair cable of 100 ohm impedance. The best video performance in terms of distance, video quality, and cost is attained using 22 AWG to 16 AWG, twisted pair cable of 100 ohm impedance.

The monitor end must terminate the video cable with 100 ohms. Since most monitors have a built-in termination resistor of 75 ohms instead of 100 ohms, a balun or other matching network (video converter) must be used.

A variety of matrix control systems or DVRs can be suitable for viewing or recording the video signal, depending on the requirements of the individual application. The detector's auxiliary relay contacts are typically used to signal the video system of an alarm event.

Refer to Figure 1 for a schematic of a typical system.

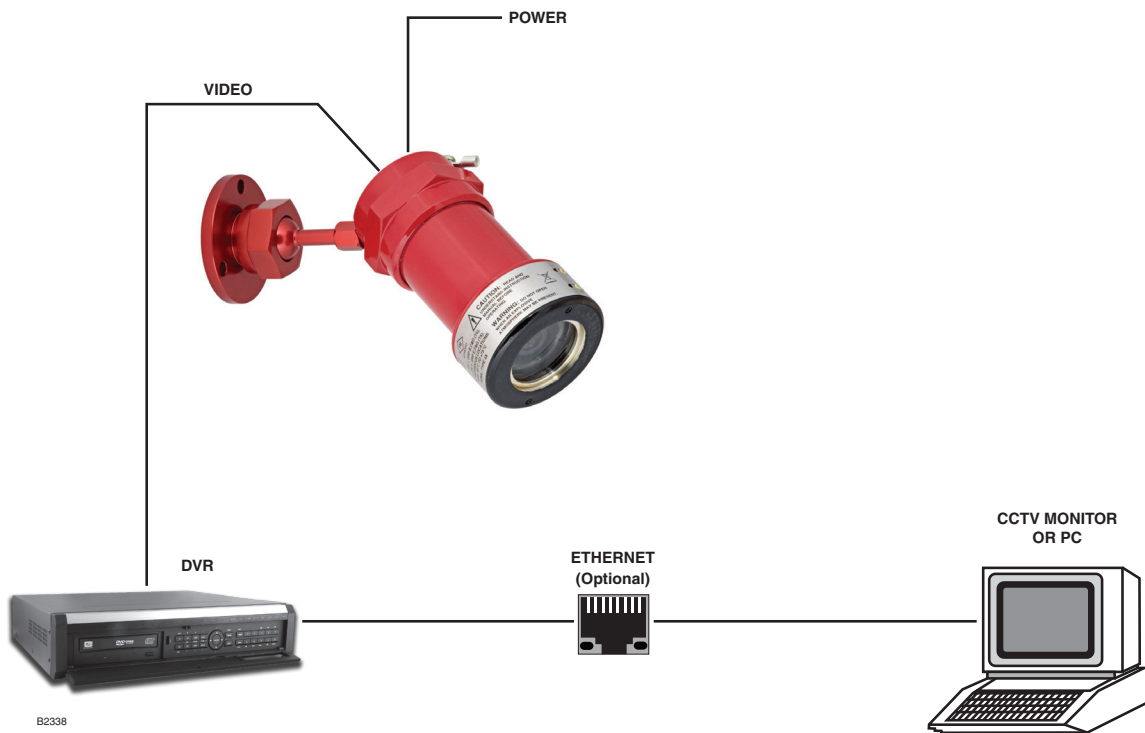

Figure 1—System Block Diagram

## SPECIFICATIONS

**OPERATING TEMPERATURE—**  
 -20°C to +70°C

**HAZARDOUS LOCATION RATING—**  
 -40°C to +75°C

**STORAGE TEMPERATURE—**  
 -30°C to +80°C

**RELATIVE HUMIDITY—**  
 5 to 95%, non-condensing

**INGRESS PROTECTION—**  
 NEMA/Type 4X

**SENSOR—**  
 Color low light CCD, 0.3 lux

**RESOLUTION—**  
 NTSC: 768 by 494 pixels, 570 lines of resolution  
 PAL: 752 by 582 pixels, 570 lines of resolution

**VIDEO OUTPUT—**  
 NTSC or PAL two wire twisted pair, unshielded,  
 Category 5

**SHUTTER—**  
 Electronic shutter, 1/60 – 1/100,000 second

**OPERATING VOLTAGE—**  
 24 Vdc nominal, 18 to 30 Vdc

**POWER CONSUMPTION—**  
 2.8 watts

- FIELD OF VIEW OPTIONS—**
- 90 degrees, 2.33 mm lens, wide angle to match field of view of flame detector.
  - 50 degrees, 4.33 mm lens, normal angle for general duty.
  - 30 degrees, 8.0 mm lens, narrow angle for focus on a specific point of interest.

(NOTE: FOV degrees are approximates)

**USER INTERFACE—**  
 Conventional off-the-shelf video switchers or digital video recorders (DVR) can be used for the interface.

**HOUSING MATERIAL—**  
 Aluminum or 316 Stainless Steel

**SHIPPING WEIGHT (Approximate)—**  
 Aluminum: 1.2 pounds (0.6 kg)  
 Stainless Steel: 2.2 pounds (1.0 kg)

**DIMENSIONS—**  
 See Figures 2, 3 and 4.

## CERTIFICATIONS—



For complete approval details for the xWatch Explosion Proof Camera Model X7050, refer to the appropriate Appendix:

Appendix A - FM/CSA  
 Appendix B - ATEX/IECEx.

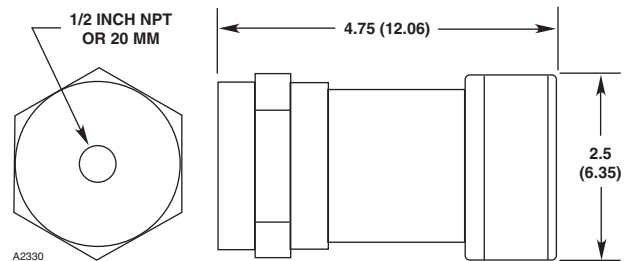

Figure 2— xWatch Camera Dimensions in Inches (Centimeters)

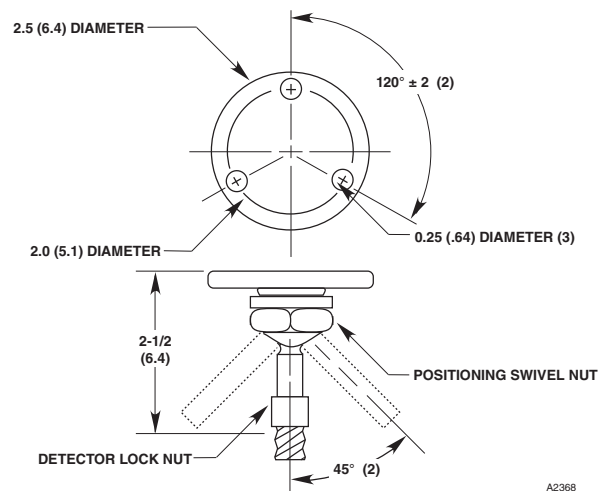

Figure 3—Dimensions of Q9001A Aluminum Mounting Bracket in Inches (Centimeters)

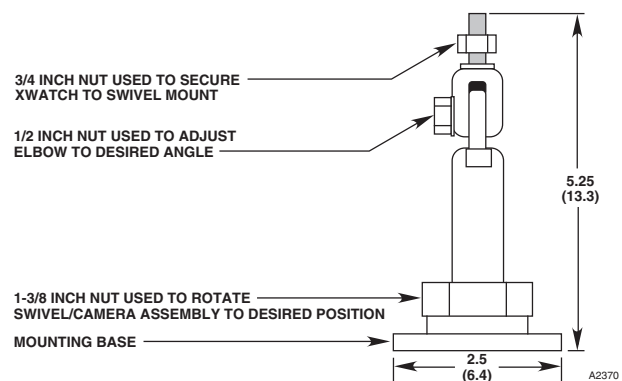

Figure 4—Dimensions of Q9001H Stainless Steel Mounting Bracket in Inches (Centimeters)

## IMPORTANT SAFETY NOTES

### **WARNING**

*Do not open the camera assembly in a hazardous area when power is applied. The device contains no serviceable components and should not be opened, except during installation and setup.*

### **CAUTION**

*The wiring procedures in this manual are intended to ensure proper functioning of the device under normal conditions. However, because of the many variations in wiring codes and regulations, total compliance to these ordinances cannot be guaranteed. Be certain that all wiring complies with the NEC as well as all local ordinances. If in doubt, consult the authority having jurisdiction before wiring the system.*

### **ATTENTION**

*Observe precautions for handling electrostatic sensitive devices. Do not plug the camera module into the base with power applied.*

## INSTALLATION

### **CAUTION**

*Installation and wiring of the Model X7050 Camera should be performed only by qualified personnel.*

### **PROTECTION AGAINST MOISTURE DAMAGE**

It is important to take proper precautions during installation to ensure that moisture will not come in contact with the electrical connections or components of the system. The integrity of the system regarding moisture protection must be maintained for proper operation and is the responsibility of the installer.

If conduit is used, drains must be installed at water collection points to automatically drain accumulated moisture. Conduit breathers should be installed at upper locations to provide ventilation and allow water vapor to escape. At least one breather should be used with each drain.

Conduit raceways should be inclined so that water will flow to low points for drainage and will not collect inside enclosures or on conduit seals. If this is not possible, install conduit drains above the seals to prevent the collection of water or install a drain loop below the camera with a conduit drain at the lowest point of the loop.

Conduit seals are not required for compliance with explosion-proof installation requirements, but are highly recommended to prevent water ingress in outdoor applications. Units with M25 thread must use an IP66 washer to prevent water ingress.

## CAMERA LOCATION

Cameras should be positioned to provide the best unobstructed view of the area to be monitored. If the camera is to monitor the same area as the detector, it should be mounted as close to the detector as practical. The following factors should also be taken into consideration:

- Be sure that the unit is easily accessible for cleaning and other periodic servicing.
- Care must be taken to ensure that dirt, moisture or other contaminants will not accumulate on the lens and obscure the vision of the camera. If possible, point the camera slightly downward.
- The camera should be mounted on a rigid surface in a low vibration area.
- The camera should not be placed where rising combustion products can obscure its vision. If dense smoke is expected to accumulate at the onset of a fire, the camera should be mounted on a side wall at least a few feet (approximately 1 meter) down from the ceiling.

## CAMERA MOUNTING

Install the swivel mounting bracket assembly on the wall. The installation surface should be free of vibration and suitable to receive 1/4 inch (M6) screws with a length of at least 1 inch (25 mm), and have sufficient capacity to hold the camera and bracket weight.

## WIRE SIZE AND TYPE

### General

The preferred wiring system for the xWatch Camera Model X7050 utilizes unshielded twisted pair for the video signal. Power wiring requires a wire gauge large enough to ensure that 18 Vdc is available to the device at all times.

### NOTE

*In applications where the wiring cable is installed in conduit, the conduit must not be used for wiring to other electrical equipment.*

## Video Cable Considerations

Proper video cable will ensure that the best quality video is displayed on a remote monitor. Because composite video frequencies span the range of 25 Hz to 6 MHz, most cables will display transmission line characteristics. Ensure that the same cable type (impedance) is used throughout the entire length. For example, do not mix twisted pair cable and coaxial cable without using a balun for matching. In addition, the monitor end must be properly terminated. Failure to properly implement the video cabling system may result in smearing (loss of detail) and/or loss of color and/or loss of picture sync. The camera employs a balanced differential video driver designed to drive twisted pair cable of 100 ohm impedance. The best video performance in terms of distance, video quality, and cost is attained using a 22 AWG to 16 AWG unshielded twisted pair cable of 100 ohm impedance. The wiring can be Category 2 or better, stranded or solid.

The monitor end must terminate the video cable with 100 ohms. Most monitors have a built in termination resistor. If the monitor uses 75 ohms instead of 100, a balun or other matching network must be used.

There are manufacturers who support driving many types of cable systems using active transceivers that compensate for cable losses.

Galvanic isolation of the video may also be necessary to avoid horizontal bars caused by line frequency interference. This may be accomplished using isolating active transceiving systems or passive video isolation transformers/baluns. Specify a baseband video isolation system with a frequency response of at least 25 Hz to 6 MHz. Small cable TV transformers will generally not work as their frequency response is not low enough.

## Power Cable Considerations

To ensure proper operation, a minimum of 18 Vdc is required at the terminal block of the camera, considering a worst case current draw of 0.156 Amps (2.8 Watts).

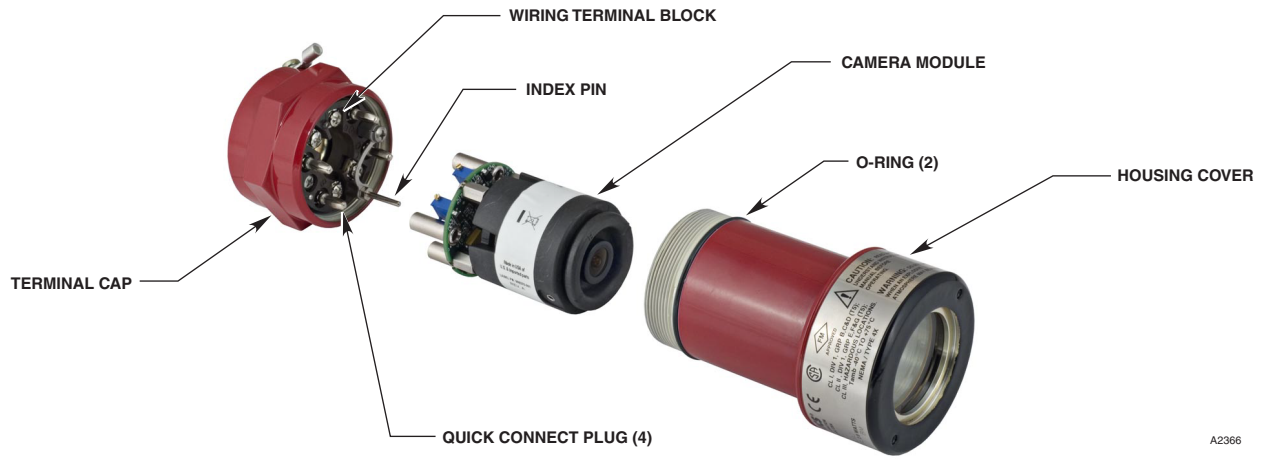

A2366

Figure 5—Exploded View of xWatch Camera

## WIRING PROCEDURE

### CAUTION

*Power must not be applied to the device while opening the housing or while plugging in or removing the module.*

1. Disassemble the enclosure by turning the housing cover counterclockwise. See Figure 5 for an illustration of the camera assembly.
2. Carefully remove the camera module.
3. Connect the external wiring to the screw connectors marked A-, B-, C-, and D- on the camera terminal block. See Figure 6.

### IMPORTANT

*Do not test any wiring connected to the camera with a meg-ohmmeter. Disconnect wiring at the camera before checking system wiring for continuity.*

4. Check all field wiring to be sure that the proper connections have been made.
5. Using the index pin as a guide, install the camera module on the terminal block.
6. Re-assemble the device housing.
7. Make the final sighting adjustments and ensure that the mounting bracket hardware is tight.

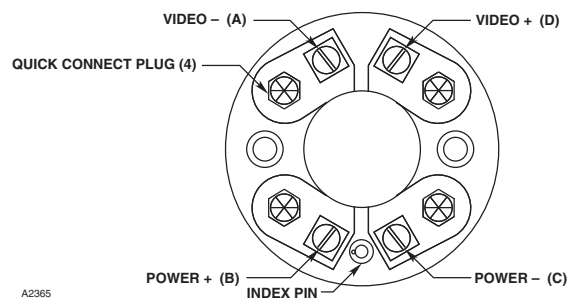

A2365

Figure 6—xWatch Camera Wiring Terminal Block



## AIMING THE CAMERA

In installations where the Model X7050 Camera is used for monitoring the same hazardous area as a single detector, the recommended procedure for ensuring that the camera is correctly aligned with the detector's cone of vision is to use a Cone of Vision Tester (Laser Aimer) available from Detector Electronics Corporation (Det-Tronics®).

1. Using the COV tester, locate the center of the detector's field of view. (Refer to the instruction manual provided with the COV tester for complete information regarding its use.)
2. Place the COV tester on the camera. Loosen the mounting bracket, then adjust the center of the camera's field of view to match the center of the detector's field of view.

The COV tester can also be used to locate the outside edge of the field of view.

## LEVELING THE CAMERA

If the image on the monitor does not appear to be level, this can be corrected by rotating the camera module within the xWatch Camera.

1. Remove the housing cover from the xWatch Camera. See Figure 5.
2. Loosen the setscrew on the side of the camera module. See Figure 7.
3. Align the two notches on the face of the module so that they are level with the horizon or until the image on the monitor looks level.
4. When proper orientation has been achieved, carefully tighten the setscrew. Do not overtighten.

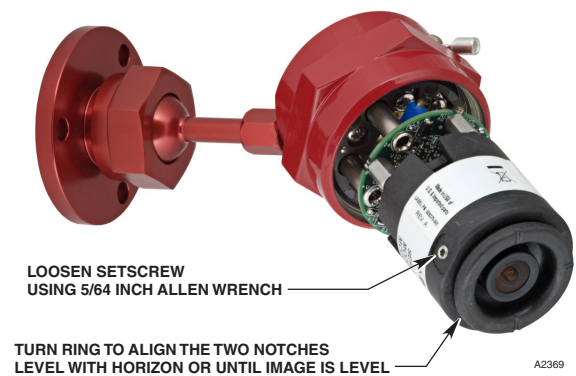

Figure 7—xWatch Camera Module

## CONVERTING A C7050 FLAME DETECTOR TO A MODEL X7050 CAMERA

The Model X7050 Camera module can be installed in place of the UV tube module in an existing C7050 Flame Detector to provide basic visual monitoring capability.

### CAUTION

*Under no circumstances can 290 Vdc be applied to the camera.*

1. Provide the correct wiring to the C7050/X7050 location as described in "Wire Size and Type" in the Installation section of this manual.

### CAUTION

*Power must not be applied to the device while opening the housing or while plugging in or removing the module.*

2. Disassemble the enclosure by turning the housing cover counterclockwise. See Figure 8 for an illustration of the xWatch Camera assembly.

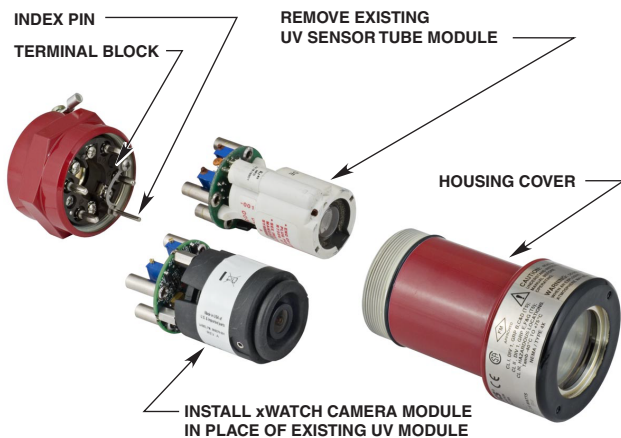

B2331

NOTE: REQUIRES REWIRING TO VIDEO EQUIPMENT.

Figure 8—Converting C7050 Flame Detector to X7050 Camera

3. Remove the existing UV module from the C7050 detector.
4. Disconnect the existing wiring at the controller. Connect the grounding strap between the new index pin and the terminal mounting screw per the instructions. See Figure 9.

### IMPORTANT

*Do not test any wiring connected to the xWatch Camera with a meg-ohmmeter. Disconnect wiring at the camera before checking system wiring for continuity.*

5. Check all field wiring to be sure that the proper connections have been made.
6. Using the index pin as a guide, install the xWatch Camera module on the terminal block.
7. Re-assemble the device housing.
8. Make the final sighting adjustments and ensure that the mounting bracket hardware is tight.

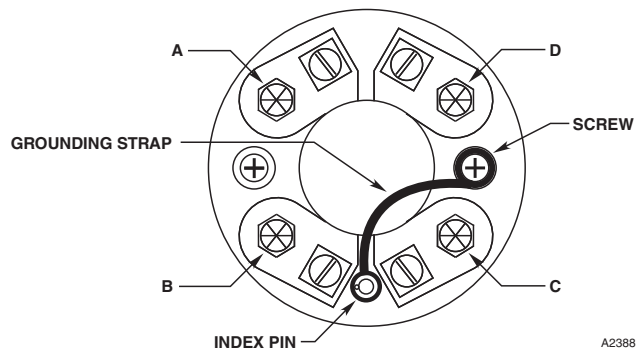

A2388

Figure 9—X7050 Camera Terminal Block

## TROUBLESHOOTING

The xWatch Camera is not designed to be repaired in the field. If it is determined that the problem is caused by an electronic defect, the device must be returned to the factory for repair.

### NOTE

*It is highly recommended that spare modules be kept on hand for field replacement to ensure continuous protection.*

## REPLACING THE XWATCH CAMERA MODULE

### CAUTION

*Power must not be applied to the device while opening the housing or while plugging in or removing the module.*

1. Disassemble the enclosure by turning the housing cover counterclockwise. See Figure 5 for an illustration of the xWatch Camera assembly.
2. Remove the existing camera module.
3. Using the index pin as a guide, install the new camera module on the terminal block.
4. Check the housing O-rings and service as required (see Maintenance section of this manual for details). Re-assemble the device housing.
5. Check camera sighting and ensure that the mounting bracket hardware is tight.
6. Clean the camera lens if required.

## MAINTENANCE

### CLEANING

The camera requires no periodic calibration or servicing. However, the camera lens should be cleaned on a regular basis.

Clean the camera lens using a clean cloth or tissue and Det-Tronics window cleaning solution (part number 001680-001). If a stronger solution is needed, isopropyl alcohol may be used.

### O-RINGS

Rubber O-rings are used on the Model X7050 Camera housing to ensure the watertight integrity of the device. It is imperative that these O-rings be properly installed and in good condition. Failure to properly maintain these rings can allow water to enter the housing and cause premature failure.

When the housing cover is removed, the O-rings should be inspected for breaks, cracks, or dryness. If cracks are visible, the O-ring should be replaced. If they feel dry to the touch, a thin coating of lubricant should be applied. When re-installing the O-rings, be sure that they are properly seated in the groove on the housing.

A coating of lubricant should also be applied to the threads on the housing before reassembly. This will both lubricate the threads and help to prevent moisture from entering the housing.

### CAUTION

*O-rings should be lubricated with a silicone-free grease (such as p/n 005003-001 available from Det-Tronics). If catalytic type combustible gas sensors are being used anywhere on the premises, silicone based lubricants should never be used, since inadvertent use of a silicone lubricant on or near the combustible gas sensor will cause irreversible damage to the sensing element.*

## DEVICE REPAIR AND RETURN

Prior to returning devices, contact the nearest local Detector Electronics office so that a Return Material Identification (RMI) number can be assigned. **A written statement describing the malfunction must accompany the returned device or component to assist and expedite finding the root cause of the failure.**

Pack the unit properly. Always use sufficient packing material. Where applicable, use an antistatic bag as protection from electrostatic discharge.

### NOTE

*Det-Tronics reserves the right to apply a service charge for repairing returned product damaged as a result of improper packaging.*

Return all equipment transportation prepaid to the factory in Minneapolis.

## ORDERING INFORMATION

When ordering, please specify:

xWatch Explosion Proof Camera Model X7050

Refer to the xWatch Model Matrix below for details.

### ACCESSORIES

**Swivel Mount Bracket** is required for mounting the camera:

- Q9001B1175 Aluminum Mounting Bracket (p/n 002099-003)
- Q9001H8001 Stainless Steel Mounting Bracket (p/n 004404-002)

**Q1201A Laser Holder/Laser** is used for sighting the flame detector and xWatch Camera. The Laser Holder easily attaches to the front of the detector or camera. The Laser projects a red laser beam to show the exact center of the field of view. Additional laser positions are provided to show the outside edges of the field of view.

## REPLACEMENT PARTS

### Part Number Description

009448-003	Model DE2020N – Replacement Camera Module, 2.33 mm, NTSC
009448-004	Model DE2020P – Replacement Camera Module, 2.33 mm, PAL
009448-005	Model DE2022N – Replacement Camera Module, 4.3 mm, NTSC
009448-006	Model DE2022P – Replacement Camera Module, 4.33 mm, PAL
009448-007	Model DE2023N – Replacement Camera Module, 8.0 mm, NTSC
009448-008	Model DE2023P – Replacement Camera Module, 8.0 mm, PAL
107427-004	Rubber O-rings
001680-001	Window cleaner squeeze bottle (package of six bottles)
005003-001	Silicone-free grease

## ASSISTANCE

For assistance in ordering a system to meet the needs of a specific application, contact:

Detector Electronics Corporation  
6901 West 110th Street  
Minneapolis, Minnesota 55438 USA  
Operator: (952) 941-5665 or (800) 765-FIRE  
Customer Service: (952) 946-6491  
Fax: (952) 829-8750  
Web site: [www.det-tronics.com](http://www.det-tronics.com)  
E-mail: [det-tronics@det-tronics.com](mailto:det-tronics@det-tronics.com)

## xWATCH MODEL MATRIX

MODEL	DESCRIPTION	
<b>X7050</b>	xWatch Explosion Proof Camera	
	TYPE	MATERIAL
	<b>A</b>	Aluminum
	<b>S</b>	Stainless Steel (316)
	TYPE	THREAD TYPE
	<b>1E</b>	1/2" NPT
	<b>1F</b>	M20
	TYPE	VIDEO OUTPUT
	<b>50</b>	NTSC
	<b>51</b>	PAL
	TYPE	FIELD OF VIEW
	<b>1</b>	Wide FOV (90°), 2.3 mm Lens*
	<b>2</b>	Normal FOV (50°), 4.3 mm Lens
	<b>3</b>	Narrow FOV (30°), 8.0 mm Lens
	TYPE	APPROVALS
	W	FM/CSA/ATEX/CE/IECEX
	TYPE	CLASSIFICATION
	<b>2</b>	Division/Zone Ex d

\*This lens emulates the 90° field of view to match the X-Series Flame Detectors

# APPENDIX A

## FM / CSA APPROVAL

### FM CERTIFICATION

**CERTIFICATE OF COMPLIANCE** - Hazardous (Classified) Location Electrical Equipment  
Explosion-proof for Class I, Division 1, Groups B, C, and D; and dust ignition-proof for Class II/III, Division 1, Group E, F, and G T5 Ta = 75°C hazardous (classified) locations, indoors and outdoors (Type 4X).

### APPLICABLE STANDARDS

Electrical and Electronic Test, Measuring and Process Control Equipment, Class 3810, 2005.  
Electrical Equipment for Use in Hazardous (Classified) Locations, General Requirements, 3600, 1998.  
Explosionproof Electrical Equipment, General Requirements, 3615, 2006.  
Enclosures for Electrical Equipment, ANSI/NEMA 250, 2003.

### CSA CERTIFICATION

**CLASS 4818 01** - SIGNAL APPLIANCES - Systems - For Hazardous Locations  
Class I, Division 1, Groups B, C, and D (T5); Class II/III, Division 1, Groups E, F, and G (T5); Enclosure NEMA/Type 4X;  
xWatch Model X7050 Video Camera, NTSC or PAL system video output, rated 18-30 Vdc, 2.8 Watts maximum.

### APPLICABLE REQUIREMENTS

- CSA Std C22.2 No. 25-1996 – Enclosures for use in Class II Groups E, F & G Hazardous Locations.
- CSA Std C22.2 No. 30-M1986 – Explosion-Proof Enclosures for use in Class I Hazardous Locations.
- CAN/CSA C22.2 No. 94-M91 – Special Purpose Enclosures.
- CSA Std C22.2 No. 142-M1987 – Process Control Equipment.

# APPENDIX B

## ATEX / IECEx APPROVAL

### ATEX CERTIFICATION

CE 0539 Ⓢ II 2 G  
Ex d IIC T5 Gb  
FM07ATEX0053  
T5 (Tamb = -40°C to +75°C)  
IP66.

EN Standards: EN 60079-0: 2009  
EN 60079-1: 2007  
EN 60529: 1991+A1: 2000.

#### Special Conditions for Safe Use:

None.

### IECEX CERTIFICATION

Certificate of Conformity  
IECEX FMG 07.0019  
Ex d IIC T5 Gb  
T5 (Tamb = -40°C to +75°C)  
IP66.

IEC Standards: IEC 60079-0: 2007  
IEC 60079-1: 2007  
IEC 60529: 2001.



95-8600



FlexSonic® Acoustic  
Leak Detector



X3301 Multispectrum  
IR Flame Detector



PointWatch Eclipse® IR  
Combustible Gas Detector



FlexVu® Universal Display  
with GT3000 Toxic Gas Detector



Eagle Quantum Premier®  
Safety System

Specifications subject to change without notice.

All trademarks are the property of their respective owners.  
© 2020 Detector Electronics Corporation. All rights reserved.

Det-Tronics manufacturing system is certified to ISO 9001—  
the world's most recognized quality management standard.



**Corporate Office**  
6901 West 110<sup>th</sup> Street  
Minneapolis, MN 55438 USA  
[www.det-tronics.com](http://www.det-tronics.com)

Phone: +1 952.941.6665  
Toll-free: +1 800.765.3473  
Fax: 952.829.8750  
[det-tronics@carrier.com](mailto:det-tronics@carrier.com)