

# Instructions

FlexVu® Explosion-Proof

Universal Display Unit

Model UD10 DCU Emulator



# Table of Contents

APPLICATION . . . . .	1	APPENDIX G — UD10-DCU WITH PIR9400 . . . . .	G-1
DESCRIPTION . . . . .	1	Wiring . . . . .	G-1
Magnetic Switches . . . . .	2	Installation Notes . . . . .	G-2
Gas Level Indication . . . . .	2	Orientation . . . . .	G-2
Special States . . . . .	2	Changing Operating Modes . . . . .	G-3
Device Enclosure . . . . .	3	Calibration . . . . .	G-3
Device Display . . . . .	3	Menu Structure . . . . .	G-3
Configuration Overview . . . . .	3	APPENDIX H — UD10-DCU WITH MODEL PIRECL . . . . .	H-1
Alarms . . . . .	4	Wiring . . . . .	H-1
Calibration Gas Concentration . . . . .	4	Orientation . . . . .	H-2
Logging . . . . .	5	Calibration . . . . .	H-3
IMPORTANT SAFETY NOTES . . . . .	5	Menu Structure . . . . .	H-4
INSTALLATION . . . . .	6	APPENDIX I — UD10-DCU WITH MODEL OPECL . . . . .	I-1
Identification of Vapor(s) to be Detected . . . . .	6	Wiring . . . . .	I-1
Identification of Detector Mounting Locations . . . . .	6	Orientation . . . . .	I-3
WIRING . . . . .	7	Calibration . . . . .	I-3
Power Supply Requirements . . . . .	7	OPECL Transmitter Lamp Fault Condition . . . . .	I-4
Wiring Cable Requirements . . . . .	7	Menu Structure . . . . .	I-4
Wiring Procedure . . . . .	7	APPENDIX J — UD10-DCU WITH NTMOS H2S SENSOR . . . . .	J-1
Shield Connections . . . . .	7	Wiring . . . . .	J-1
LON Address Switch Setting . . . . .	9	Installation Notes . . . . .	J-1
RECOMMENDED STARTUP PROCEDURE . . . . .	9	Orientation . . . . .	J-3
S <sup>3</sup> CONFIGURATION . . . . .	10	Calibration . . . . .	J-3
TROUBLESHOOTING . . . . .	15	Menu Structure . . . . .	J-4
SPECIFICATIONS . . . . .	17	APPENDIX K — UD10-DCU WITH C706X GAS SENSOR . . . . .	K-1
DEVICE REPAIR AND RETURN . . . . .	20	Wiring . . . . .	K-1
ORDERING INFORMATION . . . . .	20	Installation . . . . .	K-3
APPENDIX A — FM APPROVAL DESCRIPTION . . . . .	A-1	Calibration . . . . .	K-4
APPENDIX B — CSA CERTIFICATION DESCRIPTION . . . . .	B-1	Menu Structure . . . . .	K-4
APPENDIX C — ATEX APPROVAL DESCRIPTION . . . . .	C-1	APPENDIX L — UD10-DCU WITH MODEL CGS SENSOR . . . . .	L-1
APPENDIX D — IEC APPROVAL DESCRIPTION . . . . .	D-1	Wiring . . . . .	L-1
APPENDIX E — ADDITIONAL APPROVALS . . . . .	E-1	Important Notes . . . . .	L-1
APPENDIX F — UD10-DCU WITH GT3000 . . . . .	F-1	Installation . . . . .	L-3
Wiring . . . . .	F-1	Calibration . . . . .	L-4
Orientation . . . . .	F-2	K-Factor . . . . .	L-4
Live Maintenance . . . . .	F-2	Menu Structure . . . . .	L-4
Calibration . . . . .	F-3	APPENDIX M — UD10-DCU WITH MODEL 505/CGS . . . . .	M-1
Menu Structure . . . . .	F-4	Wiring . . . . .	M-1
		Installation . . . . .	M-2
		Orientation . . . . .	M-2
		Calibration . . . . .	M-3
		Menu Structure . . . . .	M-4
		APPENDIX N — UD10-DCU WITH GENERIC 4-20 MA SENSOR . . . . .	N-1
		Operation . . . . .	N-1
		Menu Structure . . . . .	N-1

# Table of Contents

## APPENDIX O — UD10-DCU WITH ATX10/AC100 GAS

DETECTOR .....	O-1
Wiring .....	O-1
Installation .....	O-3
Menu Structure .....	O-3

## APPENDIX P — UD10-DCU WITH MODEL PIRDUCT ... P-1

Wiring .....	P-1
Installation Notes .....	P-2
Orientation .....	P-2
Changing Operation Notes .....	P-3
Calibration .....	P-4
Menu Structure .....	P-4

## APPENDIX Q — UD10-DCU WITH MODEL PIRECL CO<sub>2</sub>

DETECTOR .....	Q-1
Wiring .....	Q-1
Orientation .....	Q-2
Calibration .....	Q-3
Menu Structure .....	Q-4

## APPENDIX R — UD10-DCU WITH LS2000 LINE OF SIGHT GAS

DETECTOR .....	R-1
Wiring .....	R-1
Installation .....	R-3
Calibration .....	R-3
Menu Structure .....	R-4

**FlexVu® Explosion-Proof  
Universal Display Unit  
Model UD10 DCU Emulator**

**IMPORTANT**

*Be sure to read and understand the entire instruction manual before installing or operating the gas detection system. This product can be used with a variety of Det-Tronics gas detectors to provide early warning of the presence of a toxic or explosive gas mixture. Proper device installation, operation, and maintenance is required to ensure safe and effective operation. If this equipment is used in a manner not specified in this manual, safety protection may be impaired.*

**APPLICATION**

The FlexVu® Model UD10 DCU Emulator (UD10-DCU) is designed for applications that require a gas detector with digital readout of detected gas levels. Its LON interface board makes the UD10-DCU compatible with Eagle Quantum Premier systems by digitizing the 4-20 mA analog signal from the attached sensor/transmitter and transmitting the value as a process variable over the LON to the EQP controller.

The UD10-DCU is designed for use with most currently available Det-Tronics gas detectors. Refer to the "Specifications" section of this manual for a list of compatible gas detectors. When furnished with the CGS interface board, the device can be used only with a CGS sensor for detection of combustible gas. The UD10/CGS combination is certified as a "Gas Detector."

Gas concentration and unit of measurement are indicated on a digital display.

All electronics are enclosed in an explosion-proof aluminum or stainless steel housing. The display unit is used with a single detector that may be either coupled directly to the UD10-DCU or remotely located using a sensor termination box.

The UD10-DCU features non-intrusive calibration. A magnet is used to perform calibration as well as to navigate the UD10-DCU's internal menu.

**DESCRIPTION**

The UD10-DCU Universal Display can be used with various 4-20 mA gas detection devices, with or without HART. The unit provides display, output, and control capabilities for the gas detector.

The UD10-DCU utilizes the following I/O:

Signal Inputs: 4-20 mA loop from the sensing device

User Inputs: Magnetic switches on the display panel  
S<sup>3</sup> Software  
HART communication

Signal Outputs: LON communication

Visible Outputs: Backlit LCD display  
Computer running S<sup>3</sup> Software

## MAGNETIC SWITCHES

Four internal magnetic switches provide a non-intrusive user interface that allows navigation through the menu. See Figure 1 for switch locations.

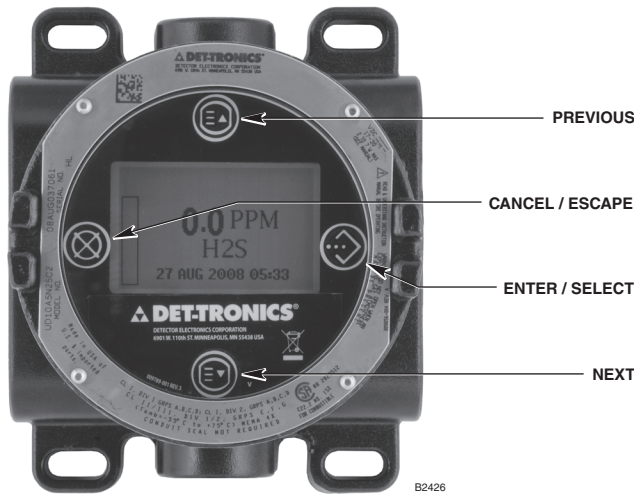

Figure 1—Faceplate of UD10-DCU

These switches are used for device configuration, checking status and event logs, and performing calibration. The switches are labeled as follows:



CANCEL / ESCAPE



ENTER / SELECT / MENU ACCESS



PREVIOUS or if on Main Screen:  
Fault Shortcut



NEXT

To actuate a magnetic switch, lightly touch the magnet to the viewing window of the UD10-DCU directly over the switch icon on the faceplate.

### CAUTION

*Handle magnets with care! Personnel wearing pacemakers/defibrillators should not handle magnets. Modern magnet materials are extremely strong magnetically and somewhat weak mechanically. Injury is possible to personnel, and magnets themselves can easily get damaged if allowed to snap towards each other, or if nearby metal objects are allowed to be attracted to the magnets.*

## NOTE

*Det-Tronics offers two magnet options for activating internal magnetic switches. While the two magnets can usually be used interchangeably, the best results will be achieved if they are used as follows: The Magnetic Tool (p/n 009700-001) is the stronger magnet and is recommended for activating the switches on the UD10-DCU viewing window. The Calibration Magnet (p/n 102740-002) is recommended for applications that involve initiating calibration or resetting the detector by touching the side of a metal junction box or detector housing (PIRECL, OPECL, etc.). Throughout this manual, the term “magnet” can refer to either device.*

## GAS LEVEL INDICATION

The UD10-DCU display will show a plus sign "+" to the right of the indicated value (i.e., 100+%LFL, 1000+PPM), to indicate an over-range. During an under-range condition, the display continues to show 0%LFL or 0PPM. Actual sensor signal / gas level can be examined using display to check the device (sensor) "PROCESS VARS" > ANALOG INPUT XX.XX mA to check an actual device output. Refer to the appropriate appendix for the attached sensor type.

## SPECIAL STATES

Special states other than warm-up, normal operation, and fault require user action for activation. These include calibration, configuration, and parameter indication / verification. See Table 1.

Table 1—Special States

STATE	Visual Display
Warm-up	"WARM UP"
Calibration	"Calibration" initially, then each calibration step
Fault	FAULT
Alarm(s)	LOW, AUX, HIGH ALARM

## Access To Menus

To access the menus, use the magnet to activate the ENTER/SELECT button. This will display the Main Menu.

The actual menu structure varies depending upon the device that is connected to the UD10-DCU. Menus for the various devices can be found in the corresponding appendix in this manual.

Some areas of the menu contain additional information, which is indicated by the presence of an arrow on that particular line. By placing the magnet to the glass over the ENTER/SELECT button, the next screen with the additional information will be shown.

The UD10-DCU automatically returns to the main screen after 10 minutes if no activity occurs.

## Quick Access/Shortcut: Fault Menu

To access the fault menu quickly, when a fault is present, touch the magnet to the glass by the PREVIOUS button.

## DEVICE ENCLOSURE

The UD10-DCU housing is a 5 port aluminum or stainless steel explosion-proof junction box with a clear viewing window.

## DEVICE DISPLAY

The UD10-DCU is provided with a 160 x 100 dot matrix backlit LCD display. See Figure 1.

During normal operation, the LCD continuously displays the detected gas level, gas type, and units of measurement. The real time clock can also be displayed if desired.

The display shows the following alarm information:

- High gas alarm
- Low gas alarm
- Aux alarm

The display indicates the following fault information:

- Device fault
- Display fault

The UD10-DCU has smart capabilities to allow easy access to the following information:

- Detector information
- Measurement range
- Alarm setpoints
- Alarm and event logs

For detailed menu structure, refer to the appropriate appendix.

## CONFIGURATION OVERVIEW

The user must select the sensor mode/type manually from the UD10-DCU display. The selection options are:

- HART Device (including Generic HART Device)
- PIR9400
- PIRDUCT
- C706x
- 505
- NTMOS
- CGS
- Generic Device

When "HART Device" is selected, the UD10-DCU communicates with the detector to determine the device type. The upper and lower range for the UD10-DCU display is determined by the detector type and must be selected before configuration data is sent from the EQP system. If the detector type or range is changed at the UD10-DCU, a configuration download from S<sup>3</sup> should again be performed.

Alarm levels and calibration gas concentration level come from the S<sup>3</sup> application. Configuration information is downloaded from S<sup>3</sup> to the controller, which sends the data to the LON interface board in the UD10-DCU. The LON interface then sends configuration information to the main processor in the UD10-DCU for storage and display. Alarm levels and calibration gas concentration cannot be set from the UD10-DCU menu system, however, they can be viewed after download.

Status information from the UD10-DCU and attached detector is passed to the EQP controller over the LON network, and then to S<sup>3</sup> for display.

## ALARMS

The UD10-DCU has a low and high alarm that are set from the S<sup>3</sup> configuration software and then downloaded to the UD10-DCU. Alarm status can be viewed at the UD10-DCU display, the EQP controller, or S<sup>3</sup>. Alarms are non-latching at the UD10-DCU, but can be latched using logic within the EQP Controller.

With some configurations, the alarm limits on the UD10-DCU are tighter than on S<sup>3</sup>. If a value is out of range, the UD10-DCU will set the value as close as possible while remaining within the allowable range (See Table 2). After the configuration download is complete, the alarm setpoints can be viewed at the UD10-DCU under Display Status->LON Config menu.



## CALIBRATION GAS CONCENTRATION

The calibration gas concentration is programmed from S3 and downloaded to the UD10-DCU. See Table 3 for calibration gas limits. NTMOS, CGS, and PIR9400

**require** a gas concentration of 50% full scale. Calibration gas concentration can be viewed from the UD10-DCU menu under Display Status->LON Config.

Table 2—UD10-DCU Alarm Limits

Detector Type	UD10-DCU Limits		Recommended EQP Configuration	EQP Limits		System Limits	
	Low Alarm	High Alarm		Low Alarm	High Alarm	Low Alarm	High Alarm
GT3000 Toxic	5-50%	10-90%	Universal Automatic	10-100%	20-100%	10-50%	20-90%
GT3000 O <sub>2</sub> *	16-20.5% v/v	5-20.5% v/v	Oxygen	1.3-25% v/v	2.5-25% v/v	16-20.5% v/v	5-20.5% v/v
PIR9400	5-50%	10-60%	Explosive	5-40%	10-60%	5-40%	10-60%
Eclipse	5-50%	10-60%	Explosive	5-40%	10-60%	5-40%	10-60%
Open Path	0.25-2.5 LFL-m	0.5-4.5 LFL-m	Universal Automatic	0.5-5 LFL-m	1-5 LFL-m	0.5-2.5 LFL-m	1-4.5 LFL-m
C706x	5-50%	10-90%	Universal Automatic	10-100%	20-100%	10-50%	20-90%
505/CGS	5-50%	10-60%	Explosive	5-40%	10-60%	5-40%	10-60%
NTMOS H <sub>2</sub> S	5-50%	10-90%	Universal Automatic	10-100%	20-100%	10-50%	20-90%
CGS	5-50%	10-60%	Explosive	5-40%	10-60%	5-40%	10-60%
Generic Device	0-100%	0-100%	Universal Automatic	10-100%	20-100%	10-100%	20-100%
PIRDUCT	5-50%	10-60%	Universal Automatic	10-100%	20-100%	10-50%	10-60%
Eclipse CO <sub>2</sub>	5-50%	10-60%	Universal Automatic	10-100%	20-100%	10-50%	10-60%
Acoustic	5-50%	10-60%	Universal Automatic	10-100%	20-100%	10-50%	10-60%
LS2000	0.5-4.5 LFL-m	0.5-4.5 LFL-m	Universal Automatic	0.5-5 LFL-m	1-5 LFL-m	0.5-4.5 LFL-m	0.5-4.5 LFL-m

\*Sensor approved for oxygen depletion (<21% V/V) only.

Table 3—Calibration Gas Concentration Limits

Detector Type	UD10-DCU Limits	Recommended EQP Configuration	EQP Limits	System Limits
GT3000 Toxic	30-90%	Universal Automatic	20-100%	30-90%
GT3000 O <sub>2</sub>	20.9% v/v	Oxygen	5-25% v/v	20.9% v/v
PIR9400	50%	Explosive	20-100%	50%
Eclipse	30-90%	Explosive	20-100%	30-90%
Open Path	1.5-4.5 LFL-m	Universal Automatic	1-5 LFL-m	1.5-4.5 LFL-m
C706x	30-90%	Universal Automatic	20-100%	30-90%
505/CGS	N/A	Explosive	20-100%	N/A
NTMOS H <sub>2</sub> S	50%	Universal Automatic	20-100%	50%
CGS	50%	Explosive	20-100%	50%
Generic Device	N/A	Universal Automatic	20-100%	20-100%
PIRDUCT	50%	Universal Automatic	20-100%	50%
Eclipse CO <sub>2</sub>	30-90%	Universal Automatic	20-100%	30-90%
Acoustic	N/A	Universal Automatic	20-100%	N/A
LS2000	1.5-4.5 LFL-m	Universal Automatic	1-5 LFL-m	1.5-4.5 LFL-m

## LOGGING

Events that can be logged in the UD10-DCU include:

- Calibration (Date, time, and success Y/N are logged for detectors that do not provide their own calibration logging capabilities.)

Faults that are logged in the UD10-DCU include:

- Detector fault
- Low power
- General fault

Alarms that are logged in the UD10-DCU for gas detector inputs include:

- High gas alarm
- Low gas alarm

The UD10-DCU can display the detector event and calibration logs (if available). Detector calibration and event logs can also be read from the detector's HART interface (where available).

The UD10-DCU has its own 1,000-entry event log available under the Display Status->History->Event Log menu.

The LON interface board in the UD10-DCU has eight alarm logs and eight calibration logs. These logs are available from the S<sup>3</sup> "Point Display Screen" for the UD10-DCU.

The EQP Controller and S<sup>3</sup> also maintain their own logs. Refer to the EQP system manual (95-8533) and/or the S<sup>3</sup> manual (95-8560) for details.

## IMPORTANT SAFETY NOTES

### CAUTION

*The wiring procedures in this manual are intended to ensure proper functioning of the device under normal conditions. However, because of the many variations in wiring codes and regulations, total compliance to these ordinances cannot be guaranteed. Be certain that all wiring complies with the NEC as well as all local codes. If in doubt, consult the authority having jurisdiction before wiring the system. Installation must be done by a properly trained person.*

### CAUTION

*This product has been tested and approved for use in hazardous areas. However, it must be properly installed and used only under the conditions specified within this manual and the specific approval certificates. Any device modification, improper installation, or use in a faulty or incomplete configuration will render warranty and product certifications invalid.*

### CAUTION

*The device contains no user serviceable components. Service or repair should never be attempted by the user. Device repair should be performed only by the manufacturer.*

### LIABILITIES

*The manufacturer's warranty for this product is void, and all liability for proper function of the detector is irrevocably transferred to the owner or operator in the event that the device is serviced or repaired by personnel not employed or authorized by Detector Electronics Corporation, or if the device is used in a manner not conforming to its intended use.*

### CAUTION

*Observe precautions for handling electrostatic sensitive devices.*

### CAUTION

*Unused conduit entries must be closed with suitably certified blanking elements upon installation.*



## INSTALLATION

### NOTE

*For complete instructions regarding wiring, installation, and use of the Eagle Quantum Premier system, refer to manual number 95-8533.*

### NOTE

*The gas detector housing must be electrically connected to earth ground. A dedicated earth ground terminal is provided on the UD10-DCU.*

The detector must always be installed per local installation codes.

Before installing the gas detector, define the following application details:

### IDENTIFICATION OF VAPOR(S) TO BE DETECTED

It is necessary to identify the vapor(s) of interest at the job site. The fire hazard properties of the vapor, such as vapor density, flashpoint, and vapor pressure should be identified and used to assist in selecting the optimum detector mounting location within the area.

For cross sensitivity information, refer to each gas detector's corresponding instruction manual. Refer to the "Specifications" section in this manual for a list of gas detectors and their corresponding instruction manuals.

### IDENTIFICATION OF DETECTOR MOUNTING LOCATIONS

Identification of the most likely leak sources and leak accumulation areas is typically the first step in identifying the best detector mounting locations. In addition, identification of air current/wind patterns within the protected area is useful in predicting gas leak dispersion behavior. This information should be used to identify optimum detector installation points.

If the vapor of interest is lighter than air, place the detector above the potential gas leak. Place the detector close to the floor for gases that are heavier than air. Note that air currents may cause a gas that is slightly heavier than air to rise under some conditions. Heated gases may also exhibit the same phenomenon.

The most effective number and placement of detectors varies depending on the conditions on site. The individual designing the installation must often rely on experience and common sense to determine the detector quantity and best locations to adequately protect the area. Note that it is typically advantageous to locate detectors where they are accessible for maintenance. Locations near excessive heat or vibration sources should be avoided.

Final suitability of possible gas detector locations should be verified by a job site survey.

The gas detector must be mounted with the sensor in the correct orientation as shown in Table 4.

If the UD10-DCU faceplate is not correctly oriented, it can be rotated at 90 degree increments by pulling the electronic module from the four mounting posts that secure it to the junction box and repositioning it as desired. Note that the module is held in place by a compression fitting – no screws are involved.

Table 4—Device Orientation

Device	Orientation
GT3000	Vertical with Sensor Pointing Down
PIR9400	Horizontal
PIRDUCT	Horizontal
PIRECL	Horizontal
PIRECL-CO <sub>2</sub>	Horizontal
OPECL	Horizontal
CGS	Vertical with Sensor Pointing Down
505/CGS	Vertical with Sensor Pointing Down
C706X	Vertical with Sensor Pointing Down
NTMOS	Vertical with Sensor Pointing Down
Acoustic	Vertical with Sensor Pointing Down
LS2000	Horizontal

## WIRING

### POWER SUPPLY REQUIREMENTS

Calculate the total gas detection system power consumption rate in watts from cold start-up. Select a power supply with adequate capability for the calculated load. Ensure that the selected power supply provides regulated and filtered 24 Vdc output power for the entire system. If a back-up power system is required, a float-type battery charging system is recommended. If an existing source of 24 Vdc power is being utilized, verify that system requirements are met. The acceptable voltage range is 18-30 Vdc measured at the input to the UD10-DCU.

### WIRING CABLE REQUIREMENTS

Always use proper cabling type and diameter for input power as well as output signal wiring. 14 to 18 AWG, 2.5–0.75 mm<sup>2</sup> shielded stranded copper wire is recommended. Correct wire size depends on the device and wire length. Refer to the appropriate appendix for additional information. The maximum cable length from power source to UD10-DCU is 2000 feet. Maximum cable length from UD10-DCU to sensor is 2000 feet.

#### NOTE

*The use of shielded cable in conduit or shielded armored cable is highly recommended. In applications where the wiring is installed in conduit, dedicated conduit is recommended. Avoid low frequency, high voltage, and non-signaling conductors to prevent nuisance EMI problems.*

#### CAUTION

*The use of proper conduit installation techniques, breathers, glands, and seals is required to prevent water ingress and/or maintain the explosion-proof rating.*

### WIRING PROCEDURE

#### NOTE

*Since the UD10-DCU can be used with a variety of different detection devices, information that is specific to each detector model (wiring, calibration, HART menus, etc.) is covered in an appendix that is dedicated to that device. Refer to the appropriate appendix at the back of this manual for specific information when wiring the detection system. For information on devices not covered in an appendix, refer to the manual provided by the device's manufacturer.*

Connect 24 Vdc power lead wires and communication network cable to the appropriate terminal block. Refer

to Figure 2 for an illustration of the UD10-DCU wiring terminal board.

COM 1 - Communication network connections:  
Connect to COM 2 terminals of the next device on the loop, A to A and B to B.

COM 2 - Communication network connections:  
Connect to COM 1 terminals of the previous device on the loop, A to A and B to B.

24 VDC - Connect the "+" terminal to the positive side of the 24 Vdc power source. (Both "+" terminals are connected internally.)

Connect the "-" terminal to the negative side of the 24 Vdc power source. (Both "-" terminals are connected internally.)

Figure 3 shows a UD10-DCU Wired to a generic sensing device. Refer to the appropriate appendix for information regarding a specific detector.

### GREASE/LUBRICATION

To ease installation and future removal, ensure that all junction box covers and sensor threads are properly lubricated. If the need arises for additional lubrication, use either Lubriplate grease (see the "Ordering Information" section for part number) or Teflon tape. Avoid the use of silicone grease.

### SHIELD CONNECTIONS

The UD10-DCU provides terminals for proper grounding of wiring cable shields (located on the sensor, 4-20 mA, and operating power terminal blocks). These shield terminals are not connected internally, but are connected to ground through capacitors. The capacitors ensure an RF ground, while preventing 50/60 Hz ground loops.

Ground all shields as shown in the wiring examples throughout this manual.

#### IMPORTANT

*For proper grounding, all junction boxes / metal enclosures must be connected to earth ground.*

The following are required for installations requiring CE Mark compliance:

- For shielded cable installed in conduit, attach the wire shields to the "shield" connections on the terminal blocks, or to earth ground on the case.
- For installations without conduit, use double shielded cable. Terminate the outer shield to earth ground on the case. Terminate the inner shield to the "shield" connection on the terminal blocks.

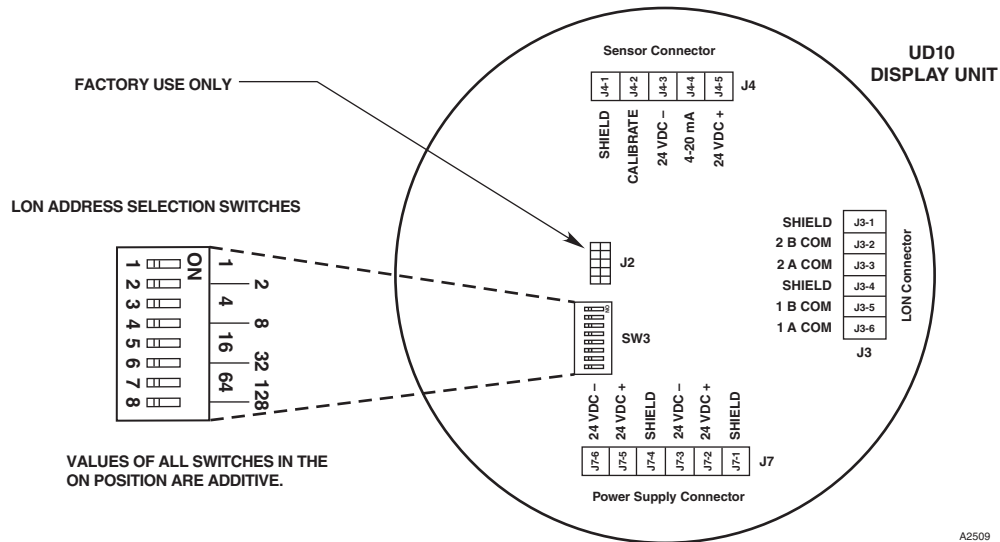

Figure 2—Wiring Terminal Board

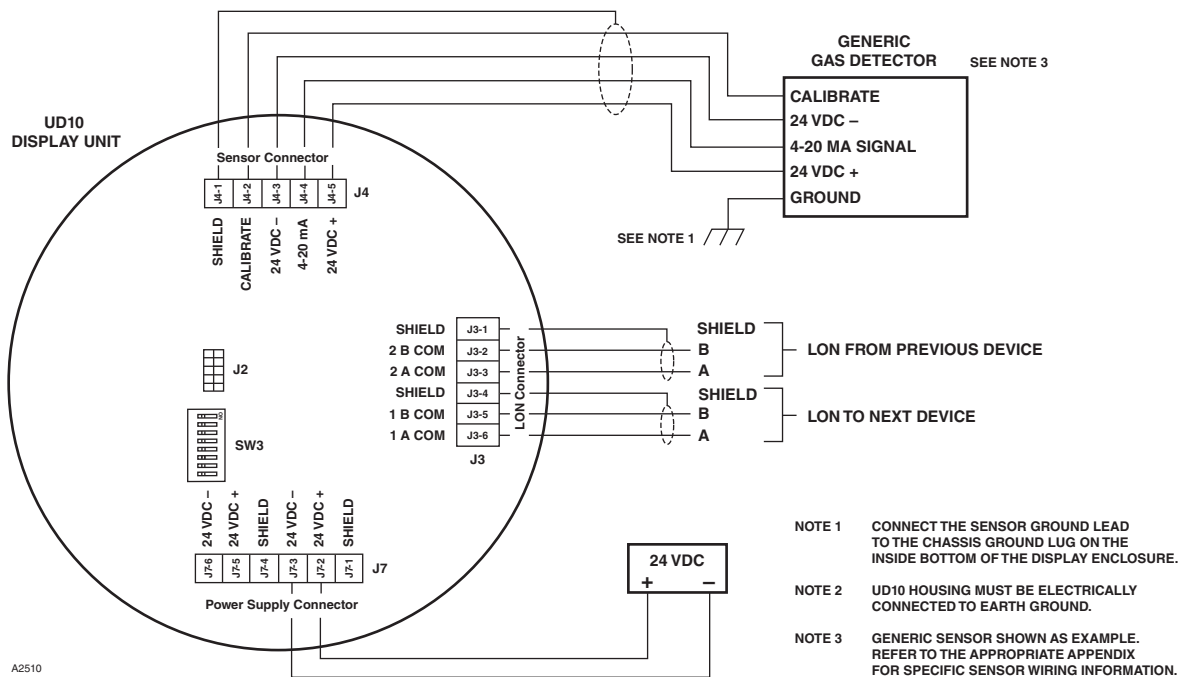

Figure 3—UD10-DCU Wired to a Generic Gas Detector

## LON ADDRESS SWITCH SETTING

Each device on the LON/SLC must be assigned a unique address. This is accomplished by setting DIP switches on the module's circuit board. See Figure 2. Each rocker switch has a specific binary value. The node address is equal to the added value of all rocker switches in the "ON" position. All "OFF" switches are ignored. The valid address range is from 5 to 250.

The switch value is read at power-up. If a change is made with power applied (not recommended), power must be cycled before the change will be recognized. The LON address can be read from the UD10-DCU menu under Display Status->LON Config.

For additional information, refer to the Eagle Quantum Premier system manual (number 95-8533).

## RECOMMENDED STARTUP PROCEDURE

1. Check the UD10-DCU LON address switches for proper setting.
2. Check all system wiring for proper connection.
3. With power applied to the system, select the correct sensor type or mode. See "Detector Type/Mode Selection Procedure" for details.

### NOTE

*A fault may be displayed until the configuration is downloaded.*

4. Note the units on the main UD10-DCU display. (This will typically be PPM or %.)
5. Record the LON address, range, and units for each detector.
6. Complete the steps in the "S<sup>3</sup> Configuration" section of this manual to configure the LON network from S<sup>3</sup>.

## DETECTOR TYPE/MODE SELECTION PROCEDURE

After power has been applied and the warm-up period is complete, select the UD10-DCU operating mode. To do this:

1. Access the Main Menu by touching the magnet to the ENTER/SELECT button. From there, navigate to the "Mode Select" menu.

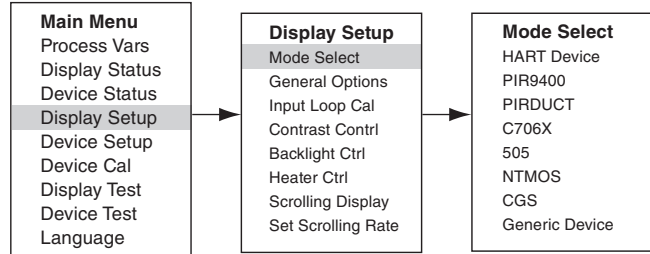

2. From the "Mode Select" menu, select and enter the appropriate operating mode based on the type of detector being used.

### NOTE

*If using a PIR9400, note that changing the gas type on the UD10-DCU does not change the gas type at the PIR9400. This change is made using a switch located in the PIR9400. Refer to the PIR9400 instruction manual (95-8440) for details.*

### NOTE

*If using a C706X detector, navigate to the "Device Setup" menu and select the appropriate gas type and unit of measurement.*

3. To exit, activate CANCEL/ESCAPE three times to return to the main display screen.

### NOTE

*If the detector is replaced with another detector type, the UD10-DCU will not recognize it until the mode is changed.*

### NOTE

*If the UD10-DCU Display is in PIR9400 mode and if:*

- a. *The connection between PIR9400 and the UD10-DCU is removed, the UD10-DCU will show a FAULT on the Gas Screen. When the connection between PIR9400 and UD10-DCU is restored, the UD10-DCU will remove the FAULT indication when current increases beyond 3.6 mA.*
- b. *Someone removes the PIR9400 & connects a HART enabled Gas Detector, it will not be recognized by the UD10-DCU Display until the mode is changed to HART.*

### S3 CONFIGURATION

Create a new DCU point with the correct LON address/  
point number. See Figure 4.

Select point type...

Device Types

InputsOutputs

- 8 Channel Analog In (EQ3710)
- 8 Channel DCIO (EQ3700)
- 8 Channel EDIO (EQ3730)
- Intelligent Protection Module (IPM)
- 8 Channel Relay Out (EQ3720)
- Agent Release Module (ARM)
- Initiating Device Circuit (IDC)
- Signal Audible Module (SAM)

Flame

- IR Flame Detector (X9800)
- MIR H2 Flame Detector (X3302)
- MIR Flame Detector (X3301)
- Automotive MIR Flame Detector (X3301)
- UV Flame Detector (EQ2200)
- UV Flame Detector (X2200)
- UVIR Flame Detector (EQ2200)
- UVIR Flame Detector (X5200)

Gas

- Digital Communication Unit (DCU)
- Point IR Gas Detector (PIRECL)
- Open Path Gas Detector(OPECL)

Power

- Power Supply Monitor (PSM)

Point Number: 6

SIL

- 8 Channel EDIO SIL
- Point IR Gas Detector (PIRECL) SIL
- MIR Flame Detector (X3301) SIL

OK Cancel

Figure 4—Point Type Selection Screen

The DCU configuration software supports six detector types:

- Explosive
- Oxygen
- Universal (Automatic Calibration)
- Universal (Manual Calibration)
- PointWatch
- DuctWatch

Table 5 shows the recommended settings for each detector type.

Table 5—Recommended Settings for each Detector Type

Detector Type	Recommended Configuration	Comments
GT3000 - All but O <sub>2</sub>	Universal Automatic	Enter the proper range for the detector. Enter PPM for units. Then select the alarm and calibration levels.
GT3000 O <sub>2</sub>	Oxygen	Units and range will automatically be set. Cal level must be set to 20.9%.
Eclipse	Explosive	Proper range and units are automatically set. Alarms are limited to approval requirements.
Open Path	Universal Automatic	Enter the proper range and units (LFL-M) for the detector.
PIR9400	Explosive	Proper range and units are automatically set. Alarms are limited to approval requirements. Calibration gas must be set to 50%.
C706x	Universal Automatic	Enter the proper range for the detector and PPM for units. Then select the alarm and calibration levels.
505	Explosive	Alarms are limited to approval requirements. Uses %LFL for units.
NTMOS	Universal Automatic	Enter the proper range (0-100) and units (PPM) for the detector. Calibration gas must be set to 50%.
CGS	Explosive	Proper range and units are automatically set. Alarms are limited to approval requirements. Calibration gas must be set to 50%.
Generic	Universal Automatic	Enter the proper range and units for the detector. Calibration is not supported, so 50% should be used as the default.
PIRDUCT	Universal Automatic	Enter the proper range (0-15) and units (%LFL). Calibration gas must be set to 50%.
Eclipse CO <sub>2</sub>	Universal Automatic	Enter the proper range and units (PPM) for the detector. Calibration gas should be set to 50%.
Acoustic	Universal Automatic	User enters the proper range and units for the detector. Calibration is not supported, so 50% should be used as the default.
LS2000	Universal Automatic	Enter the proper range (0-5) and units (LFL-M) for the detector.



Enter the appropriate data on the DCU Editor Screen. See Figure 5. The units and range entered at S<sup>3</sup> will be seen in S<sup>3</sup> and the Controller, but are not sent to the UD10-DCU. It is the user's responsibility to ensure that S<sup>3</sup> matches the actual detector type.

The alarm and calibration gas setpoints are downloaded to the UD10-DCU.

**DCU Editor...**

Tagname:

Misc:

Explosive    Oxygen

Universal (Automatic Calibration)

Universal (Manual Calibration)

Pointwatch    Ductwatch

Units:  *4 Characters max*

Range:  to

	Min	Max	
High Alarm: <input type="text"/>	2	10	
Low Alarm: <input type="text"/>	1	10	PPM
Cal Level: <input type="text"/>	2	10	
PV Deadband: <input type="text"/>		%	

Gas Mode:  ▼

Calibration Algorithm    C

Calibration Method    Automatic

Alarms    User Level    Set Defaults    OK    Cancel

Figure 5—DCU Editor Screen

The LON parameters can be checked at the UD10-DCU display under the “LON Config” menu.

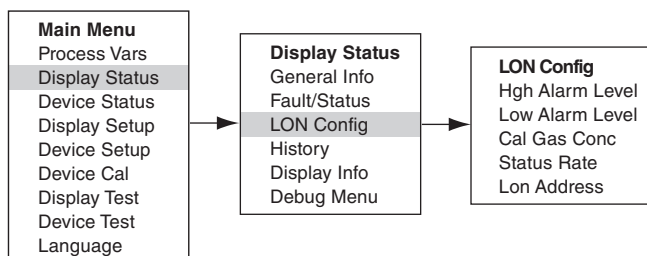

## RTC

Time and date for the UD10-DCU is automatically set by the EQP controller via the LON network. Changes to the time on the S<sup>3</sup> computer will be reflected at the UD10-DCU when the controller RTC is set.

When used with the GT3000, the RTC for the GT3000 can be synchronized to the RTC of the display by going through the Main Menu->Device Setup->RTC->“Sync W/Disp.”

## 4-20 mA INPUT LOOP CALIBRATION

If the detector connected to the UD10-DCU is HART enabled, its 4-20 mA output signal can be trimmed. (A detector calibration should be performed prior to trimming the detector output or UD10-DCU input).

### HART Detector Signal Calibration

Navigate down the menu to Device Test > D/A (Digital to Analog) Trim.

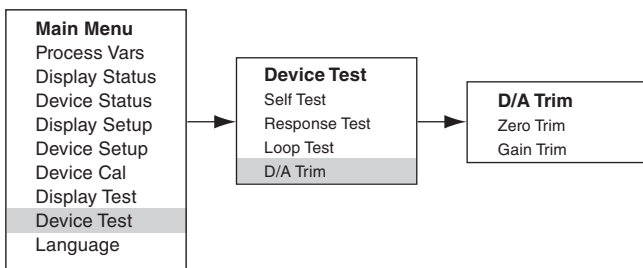

Select Zero Trim. When this screen is entered, a warning message is presented. Select ENTER to continue. When the message “Connect Reference Meter” is presented, install the current meter on the mA line between the detector and UD10-DCU. Select ENTER to continue. When the message “Set Input Current to 4 mA?” is presented, select ENTER to begin the Zero Trim function. The detector will now set its 4 mA output value. If the value indicated on the current meter is not 4.00 mA, enter the measured value into the UD10-DCU using the Previous and Next switches. The UD10-DCU calculates and corrects for the difference between the actual and entered values. When the current meter value is at the desired 4.00 mA, select ENTER to accept the new zero trim value.

Select Gain Trim. Follow the same procedure for gain/span calibration.

## UD10-DCU Input Trim

When the UD10-DCU is used with a detector that supports HART communication, an automated process can be used to trim the UD10-DCU input. Navigate down the menu to “Input Loop Cal.”

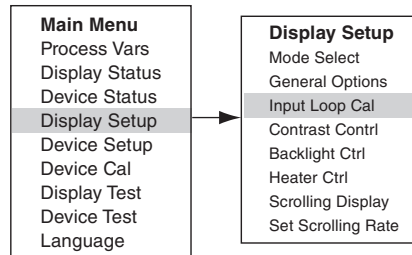

Upon entering Input Loop Cal, the UD10-DCU commands the detector to output 4 mA, and then automatically calibrates its own input. The UD10-DCU then commands the detector to output 20 mA and subsequently calibrates its own input.

If a non-HART detector is being used, the Input Loop Cal may be performed with a mA current source or loop calibrator connected to the UD10-DCU Sensor Connector. Follow the loop calibration instructions shown by the UD10-DCU for this procedure.

## OPTIONAL SYSTEM TESTS

The following tests are available for verifying proper operation of various functions of the gas detection system:

- The Self Test and Response Test are accessed from the “Display Test” screen. (A “Device Test” screen is available for performing the same tests on HART enabled detectors.)
- The Proof Test is performed by applying test gas to the sensor. It is **not** accessed from the “Display Test” screen and does **not** inhibit the outputs.

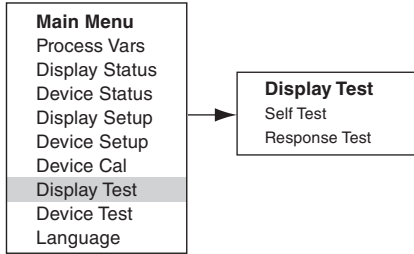

### Self-Test

This test commands the UD10-DCU to perform a fully automatic internal test. At the completion of the test, the UD10-DCU will indicate a pass or fail.

### Response Test

This test inhibits the UD10-DCU’s outputs, thereby providing a means of testing the system by applying gas to the detector without activating any alarms or affecting the output.

#### NOTE

*If the Response Test is not terminated by the operator, the test will automatically time out after ten minutes and the UD10-DCU will return to normal operation.*

### Proof Test

A Proof Test (bump test) can be performed at any time to verify proper operation and calibration of the system. Since this test does not inhibit the UD10-DCU’s outputs, secure any output devices prior to performing the test to prevent unwanted actuation.

## HISTORY

There are two separate histories, one for the display and one for the detector (if available). Both will state the number of hours that the unit has been operating and the highest and lowest recorded temperature (with time and date stamp).

## DISPLAY BACKLIGHT OPERATION

The UD10-DCU can be programmed to turn on the backlight feature of the digital display when an alarm or fault occurs or a magnetic switch is activated. Navigate to the Backlight Ctrl screen.

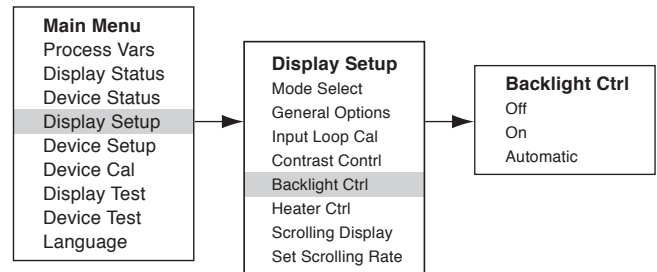

**Off** = The backlight is always off.

**On** = The backlight is always on.

**Automatic** = Normal operation – Backlight is off  
 Alarm – Backlight flashes on and off  
 Fault – Backlight is on steady  
 Magnetic Switch – Backlight is on steady

The backlight automatically turns off 10 minutes after the last Magnetic Switch activation.

If the backlight is on following a magnetic switch activation and then an alarm condition occurs, the backlight will remain on steady and not flash until the 10 minute time-out is complete. Then it will begin flashing.

## TROUBLESHOOTING

If a Fault condition is indicated on the UD10-DCU faceplate, the nature of the fault can be determined by using the magnetic tool to navigate to the appropriate Fault screen.

### NOTE

*Refer to the Menu in the appropriate appendix of this manual for the path to the proper Fault screen.*

*Shortcut: From the main display screen, touch the magnet to the “Previous” switch to go directly to the Fault screen.*

Example:

For a Display (UD10-DCU) related fault:

Main Menu > Display Status > Fault/Status > Fault

For a Device (Sensor) related fault:

Main Menu > Device Status > Fault/Status > Sensor Fault

When the active fault has been identified, refer to the Troubleshooting Tables for a description of the fault and suggested corrective action.

Refer to Table 6 for Display Faults and Table 7 for Device Faults.

Table 6—Troubleshooting Guide - Display Faults

Display Faults	Description	Recommended Action
Input Loop FLT	Fault in sensor or sensor loop	Check sensor wiring. Calibrate sensor. Ensure that sensor type matches configuration.
EE Fault	Fault in non-volatile memory	Return to factory.
ADC Ref Fault	ADC reference voltage too high or low	Return to factory.
24V Fault	Problem in 24 volt power supply or power wiring	Check power wiring and output voltage of power supply.
Flash Fault	FLASH memory Fault	Return to factory.
RAM Fault	Fault in volatile memory	Return to factory.
WDT Fault	Watchdog timer is non-functional	Return to factory.
12V Fault	12 volt internal power supply out of tolerance	Check power source. Return to factory.
5V Fault	5 volt internal power supply out of tolerance	Check power source. Return to factory.
3V Fault	3 volt internal power supply out of tolerance	Check power source. Return to factory.

Note: A fault condition will cause an oxygen detector to generate an alarm output as the decreasing 4-20 mA signal passes through the alarm range.

Table 7—Troubleshooting Guide - Device Faults

Device Faults	Description	Recommended Action
Loop Fault	Current loop below fault threshold	Check 4-20 mA loop wiring for shorts or opens.
Supply Voltage Fault	24 volt power supply voltage too low	Verify proper wiring to the device and correct voltage output from the power supply.
Calibration Fault	Bad calibration	This fault can be caused if the calibration is allowed to time out. If so, recalibrate. Ensure that there is enough gas in the calibration bottle to complete the calibration. Ensure that the gas being used for calibration is the correct type and concentration. It must match the configured setting.
Memory Fault	Self-detected memory fault	Return to factory.
ADC Fault	Self-detected ADC fault	Return to factory.
Internal Voltage Fault	Self-detected voltage fault	Check supply voltage. Return to factory.
Zero Drift	Sensor signal has drifted negative	Device may have been calibrated with background gas present. Recalibrate the detector. Purge with clean air if needed.
Temperature Sensor Fault	Temperature sensor is out of range	Return to factory.
Wrong Sensor Type	Wrong sensor type is installed	Sensor type must match configuration. Change sensor or configuration.
Lamp Fault	Open or shorted lamp	Replace lamp. Return to factory.
Alignment Fault	Open path alignment problem	Align the device as specified in the instruction manual.
Blocked Optic Fault	Optical path is blocked	Locate and remove obstruction from the optical path.
Cal Line Active	Cal line is active at start-up	Ensure that the Cal line wiring is not shorted and the switch is open.
Low Cal Line	Cal line is shorted.	Check wiring.
Sensor Fault	Self-detected fault with the sensor	Check sensor wiring. Calibrate sensor. Ensure that sensor type matches configuration.
Noise Fault*	Excessive noise on signal	Check OPECL alignment.
Align ADC Fault*	Alignment ADC saturated	Check OPECL alignment.
Align Fault*	Alignment fault	Check OPECL alignment.
Align Warning*	Alignment warning	Check OPECL alignment.
DAC Fault	DAC fault detected	Return to factory.
General Fault	Unspecified fault	Verify correct power wiring and supply voltage. Consult the factory.
High Fault	Detector output is higher than specified limit	Verify correct sensor type and calibration.
Low Fault	Detector output is lower than specified limit	Verify correct sensor type and calibration.
Dirty Optics	Detector optics are dirty	Perform the cleaning procedure as described in the detector manual, then perform calibration.
Start Cal Fault	Calibration fault	Verify correct sensor type and calibrate.

\*OPECL only.

Table 7—Troubleshooting Guide - Device Faults, Continued

Device Faults	Description	Recommended Action
EE Fault	Fault in non-volatile memory	Power may have been interrupted while the device was updating its internal data logs. Recycle power.
Ref ADC Sat	Sensor signal level is outside the range of the AD converter	Return to factory.
Active ADC Sat	Sensor signal level is outside the range of the AD converter	Return to factory.
24V Fault	Problem in 24 volt power supply or power wiring	Check power wiring and output voltage of power supply.
Flash CRC Fault	Memory fault	Return to factory.
RAM Fault	Fault in volatile memory	Return to factory.
Low Voltage	Power supply voltage outside of limits	Check power supply voltage. Return to factory.
Temp Fault	Temperature sensor fault	Return to factory.
Software Fault	Internal software fault	Return to factory.
EE Safety Fault	Internal configuration fault	Return to factory.
Gas Under Range	Sensor signal has drifted negative	Device may have been calibrated with background gas present. Recalibrate the detector. Purge with clean air if needed.
Sensor Mismatch	Wrong sensor type is installed	Sensor type must match configuration. Change sensor or configuration.
ADC CNTR Fault	Internal hardware fault	Return to factory.
3V Fault	3 volt internal power supply out of tolerance	Return to factory.
Comm Fault	Communication fault	Check detector wiring and power supply.
GEN Fault	Unspecified fault	Verify correct power wiring and supply voltage. Consult the factory.
12V Fault	12 volt internal power supply out of tolerance	Return to factory.
5V Fault	5 volt internal power supply out of tolerance	Return to factory.

## SPECIFICATIONS

### OPERATING VOLTAGE—

24 Vdc nominal, operating range is 18 to 30 Vdc.  
Ripple cannot exceed 0.5 volt P-P.

### OPERATING POWER—

Heater off: 1.3 watts nominal @ 24 Vdc with  
backlit display off.  
2 watts @ 24 Vdc with backlit display on.  
Heater on: 4 watts additional.  
CGS model: Add 4 watts with CGS interface  
board and CGS sensor installed.

Maximum power with heater and display on:  
6 watts @ 30 Vdc (Standard model)  
10 watts @ 30 Vdc (CGS model).

### NOTE

*Heater turns on when the internal temperature drops below  $-10^{\circ}\text{C}$  (default operation).*

### LON COMMUNICATION —

Digital communication, transformer isolated (78.5 kbps).

### EQP/UD10-DCU SYSTEM RESPONSE—

Toxic gas:  $T_{90} < 10$  sec.  
Combustible gas:  $T_{90} < 10$  sec.  
With CGS sensor:  $T_{90} < 12$  sec.

### SYSTEM OUTPUT ACCURACY: EQP/UD10-DCU—

The EQP/UD10-DCU adds less than 1% error to output value.

### SYSTEM OUTPUT ACCURACY: EQP/UD10-DCU—

The EQP/UD10-DCU with CGS sensor directly attached has an overall system accuracy of  $\pm 3\%$  for 0-50 LFL range and  $\pm 5\%$  for 51-100 LFL range, including error added by UD10.



Table 8—Gas Detectors Compatible with the UD10-DCU

Device	Toxic <sup>1</sup>	Catalytic Combustible	IR Combustible <sup>2</sup>	Ultrasonic Acoustic	Instruction Manual
GT3000	X				95-8616
PIR9400			X		95-8440
PIRDUCT			X		95-8573
PIRECL			X		95-8526
PIRECL CO <sub>2</sub> <sup>*</sup>	X				95-8676
OPECL			X		95-8556
CGS		X			90-1041
505/CGS		X			95-8472
C706X <sup>3</sup>	X				95-8396 95-8411 95-8414 95-8439
NTMOS <sup>**</sup>	X				95-8604
AC100/ATX10				X	95-8657
LS2000			X		95-8714

1 Hydrogen sulfide, Ammonia, Chlorine, Hydrogen, Oxygen, Carbon Monoxide, and Sulfur Dioxide.

2 Hydrocarbons, see device manual for details.

3 **C7065E Oxygen detector is not supported.**

\* Carbon dioxide only.

\*\* Hydrogen sulfide only.

**DETECTOR COMPATIBILITY—**

The UD10-DCU can be used with the Det-Tronics gas detectors listed in Table 8.

**UNIT OF MEASUREMENT—**

PPM, % LFL, % V/V, LFLM, or Mg/M<sup>3</sup>.

**OPERATING TEMPERATURE—**

-40°C to +75°C.

**STORAGE TEMPERATURE—**

-55°C to +75°C.

**HUMIDITY RANGE—**

5 to 95% RH (Det-Tronics verified).

**ELECTRO-MAGNETIC COMPATIBILITY—**

EMC Directive 2004/108/EC

EN55011 (Emissions)

EN50270 (Immunity)

**DIMENSIONS—**

See Figures 6 and 7.

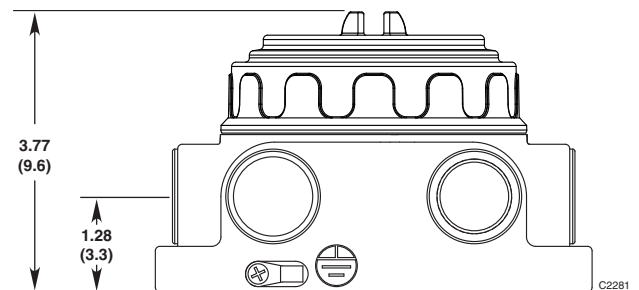
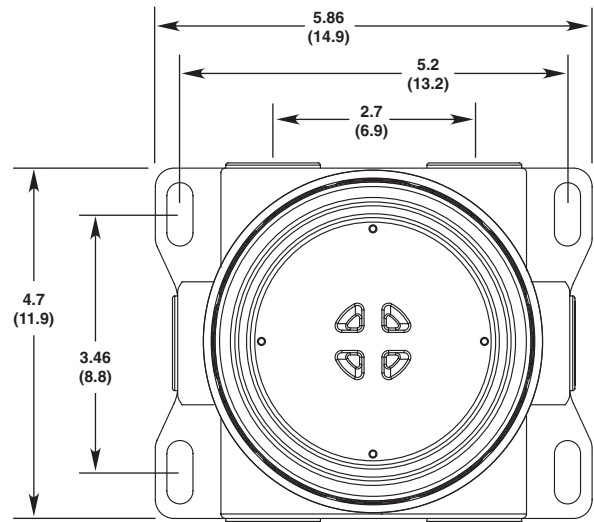

Figure 6—Dimensions of Model STB Termination Box in Inches (Centimeters)

**WIRING TERMINALS—**

14 to 18 AWG, 2.5-0.75 mm<sup>2</sup> wire can be used.

**CONDUIT ENTRIES—**

3/4" NPT or M25.

**ENCLOSURE MATERIAL—**

Epoxy coated aluminum or 316 stainless steel.

**SHIPPING WEIGHT—**

Aluminum: 4.15 pounds (1.88 kilograms).

Stainless steel: 10.5 pounds (4.76 kilograms).

**WARRANTY—**

12 months from date of installation or 18 months from date of shipment, whichever occurs first.

**CERTIFICATION—**

For complete approval details, refer to the appropriate Appendix:



Appendix A – FM

Appendix B – CSA

Appendix C – ATEX

Appendix D – IECEx

Appendix E – INMETRO

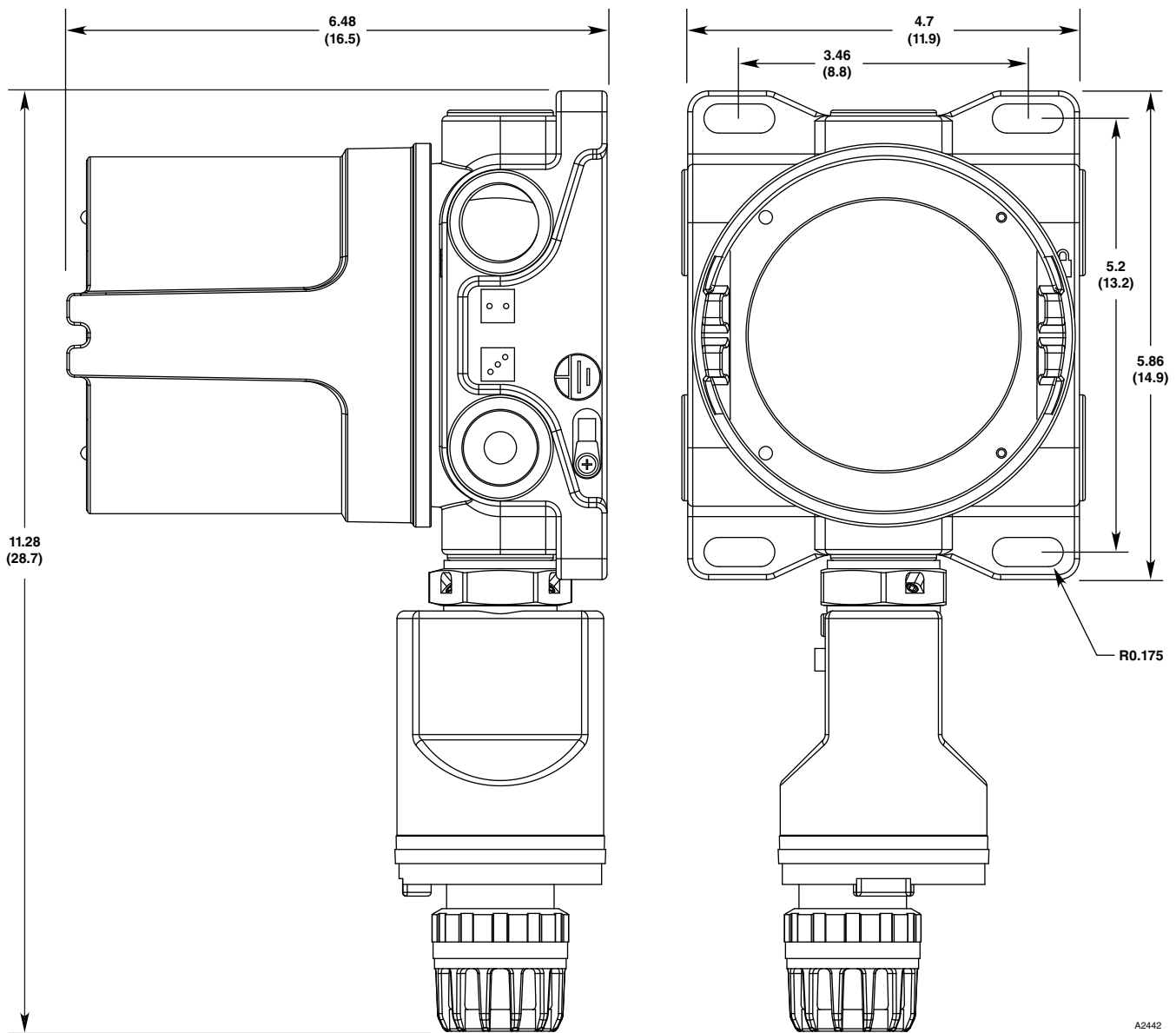

Figure 7—Dimensions of UD10-DCU with GT3000 in Inches (Centimeters)

## DEVICE REPAIR AND RETURN

Prior to returning devices, contact the nearest local Detector Electronics office so that a Return Material Identification (RMI) number can be assigned. **A written statement describing the malfunction must accompany the returned device or component to assist and expedite finding the root cause of the failure.**

Pack the unit properly. Always use sufficient packing material. Where applicable, use an antistatic bag as protection from electrostatic discharge. The RMI number should be clearly marked on the outside of the box.

### NOTE

*Inadequate packaging that ultimately causes damage to the returned device during shipment will result in a service charge to repair the damage incurred during shipment.*

Return all equipment transportation prepaid to the factory in Minneapolis.

### NOTE

*It is highly recommended that a spare be kept on hand for field replacement to ensure continuous protection.*

## ORDERING INFORMATION

Sensor module, transmitter module and termination boxes (if used) must be ordered separately.

Refer to the UD10-DCU Model Matrix for ordering details.

## REPLACEMENT PARTS

Part Number	Description
009700-001	Magnetic Tool
010535-001	Electronics Module, DCU
101197-001*	Stop Plug, 3/4" NPT, AL
101197-004*	Stop Plug, 3/4" NPT, SS
101197-005	Stop Plug, M25, AL, IP66
101197-003	Stop Plug, M25, SS, IP66
010816-001	Stop Plug, 20PK, 3/4" NPT, AL
010817-001	Stop Plug, 20PK, 3/4" NPT, SS
010818-001	Stop Plug, 20PK, M25, AL, IP66, EXDE
010819-001	Stop Plug, 20PK, M25, SS, IP66, EXDE
104190-001	Stop Plug, M25, AL, INMETRO
104190-002	Stop Plug, 3/4" NPT, AL, INMETRO
104190-003	Stop Plug, M25, SS, INMETRO
104190-004	Stop Plug, 3/4" NPT, SS, INMETRO
102804-001	Reducer, M25 to M20, AL
102804-003	Reducer, M25 to M20, SS
103922-001	475 Field Communicator
012549-001	PTFE Lubricant, 1 oz.

\*NEMA/Type 4X, IP66 rating requires addition of Teflon tape.

## UD10-DCU MODEL MATRIX

MODEL	DESCRIPTION	
UD10-DCU	Universal Display Unit	
	TYPE	MATERIAL
	A	Aluminum
	S	Stainless Steel (316)
	TYPE	THREAD TYPE
	5M	5 Port, Metric M25
	5N	5 Port, 3/4" NPT
	TYPE	OUTPUTS
	25	Relay, 4-20 mA, RS485, HART
	28	EQP / DCU Emulator
	TYPE	APPROVAL
	B	INMETRO (Brazil)
	R	VNIIFTRI (Russia)
	W	FM/CSA/ATEX/CE/IECEX
	TYPE	CLASSIFICATION (Div/Zone)
	2	Ex d (Flameproof)
	TYPE	OPTIONAL CONDITIONING BOARD
	(Blank)	None
	C	CGS
	N	NTMOS*

\*Not required for DCU Emulator model.

# APPENDIX A

## FM APPROVAL DESCRIPTION

Class I, Div. 1, Groups B, C & D T5;  
Class I, Div. 2, Groups B, C & D T4;  
Class I, Zone 1/2 AEx d IIC T5;  
Class II/III, Div. 1/2, Groups E, F & G.  
Tamb -40°C to +75°C  
NEMA/Type 4X, IP66  
Conduit seal not required.

Performance verified in accordance with:  
ANSI/ISA-92.00.01  
ANSI/ISA-12.13.01 (CGS excluded)  
FM 6310/6320  
ANSI/ISA-12.13.04/FM 6325

This approval does not include or imply approval of gas detector heads or other apparatus to which the subject instrument may be connected. In order to maintain a Factory Mutual Research approved system, the measurement input signal to which this instrument is connected must also be approved by Factory Mutual Research.

### NOTE

*Consideration must be given to overall Gas System Performance Requirements.*



### **WARNING**

*When a sensor/detector is connected directly to the UD10-DCU housing, the lower ratings of the two devices will prevail.*

## APPENDIX B

### CSA CERTIFICATION DESCRIPTION

CSA 2029512.

Class I, Div. 1, Groups B, C & D T5;

Class I, Div. 2, Groups B, C & D T4;

Class II/III, Div. 1/2, Groups E, F & G T5.

(Tamb = -40°C to +75°C)

Type 4X

Conduit seal not required.

Performance verified in accordance with:

CSA C22.2 #152.

#### NOTE

*Consideration must be given to overall Gas System Performance Requirements.*



#### **WARNING**

*When a sensor/detector is connected directly to the UD10-DCU housing, the lower ratings of the two devices will prevail.*



## APPENDIX C

### ATEX APPROVAL DESCRIPTION

Ex d IIC Gb T6  
Ta = -55°C to +75°C IP66  
(without integral CGS)

Ex d IIC Gb T5  
Ta = -40°C to +75°C IP66  
(with integral CGS or LON)

Performance verified in accordance with:  
EN 60079-29-1:2007  
EN 60079-29-4:2010

#### **Compliance with:**

EN 60079-0:2012+A11:2013  
EN 60079-1:2014

#### **Special Conditions for Safe Use ('X'):**

The UD10-DCU control unit complies with EN 60079-29-1 and/or EN 60079-29-4 only when connected to a Detector Head that also has been evaluated to EN 60079-29-1 and/or EN 60079-29-4.

Flameproof joints are not user serviceable, contact Det-Tronics service.

#### *NOTE*

*Consideration must be given to overall Gas System Performance Requirements.*

#### **WARNING**

*When a sensor/detector is connected directly to the UD10-DCU housing, the lower ratings of the two devices will prevail.*

## CATALYTIC COMBUSTIBLE GAS SENSOR (CGS)

CE 0539 II 2 G

Ex db IIC T3, T5 Gb EN60079-29-1

DEMKO 02 ATEX 131323X

T5 (Tamb = -40°C to +75°C)

T3 (Tamb = -55°C to +125°C).

EN Standards: EN 60079-0: 2012+A11: 2013

EN 60079-1: 2014

EN 60079-29 -1: 2007

### Special Conditions for Safe Use of CGS:

The CGS Combustible Gas Sensor is certified for use in following ambient temperatures:

- ambient temperature range -40°C to +75°C.

Coding: **Ex db IIC T5 Gb**

- ambient temperature range -55°C to +125°C.

Coding: **Ex db IIC T3 Gb**

The actual temperature range is marked on the sensor.

The performance ambient temperature rating is limited to -40°C to +75°C.

The CGS Combustible Gas Sensor can withstand repeated exposures to 125°C for periods up to 12 hours. It is recommended that the sensor be replaced after maximum 500 hours of exposed to the 125°C temperature condition.

The CGS Combustible Gas Sensor must be used in conjunction with the before mentioned ATEX certified Detector Electronics Corp. combustible gas detector control units for compliance with EN 60079-29-1 standards.

The CGS Combustible Gas Sensor must only be mounted into the enclosures of the Infiniti Gas Transmitter Model U9500A Series, the Combustible Gas Transmitter Model 505 Series, the Digital Communication Unit EQ 22xxDCUEX Series or the Sensor Termination Box Model STB Series.

The actual enclosure must provide a maximum measured reference pressure of 15 bar measured according to EN 60079-1: 2014, §15.

The CGS Combustible Gas Sensor is to be installed in places where there is a low risk of mechanical damage. Flameproof joints are not user serviceable; contact Det-Tronics Service.

## APPENDIX D

### IECEX APPROVAL DESCRIPTION

Ex d IIC Gb T6  
Ta = -55°C to +75°C IP66  
(without integral CGS)

Ex d IIC Gb T5  
Ta = -40°C to +75°C IP66  
(with integral CGS or LON)

Performance verified in accordance with:  
IEC 60079:29-1:2007

#### Compliance with:

IEC 60079-0:2011-06  
IEC 60079-1:2014-06

#### Special Conditions for Safe Use ('X'):

The UD10-DCU control unit complies with IEC 60079-29-1 when connected to a Detector Head with an IEC certificate of conformity to IEC 60079-29-1.

Flameproof joints are not user serviceable, contact Det-Tronics service.

#### NOTE

*Consideration must be given to overall Gas System Performance Requirements.*

#### WARNING

*When a sensor/detector is connected directly to the UD10-DCU housing, the lower ratings of the two devices will prevail.*

#### Special Conditions of Safe Use of CGS:

The CGS Combustible Gas Sensor is to be installed in places where there is a low risk of mechanical damage.

The CGS Combustible Gas Sensor is certified for use in following ambient temperatures:

Ambient temperature range -40°C to +75°C, Coding: Ex db IIC T5  
Ambient temperature range -55°C to +125°C, Coding: Ex db IIC T3  
The actual temperature range is marked on the sensor.

The CGS Combustible Gas Sensor has an ambient temperature rating for performance of -40°C to +75°C

The CGS Combustible Gas Sensor can withstand repeated exposures to 125°C for periods up to 12 hours. It is recommended that the sensor be replaced after maximum 500 hours of exposure to the 125°C temperature condition.

The CGS Combustible Gas Sensor must only be mounted into the enclosures of the Infiniti Gas Transmitter Model U9500A Series, the Combustible Gas Transmitter Model 505 Series, the Digital Communication Unit EQ 22xxDCU EX Series or the Sensor Termination Box Model STB Series.

The actual enclosure must provide a maximum measured reference pressure of 15 bar measured according to IEC 60079-1:2014, § 15.

Flameproof joints are not user serviceable; contact Det-Tronics Service.

## **APPENDIX E**

### **ADDITIONAL APPROVALS**

#### **INMETRO (Brazil)**

UL-BR 15.0469X  
Ex d IIC T5 Gb IP66  
T5 (Tamb –40°C to +75°C) With integral CGS  
– OR –

Ex d IIC T6 Gb IP66  
T6 (Tamb –55°C to +60°C) Without integral CGS

All cable entry devices shall be Brazil certified in the type of explosion protection, flameproof enclosure "d," suitable for the conditions of use and correctly installed, with an ingress protection rating of IP66.

A screw or cover lock is provided for a secondary means of fastening the cover.

#### **Specific Conditions of Use for Ex Equipment or Schedule of Limitations for Ex Components:**

The UD10 with integral CGS (Combustible Gas Sensor) is to be installed in place where there is a low risk of mechanical damage.

The CGS Combustible Gas Sensor must be mounted into the enclosure of the Infiniti Gas Transmitter Model U9500A Series, the Combustible Gas Transmitter Model 505 Series, the Digital Communication Unit EQ22xxDCU EX Series or the Sensor Termination Box Model STB Series.

# APPENDIX F

## UD10-DCU with GT3000 TOXIC GAS DETECTOR

### NOTE

For complete information regarding the GT3000 Gas Detector, refer to instruction manual 95-8616.

## WIRING

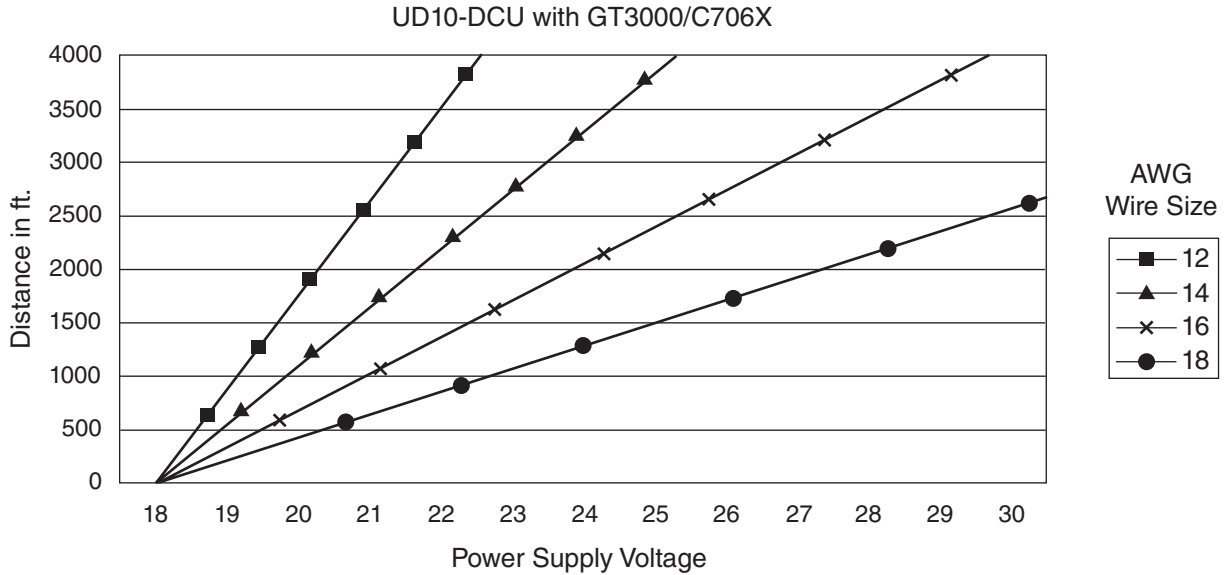

Notes: Maximum recommended cable length from power source to UD10 is 2000 feet.  
 Maximum recommended cable length from UD10 to sensor/STB termination box is 2000 feet.

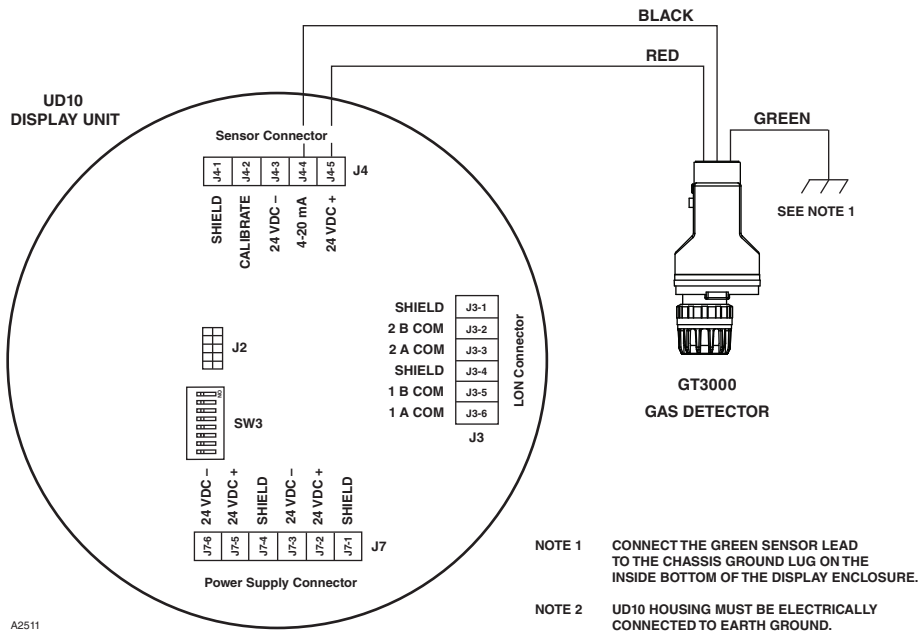

GT3000 Detector Wired Directly to UD10-DCU

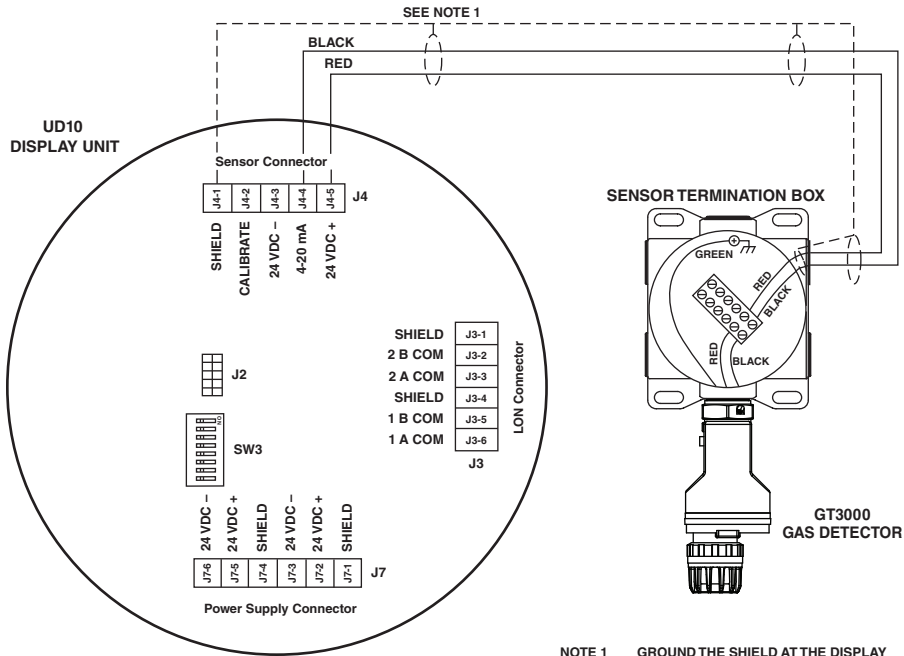

A2512

- NOTE 1 GROUND THE SHIELD AT THE DISPLAY UNIT END ONLY.
- NOTE 2 HOUSINGS MUST BE ELECTRICALLY CONNECTED TO EARTH GROUND.

UD10-DCU Wired to GT3000 Detector with Sensor Termination Box

## ORIENTATION

The device must be mounted in a vertical position only, with the GT3000 pointing down.



## LIVE MAINTENANCE

### NOTE

The sensor module on the GT3000 Gas Detector can be hot swapped, i.e., replaced without removing power or de-classifying the area. To replace a GTX Transmitter connected to the UD10-DCU with a new transmitter or a different detector type, the area **must** be de-classified.

### NOTE

Removing the sensor module with power applied will result in a fault condition until a new sensor module of the same type is installed. When replacing an oxygen sensor, this action will also result in an alarm condition as the decreasing 4-20 mA signal passes through the alarm range. Inhibit response devices to prevent unwanted actuation.

For complete information regarding sensor replacement with the GT3000 Gas Detector, refer to the GT3000 instruction manual, number 95-8616.



## CALIBRATION

### GT3000 WITH TOXIC GAS SENSOR

#### From GT3000:

1. Using the magnet, activate the magnetic calibration switch on the GT3000. The green LED turns to yellow.

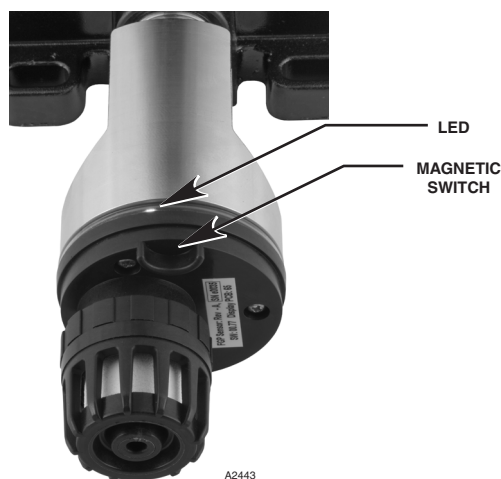

Location of Magnetic Switch on GT3000

2. The UD10-DCU will display "Waiting for Zero" on the main display screen, with the yellow LED on the detector housing illuminated continuously.
3. The UD10-DCU will then display "Waiting for Signal" on the screen, while the yellow LED on the detector is flashing.
4. The UD10-DCU will display "Waiting for Gas" on the screen, while the yellow LED on the detector is flashing.
5. Apply calibration gas to the sensor.
6. The UD10-DCU will display "Waiting for Span" on the screen, while the yellow LED on the detector is flashing.
7. When the UD10-DCU displays "Remove Cal Gas" on the screen and all LEDs on the detector housing are off, remove the calibration gas.
8. After successful calibration, the UD10-DCU automatically returns to the normal display with the green LED illuminated on the detector.

#### From UD10-DCU

1. Using the magnet to activate the switches on the UD10-DCU display, navigate to the "Calibration" menu.

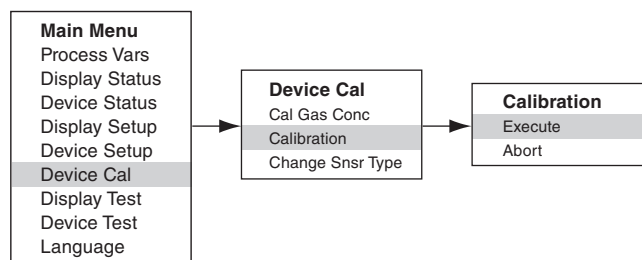

2. Activate "Execute" (Enter/Select) to start calibration.
3. The UD10-DCU will display "Waiting for Zero" on the main display screen, with the yellow LED on the detector housing illuminated continuously.
4. The UD10-DCU will then display "Waiting for Gas" on the screen, while the yellow LED on the detector is flashing.
5. Apply calibration gas to the sensor.
6. The UD10-DCU will display "Waiting for Span" on the screen, while the yellow LED on the detector is flashing.
7. When the UD10-DCU displays "Remove Cal Gas" on the screen and the LEDs on the detector housing are off, remove the calibration gas.
8. After completion of a successful calibration, the UD10-DCU automatically returns to the normal mode with the green LED illuminated on the detector.

## GT3000 WITH OXYGEN SENSOR

### From GT3000:

1. Using the magnet, activate the magnetic calibration switch on the GT3000. The green LED turns to yellow.
2. The device automatically performs the zero calibration. The yellow LED on the GT3000 is on continuously. The UD10-DCU displays "Waiting for Zero" on the main display screen.
3. When the yellow LED on the GT3000 flashes, the device automatically performs the span calculation. If using bottled 20.9% oxygen, apply immediately. The UD10-DCU displays "Waiting for Span" on the screen.
4. After successful calibration, the green LED on the GT3000 is on continuously and the UD10-DCU automatically returns to the normal display. Remove calibration gas (if used).

### From UD10-DCU

1. Using the magnet to activate the switches on the UD10-DCU display, navigate to the Calibration menu.

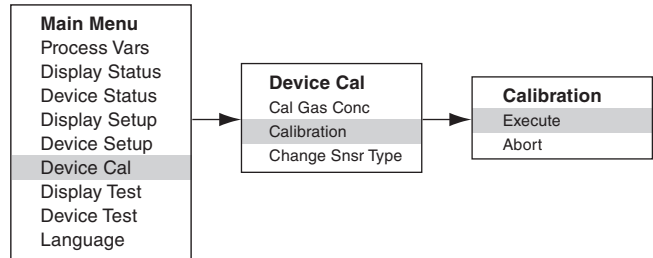

2. Activate "Execute" (Enter/Select) to start calibration.
3. The UD10-DCU will display "Waiting for Zero" on the main display screen, with the yellow LED on the detector housing illuminated continuously. The device automatically performs the zero calibration.
4. When the UD10-DCU displays "Waiting for Span" on the screen and the yellow LED on the detector is flashing, the device automatically performs the span calculation. If using bottled 20.9% oxygen, apply immediately.
5. After completion of a successful calibration, the UD10-DCU automatically returns to the normal mode with the green LED illuminated on the detector. Remove calibration gas (if used).

## MENU STRUCTURE

### UD10-DCU with GT3000 Detector

Refer to the following menu when using the UD10-DCU's LCD display and internal magnetic switches.

#### **MENU HELP**

*Status menus only allow the user to view the data.  
The Setup menus allow the user to both view and edit the data.*

# APPENDIX G

## UD10-DCU with PIR9400 POINTWATCH IR GAS DETECTOR

### NOTE

For complete information regarding the PIR9400 Gas Detector, refer to instruction manual 95-8440.

## WIRING

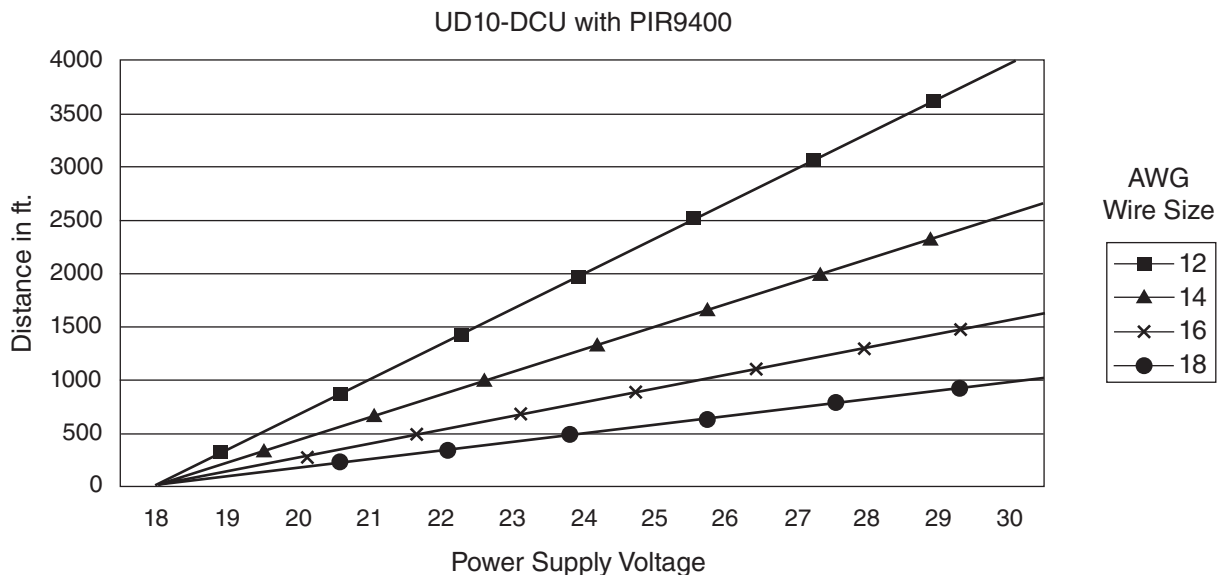

Notes: Maximum recommended cable length from power source to UD10 is 2000 feet.  
 Maximum recommended cable length from UD10 to PIR9400/PIRTB termination box is 2000 feet.

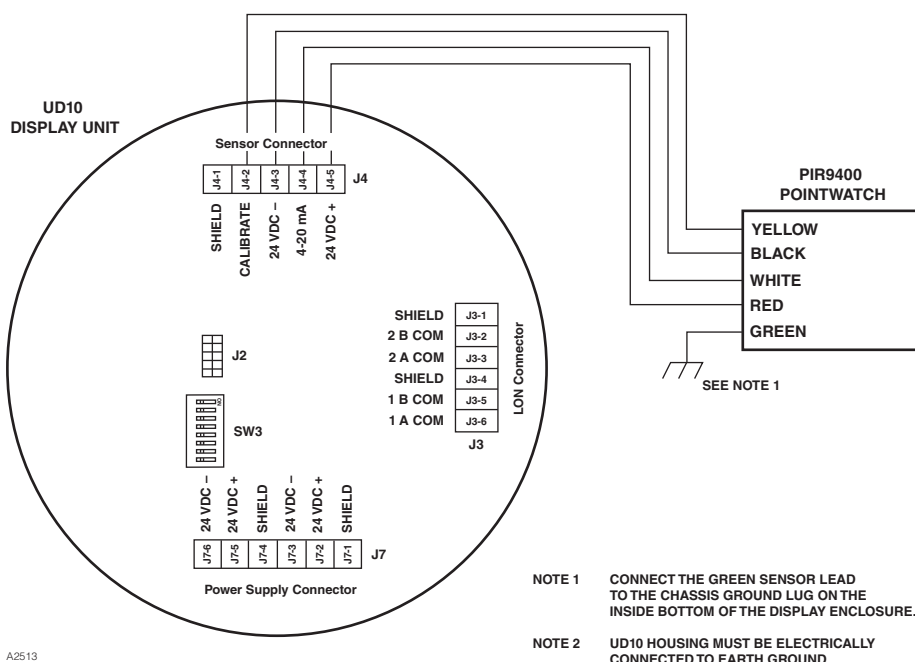

PIR9400 Wired Directly to UD10-DCU

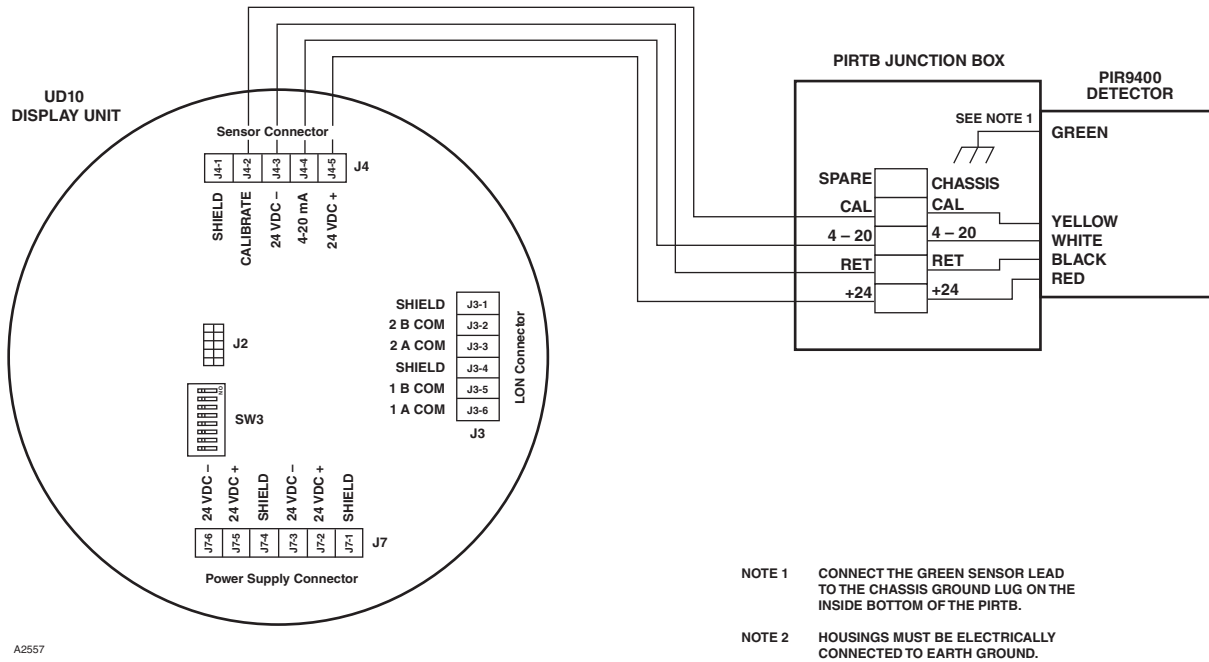

UD10-DCU Wired to PIR9400 with PIRTB Termination Box

## INSTALLATION NOTES

### IMPORTANT

Hydrocarbon-based grease emits hydrocarbon vapors that will be measured by PointWatch, resulting in inaccurate gas level readings. **Use only low vapor pressure Lubriplate grease or Teflon tape on the PointWatch detector and associated termination box.** Do not get grease on the optics of the detector. A suitable grease is listed in the "Ordering Information" section in this manual.

### IMPORTANT

In applications where both PointWatch and catalytic type sensors are used, ensure that the grease used to lubricate the PointWatch detector threads does not come into contact with the catalytic sensors, since poisoning of the catalytic sensors could result. It is strongly recommended that maintenance personnel wash their hands between handling the two types of sensors.

## ORIENTATION

It is highly recommended that the PIR9400 be installed in the horizontal position. The detector is not position-sensitive in terms of its ability to detect gas. However, the weather baffle assembly provides superior performance when installed in a horizontal position. (See illustration below).



## CHANGING OPERATING MODES

When used with a PIR9400, the operating mode of the UD10-DCU must be changed from “HART Device” to “PIR9400” mode. Refer to the “Startup” section of this manual for details.

## CALIBRATION

To initiate calibration of the PIR9400 from the UD10-DCU Display:

- Using the magnet to activate the switches on the UD10-DCU display, navigate to the “Calibration” menu.

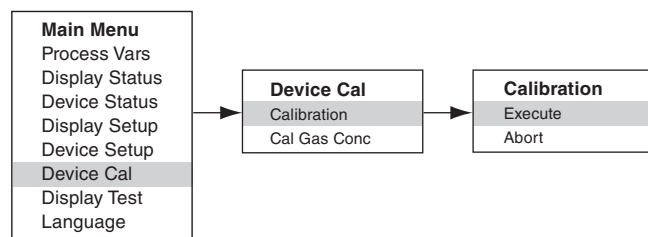

- Activate “Execute” (Enter/Select) to start calibration.
- The UD10-DCU will display “Waiting for Zero” on the main display screen.
- The UD10-DCU will then display “Waiting for Gas” on the screen.
- Apply calibration gas to the PIR9400.
- The UD10-DCU will continue to display “Waiting for Gas” on the screen.
- When the UD10-DCU displays “Remove Cal Gas” on the screen, remove the calibration gas from the PIR9400.
- The UD10-DCU automatically returns to the normal mode after successful calibration.

To initiate calibration from the PIRTB Termination Box while monitoring calibration using the UD10-DCU display:

- Using the magnet, activate the magnetic calibration switch on the PIRTB Termination Box. The LED at the PIRTB turns from off to steady red.
- The UD10-DCU will display “Waiting for Zero” on the main display screen, with a solid red LED at the PIRTB.

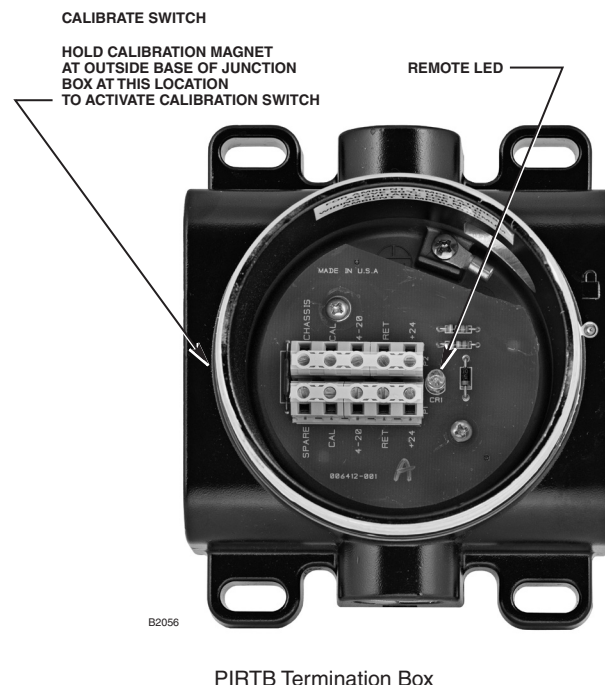

- The UD10-DCU will then display “Waiting for Gas” on the screen, while the LED at the PIRTB is flashing red.
- Apply calibration gas to the PIR9400 detector.
- The UD10-DCU will display “Waiting for Span” on the screen, with a red flashing LED at the PIRTB.
- When the UD10-DCU displays “Remove Cal Gas” on the screen and the LED at the PIRTB turns off, remove the calibration gas.
- After successful calibration, the UD10-DCU automatically returns to the normal mode, and the LED on the PIRTB remains off.

## MENU STRUCTURE

### UD10-DCU with PIR9400 PointWatch Detector

Refer to the following menu when using the UD10-DCU’s LCD display and internal magnetic switches.

#### MENU HELP

*Status menus only allow the user to view the data. The Setup menus allow the user to both view and edit the data.*

# APPENDIX H

## UD10-DCU with MODEL PIRECL

### NOTE

For complete information regarding the PIRECL Gas Detector, refer to instruction manual 95-8526.

## WIRING

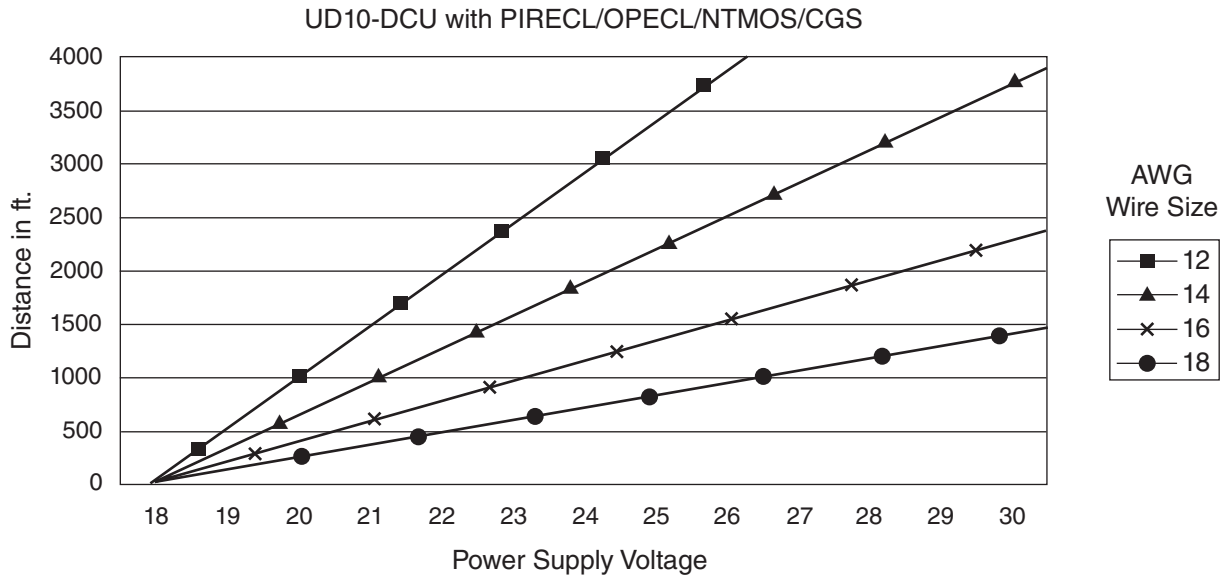

Notes: Maximum recommended cable length from power source to UD10 is 2000 feet.  
Maximum recommended cable length from UD10 to sensor/STB termination box is 2000 feet.

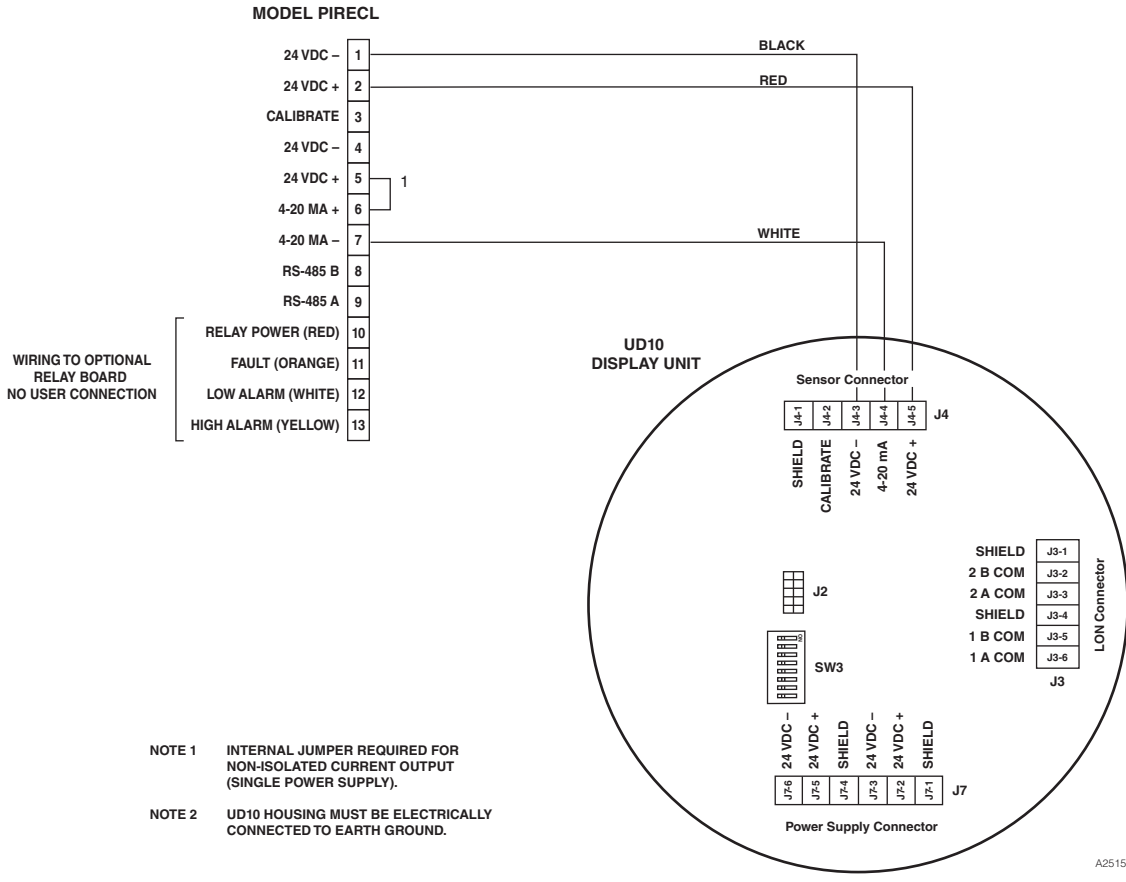

Model PIRECL Wired Directly to UD10-DCU

## ORIENTATION

It is highly recommended that the PIRECL be installed in the horizontal position. The detector is not position-sensitive in terms of its ability to detect gas. However, the weather baffle assembly provides superior performance when the PIRECL is installed with the baffle in a horizontal position.

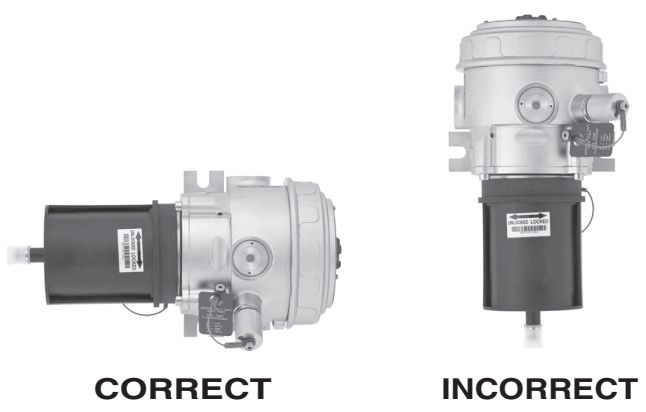

# CALIBRATION

To initiate calibration of the PIRECL from the UD10-DCU Display:

- Using the magnet to activate the switches on the UD10-DCU display, navigate to the "Calibration" menu.

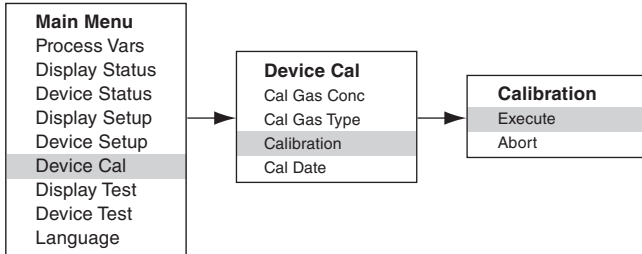

- Activate "Execute" (Enter/Select) to start calibration.
- The UD10-DCU will display "Waiting for Zero" on the main display screen, with a solid red LED on the PIRECL housing illuminated.
- The UD10-DCU will then display "Waiting for Gas" on the screen, while the LED on the PIRECL is flashing red.
- Apply calibration gas to the PIRECL
- The UD10-DCU will display "Waiting for Span" on the screen, while a red flashing LED on the PIRECL housing is illuminated.
- When the UD10-DCU displays "Remove Cal Gas" on the screen and the LED on the PIRECL housing is off, remove the calibration gas.
- After successful calibration, the UD10-DCU automatically returns to the normal display with the green LED illuminated on the PIRECL housing.

To initiate calibration from the PIRECL while monitoring calibration using the UD10-DCU display:

- Using the magnet, activate the magnetic calibration switch on the PIRECL detector. See the figure below. The LED turns from green to red.
- The UD10-DCU will display "Waiting for Zero" on the main display screen, with a solid red LED on the PIRECL housing illuminated.
- The UD10-DCU will then display "Waiting for Gas" on the screen, while the LED on the PIRECL is flashing red.
- Apply calibration gas to the PIRECL detector.
- The UD10-DCU will display "Waiting for Span" on the screen, while a red flashing LED on the PIRECL housing is illuminated.
- When the UD10-DCU displays "Remove Cal Gas" on the screen and the LED on the PIRECL housing is off, remove the calibration gas.
- After successful calibration, the UD10-DCU automatically returns to the normal mode with the green LED illuminated on the PIRECL

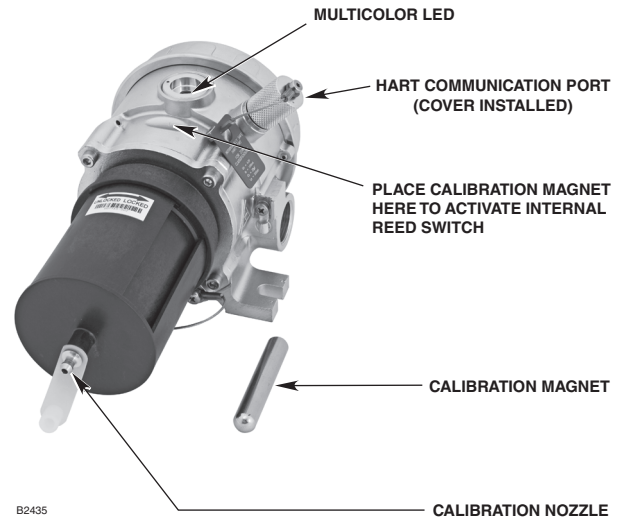

Model PIRECL Gas Detector



## **MENU STRUCTURE**

### **UD10-DCU with Model PIRECL**

Refer to the following menu when using the UD10-DCU's LCD display and internal magnetic switches.

#### ***MENU HELP***

*Status menus only allow the user to view the data.  
The Setup menus allow the user to both view and edit the data.*

# APPENDIX I

## UD10-DCU with OPEN PATH ECLIPSE MODEL OPECL

### NOTE

For complete information regarding the OPECL Gas Detector, refer to instruction manual 95-8556.

## WIRING

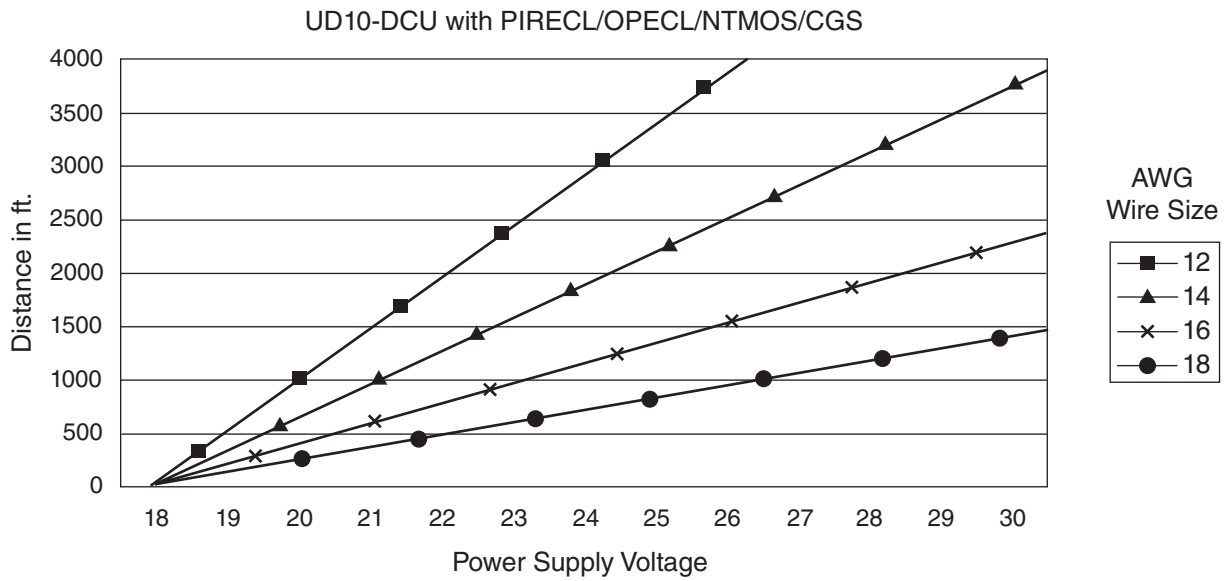

Notes: Maximum recommended cable length from power source to UD10 is 2000 feet.  
Maximum recommended cable length from UD10 to sensor/STB termination box is 2000 feet.

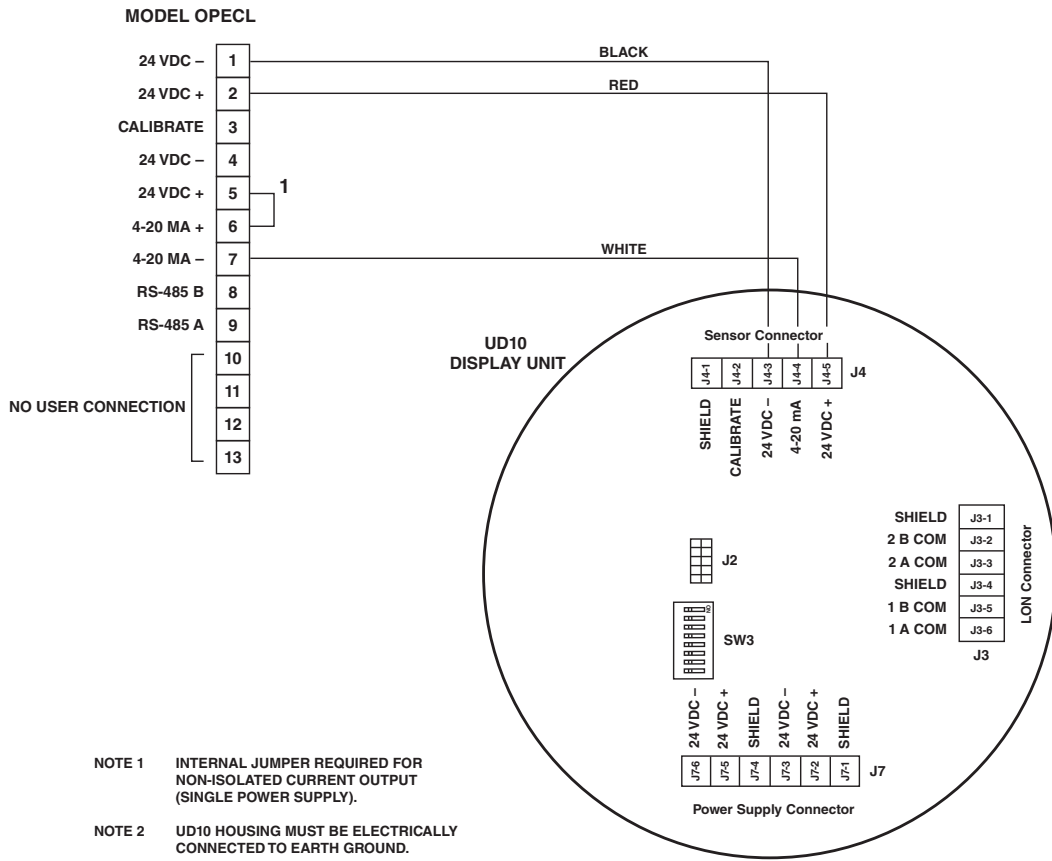

A2516

Model OPECL Wired Directly to UD10-DCU

## ORIENTATION

OPECL modules must be affixed to a solid, non-vibrating structure capable of supporting a minimum of 100 lbs (46 kg), located within the system's rated separation distance. See examples below.

In all cases, the maximum movement of the supporting structure under all anticipated operating conditions must be no more than  $\pm 0.25$  degrees. When using a vertical post, the post should be absolutely stable and without vibration. Generally, when the post is set into the ground, the portion below grade should be set in concrete at least 1 meter deep.

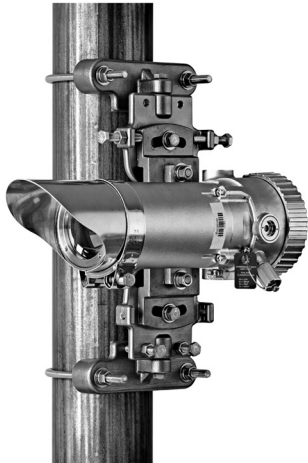

## CALIBRATION

To initiate zero calibration of the OPECL from the UD10-DCU Display:

1. Using the magnet to activate the switches on the UD10-DCU display, navigate to the "Calibration" menu.

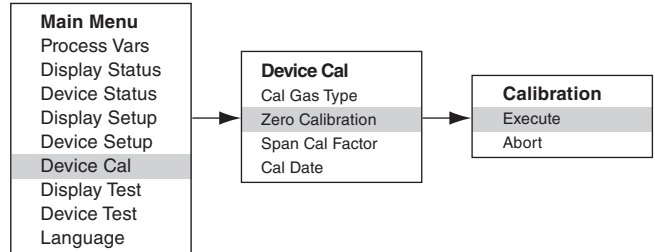

2. Activate "Execute" (Enter/Select) to start calibration.
3. The UD10-DCU will display "Waiting for Zero" on the main display screen, with a solid red LED on the OPECL housing illuminated.
4. After the calibration is successfully completed, the UD10-DCU automatically returns to the normal display with the green LED illuminated on the OPECL housing.

To initiate zero calibration from the OPECL:

1. Using the magnet, activate the magnetic calibration switch on the OPECL receiver. See the figure below. The green LED will turn red.
2. The UD10-DCU will display “Waiting for Zero” on the main display screen, with a solid red LED on the OPECL housing illuminated.
3. After the calibration is successfully completed, the UD10-DCU automatically returns to the normal display with the green LED illuminated on the OPECL housing.

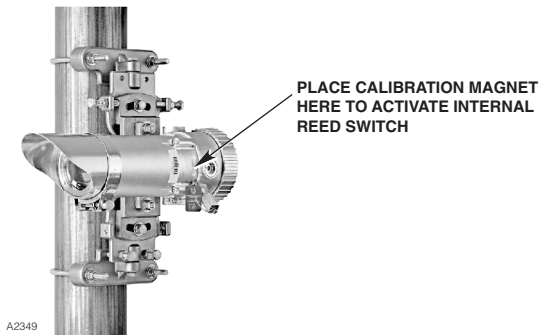

Location of Receiver’s Internal Magnetic Switch

## OPECL TRANSMITTER LAMP FAULT CONDITION

If the OPECL system experiences a Transmitter (Tx) Lamp Fault condition, the UD10-DCU display will not indicate a fault condition and its output will remain at 4 mA. The OPECL system is still fully functional and able to detect gas. If a gas alarm condition should occur, the alarm condition will override the Tx Lamp Fault condition.

The OPECL system indicates a fault condition by amber indicator LEDs on both the transmitter and the receiver.

To verify an OPECL Tx Lamp Fault condition, within the Menu Structure of the UD10-DCU Display navigate to the device Fault/Status menu:

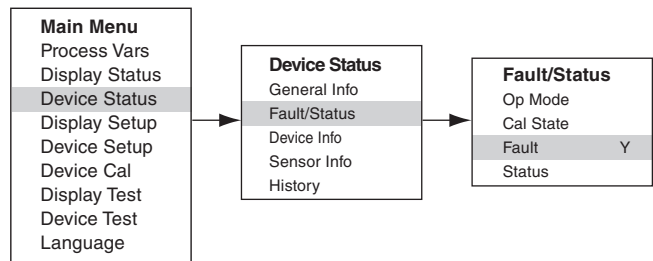

The Fault status will indicate Y (Yes). Click on “Fault” and the Fault menu will identify the fault as a “Lamp Fault”.

For complete information regarding OPECL fault indications and operation of the OPECL transmitter lamps, refer to the OPECL instruction manual, number 95-8556.

## MENU STRUCTURE

### UD10-DCU with Open Patch Eclipse Model OPECL

Refer to the following menu when using the UD10-DCU’s LCD display and internal magnetic switches.

#### MENU HELP

*Status menus only allow the user to view the data.  
The Setup menus allow the user to both view and edit the data.*

## APPENDIX J

### UD10-DCU with NTMOS H<sub>2</sub>S SENSOR

#### NOTE

For complete information regarding the NTMOS Gas Detector, refer to instruction manual 95-8604.

## WIRING

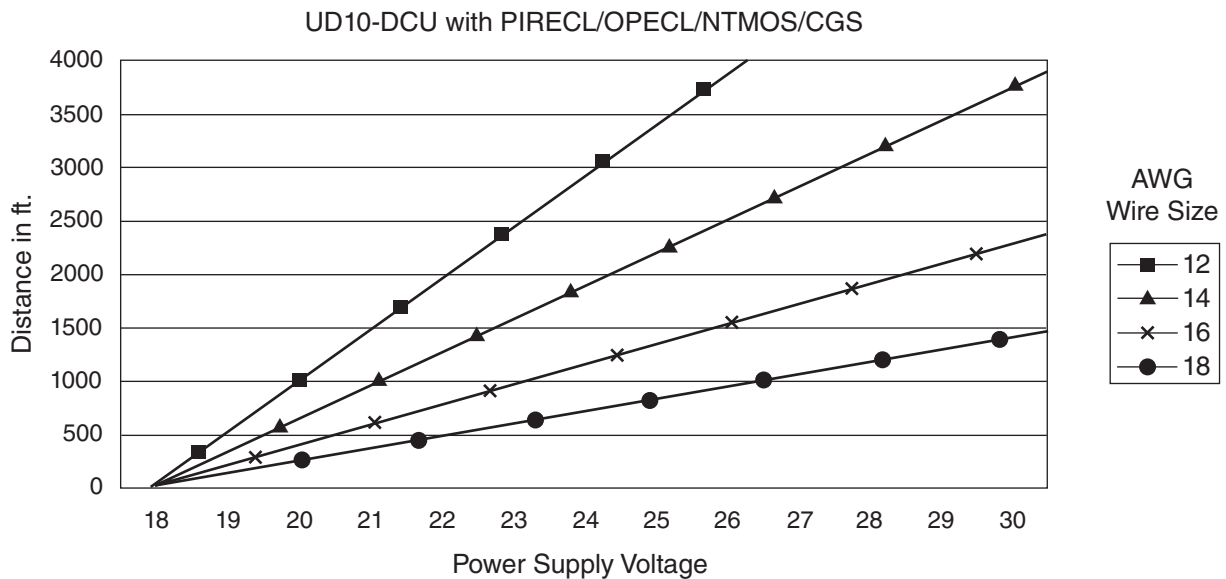

Notes: Maximum recommended cable length from power source to UD10 is 2000 feet.  
Maximum recommended cable length from UD10 to sensor/STB termination box is 2000 feet.

## INSTALLATION NOTES

#### NOTE

Never use silicone grease with the NTMOS sensor.

#### NOTE

A junction box spacer or standoff may be used to increase the distance between the device and the mounting surface, thereby facilitating installation and use of the ampoule calibrator.

#### NOTE

For non-HART applications, the NTMOS sensor can be wired to the Sensor Connector terminals (J3) on the UD10-DCU module. If HART communication will be used, the NTMOS sensor must be wired to the optional NTMOS Connector Board, located on the inside bottom of the UD10-DCU housing. Refer to the appropriate wiring diagram.

## Proper Termination of Orange and Grey Wires

The orange and grey wires on the NTMOS detector are for factory use only. Proper field termination of these wires can be accomplished in any of the following ways:

- If codes allow, they can be taped off and left unconnected.
- Connect both wires to the "Shield" terminal (J4-1).
- Connect both wires to Power Supply Minus (24 Vdc -).
- Connect to unused terminals in the STB Sensor Termination Box.

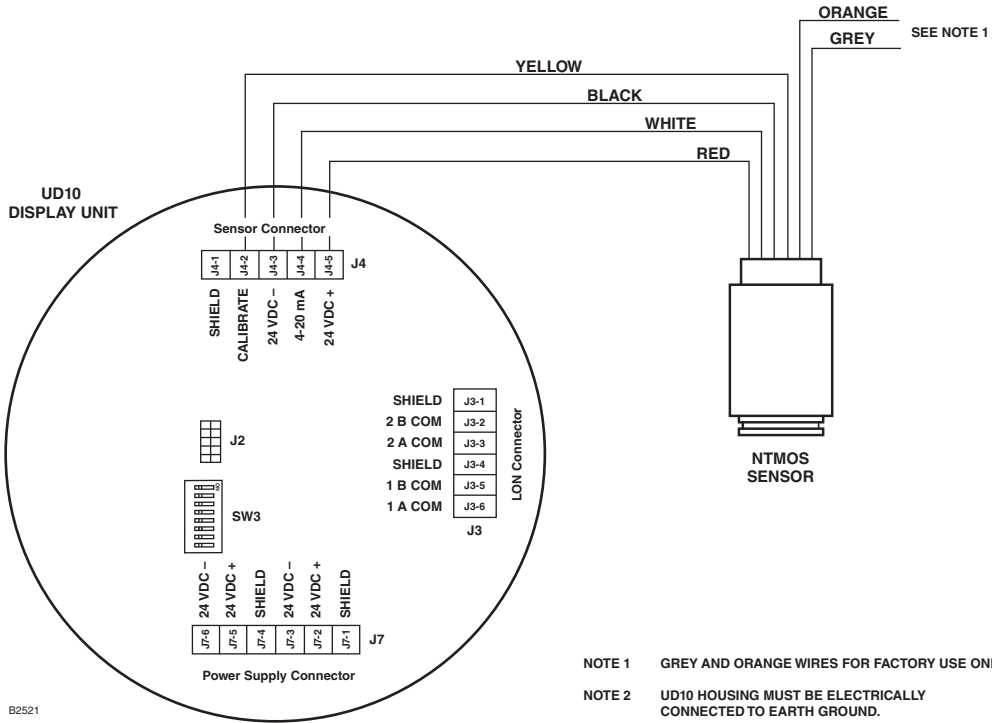

NTMOS Sensor Wired Directly to UD10-DCU

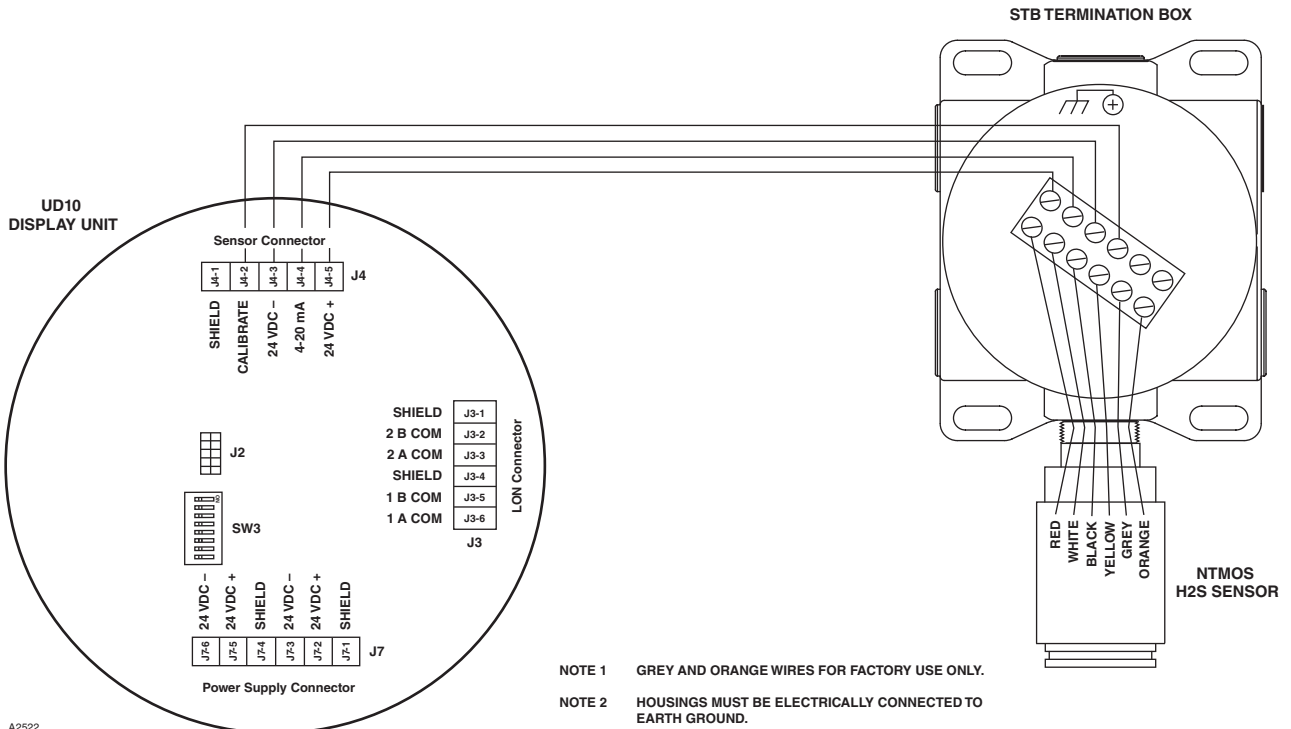

UD10-DCU Wired to NTMOS Sensor with STB Termination Box

## ORIENTATION

The UD10-DCU/NTMOS assembly must be mounted with the detector pointing down (see photo below).



- Humidification Tube Calibration Kit (p/n 010272-001) with bottled 50 ppm H<sub>2</sub>S in air (p/n 227117-014). For complete information regarding use of the Humidification Tube Calibration Kit, refer to Instruction Manual number 95-8648.

### NOTE

When calibrating with bottled 50 ppm H<sub>2</sub>S in air, the humidification tube **must** be used.

## CALIBRATION

### Calibration Notes

The NTMOS sensor must be calibrated using 50 ppm H<sub>2</sub>S in air (never use H<sub>2</sub>S in nitrogen).

Det-Tronics provides two acceptable sources of 50 ppm H<sub>2</sub>S calibration gas for use with NTMOS sensors.

### WARNING

*The use of any other H<sub>2</sub>S calibration mixture will produce inaccurate calibration results, possibly resulting in a dangerous condition if the sensor under-reports the level of H<sub>2</sub>S.*

- 50 ppm Ampoule Calibration Kit (p/n 007098-005) with 50 ppm ampoules (p/n 225741-001).

To operate the Ampoule Calibrator:

- Remove the cover and insert a 50 ppm H<sub>2</sub>S ampoule into the ampoule holder inside the calibrator. Tighten the thumb screw until snug.
- Place the cover back on the calibrator and connect it snugly to the NTMOS sensor.
- Tighten the thumb screw until the ampoule breaks.
- Rotate the mixing fan by slowly turning the mixing fan lever.

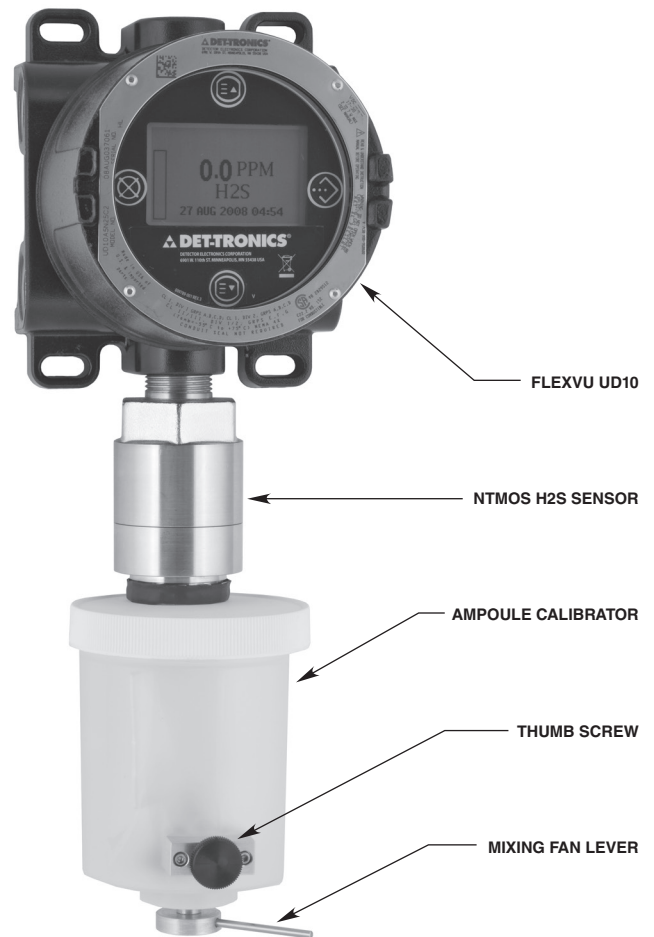

Ampoule Calibrator Attached to NTMOS Sensor





Humidification Tube Calibration Kit Attached to NTMOS Sensor

2. Activate “Execute” (Enter/Select) to begin the zero calibration.
3. The UD10-DCU will display “Waiting for Zero” on the main display screen.
4. When zero calibration is complete (approximately one minute), the UD10-DCU will display “Waiting for Span” on the main display screen.
5. Apply calibration gas to the sensor.
6. With 50 ppm H<sub>2</sub>S applied to the sensor, the UD10-DCU display will continue to show “Waiting for Span” while the span calibration is being performed.
7. When the UD10-DCU Display shows “Remove Cal Gas” the calibration is complete. Remove calibration gas from the sensor.
8. When the gas level falls below the lowest alarm setpoint, the UD10-DCU automatically exits the Calibrate mode and returns to normal operating mode.

### Calibration Procedure

To calibrate the NTMOS sensor with the FlexVu UD10-DCU Display:

1. Touch the magnet to the ENTER/SELECT button to display the Main Menu. Follow the illustration below to navigate to the “Calibrate” menu.

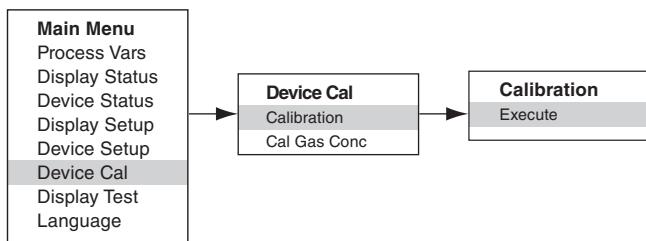

## MENU STRUCTURE

### UD10-DCU with NTMOS H<sub>2</sub>S Sensor

Refer to the following menu when using the UD10-DCU’s LCD display and internal magnetic switches.

#### MENU HELP

*Status menus only allow the user to view the data.  
The Setup menus allow the user to both view and edit the data.*

# APPENDIX K

## UD10-DCU with C706X TOXIC GAS SENSOR

### NOTE

For complete information regarding the C7064E H<sub>2</sub>S Gas Sensor, refer to instruction manual 95-8396.  
For the C7067E Chlorine Gas Sensor, refer to instruction manual 95-8439.

## WIRING

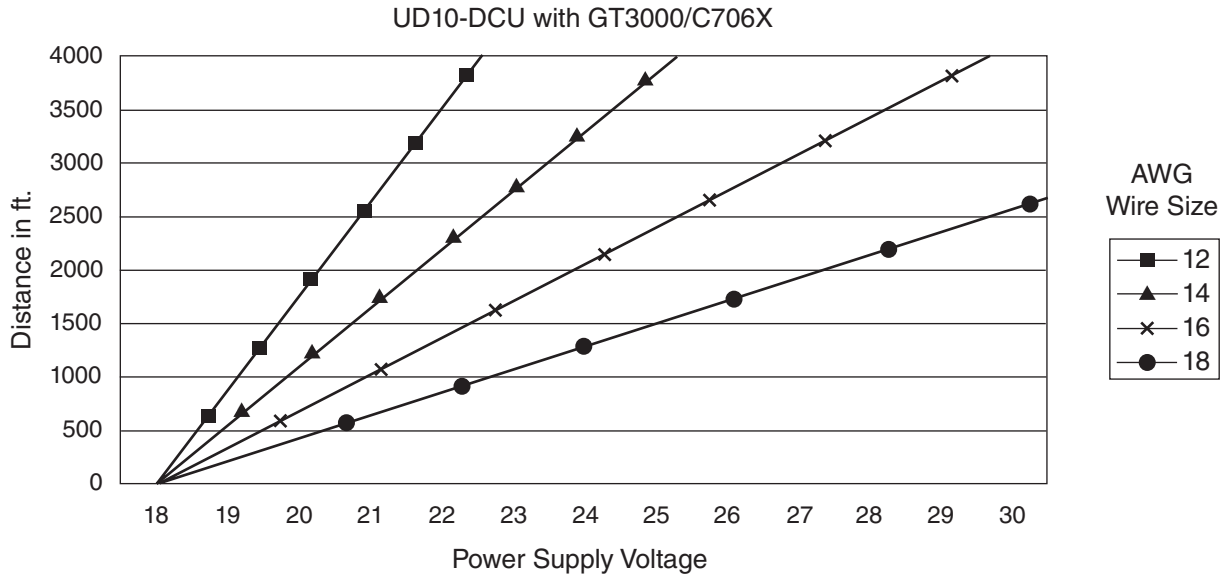

Notes: Maximum recommended cable length from power source to UD10 is 2000 feet.  
Maximum recommended cable length from UD10 to sensor/STB termination box is 2000 feet.

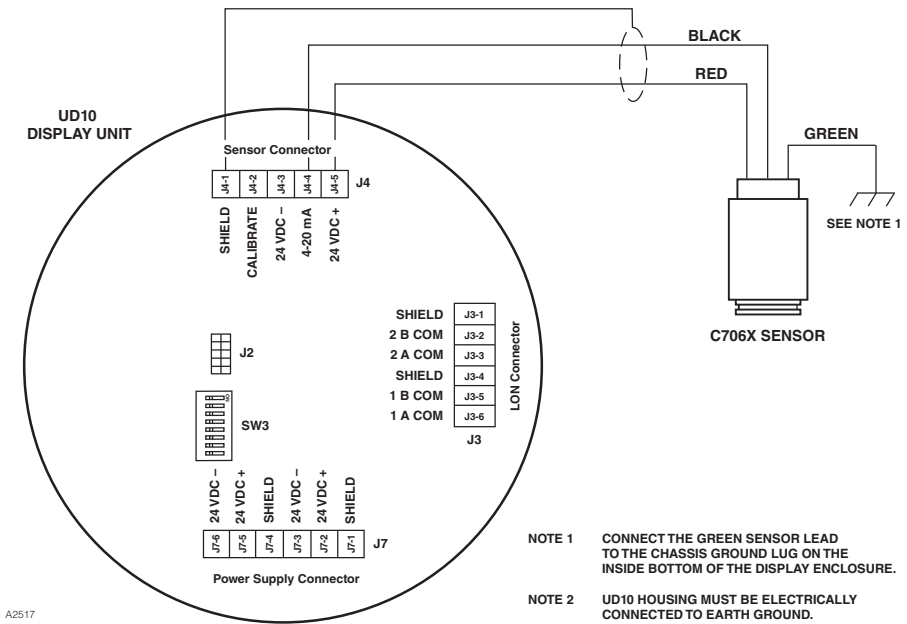

C706X Sensor Wired Directly to UD10-DCU

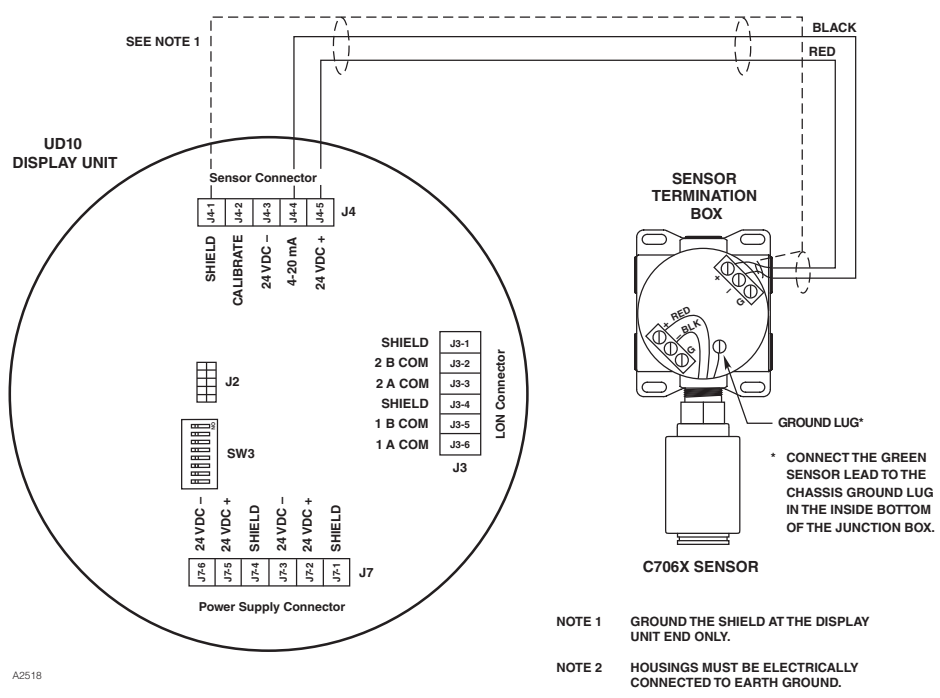

UD10-DCU Wired to C706X Sensor with STB Termination Box

## INSTALLATION

### WIRING REQUIREMENTS

The simplest installation involves installing the sensor into one of the UD10-DCU openings and connecting the wiring directly to the UD10-DCU. If the installation requires separation of the C706X sensor and the UD10-DCU Display, the sensor can be connected to a STB sensor termination box, and the C706X/STB combination wired to the UD10-DCU. In this case, shielded cable is recommended to help protect against interference caused by extraneous electrical "noise." In applications where the cable is installed in conduit, the conduit should not be used for wiring to other electrical equipment whenever possible. If other equipment power wiring is run in the same conduit, the cabling **must** be shielded. The maximum allowable distance between the C706X sensor and UD10-DCU Display Unit is limited by the resistance of the cabling used.

## INSTALLATION AND WIRING PROCEDURE

1. Determine the best mounting locations for the detectors.
2. Install the C706X sensor within the proper opening in the UD10-DCU or STB junction box. Mount the UD10-DCU/C706X with the sensor oriented vertically and the opening pointing down. The UD10-DCU should be electrically connected to earth ground.

### NOTE

*The electrochemical sensor cell does not need to be installed within the C706X housing while installing and wiring the detector/junction box. It is recommended to keep the sensor in the manufacturer's sealed shipping bag in a cool storage environment until actual power-up and calibration commissioning is performed. This will ensure that the sensor will provide maximum longevity.*

3. Terminate all three C706X conductors at the proper terminals. Refer to the appropriate illustration for details.
4. Double check that all wiring is the proper size and type and has been installed correctly. Check operating voltage at the C706X sensor and the UD10-DCU Display Unit.

### NOTE

*Do not apply power to the system with the junction box cover removed unless the area has been de-classified.*

5. Proceed with startup and calibration.

## CALIBRATION

To initiate calibration of the C706X sensor from the UD10-DCU Display:

1. Using the magnet to activate the switches on the UD10-DCU display, navigate to the "Calibrate" menu.

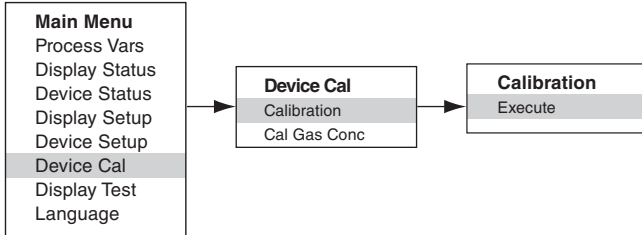

2. Activate "Execute" (Enter/Select) to start calibration.
3. The UD10-DCU will display "Waiting for Zero" on the main display screen as it performs zero calibration.
4. When zero calibration is complete, the UD10-DCU will display "Waiting for Gas" on the screen.
5. Apply calibration gas to the sensor.
6. The UD10-DCU will display "Waiting for Span" on the screen while the span calibration is being performed.
7. When the UD10-DCU displays "Remove Cal Gas" on the screen, remove the calibration gas from the sensor.
8. When calibration is complete, "Remove Cal Gas" is no longer displayed on the screen and the UD10-DCU automatically returns to the normal operating mode.

## MENU STRUCTURE

### UD10-DCU with C706X Series Sensor

Refer to the following menu when using the UD10-DCU's LCD display and internal magnetic switches.

#### MENU HELP

*Status menus only allow the user to view the data.  
The Setup menus allow the user to both view and edit the data.*

# APPENDIX L

## UD10-DCU with MODEL CGS COMBUSTIBLE GAS SENSOR

### WIRING

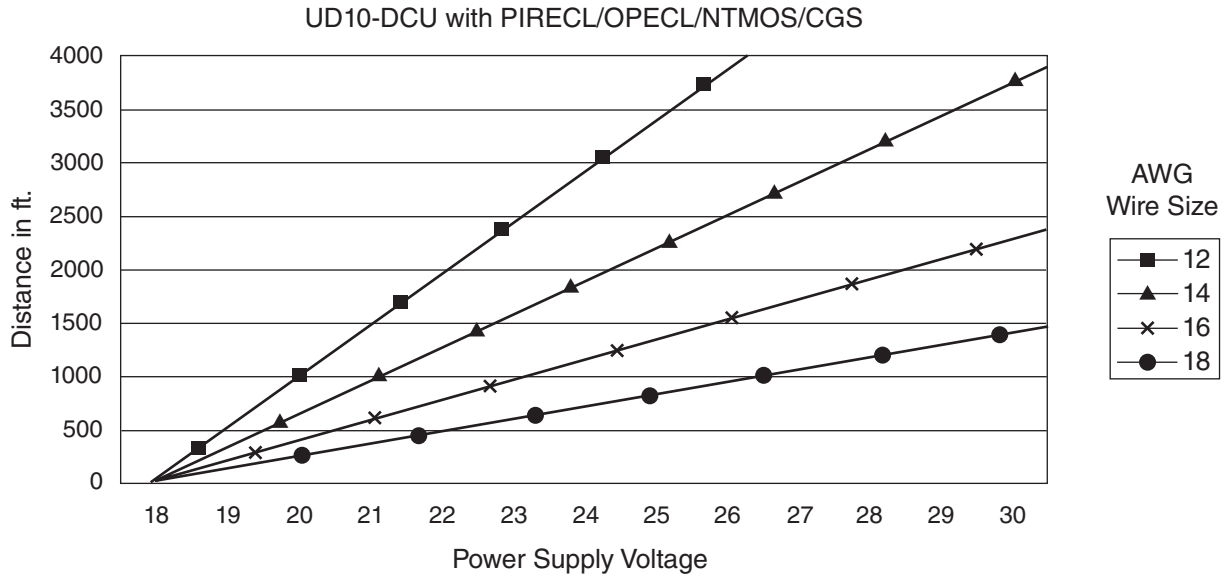

Notes: Maximum recommended cable length from power source to UD10 is 2000 feet.  
Maximum recommended cable length from UD10 to CGS sensor is 500 feet  
(using 16 AWG, 1.5 mm<sup>2</sup> cable minimum).

### IMPORTANT NOTES

#### NOTE

The UD10-DCU with CGS Interface option and CGS sensor is certified as a "Gas Detector" and performance approved to standards FM6310/6320, ATEX 60079-29-1, and IEC 60079-29-1.

#### NOTE

Only Constant Current type CGS sensors may be used with the UD10-DCU.

#### **⚠ CAUTION**

The sintered metal flame arrestor is an integral part of the combustible gas sensor. DO NOT operate the gas detector if the flame arrestor is damaged or missing, since the exposed element is a potential ignition source.

#### **⚠ CAUTION**

Silicone based lubricants must never be used on or near the CGS sensor, since this can result in irreversible damage to the sensing element.

#### **⚠ CAUTION**

When the UD10-DCU is configured for a non-latching high alarm, the EQP Controller must always latch and require a deliberate manual action to clear a high gas alarm.

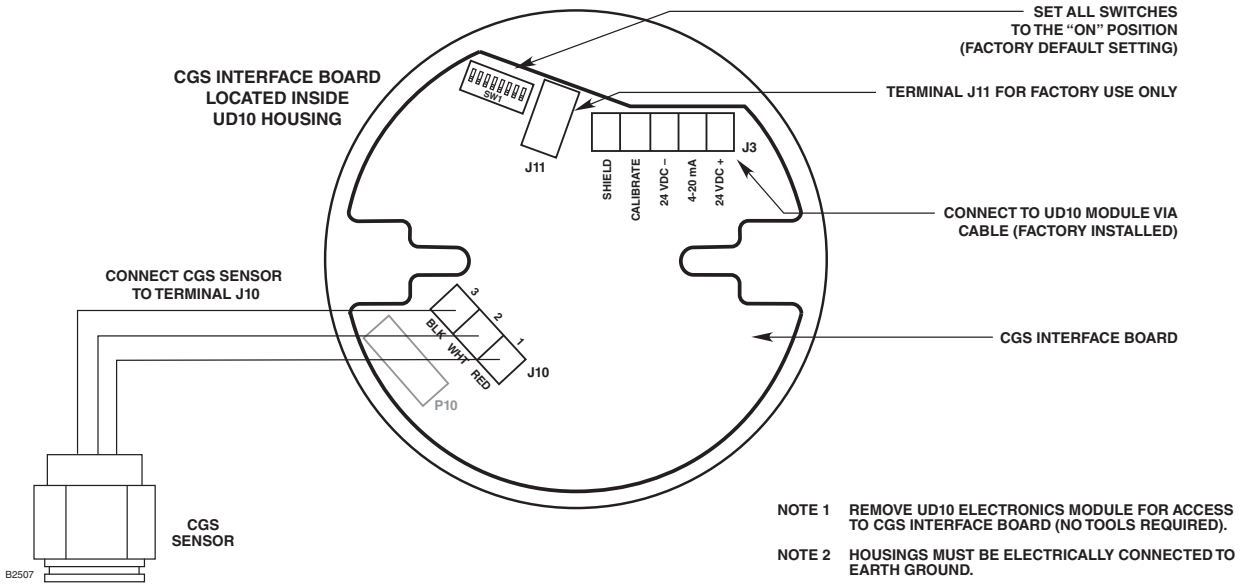

CGS Sensor Wired Directly to UD10-DCU

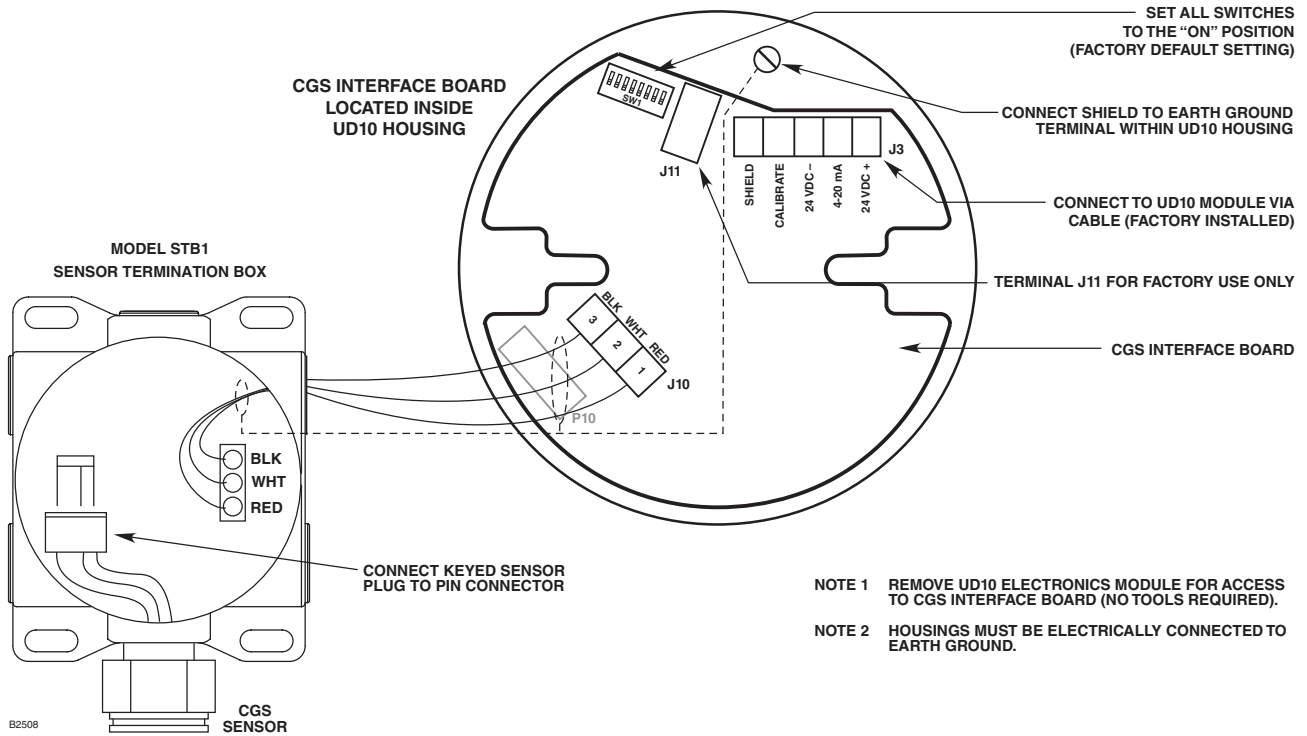

UD10-DCU Wired to CGS Sensor with STB Termination Box

## INSTALLATION

### WIRING REQUIREMENTS

The simplest installation involves installing the sensor into one of the UD10-DCU openings and connecting the wiring directly to the CGS interface board.

#### Sensor Separation

If the installation requires separation of the CGS sensor and the UD10-DCU Display, the sensor can be connected to a model STB1 sensor termination box, and the CGS/STB combination wired to the UD10-DCU.

In this case, shielded cable is recommended to help protect against interference caused by extraneous electrical “noise.”

In applications where the cable is installed in conduit, the conduit should not be used for wiring to other electrical equipment whenever possible. If other equipment power wiring is run in the same conduit, the cabling **must** be shielded.

The maximum allowable distance between the CGS sensor and UD10-DCU Display Unit is 500 feet, with connecting cable 16 AWG, 1.5 mm<sup>2</sup> minimum.

### INSTALLATION AND WIRING PROCEDURE

1. Determine the best mounting locations for the detectors.
2. Install the CGS sensor within the proper opening in the UD10-DCU or STB junction box. Mount the device with the sensor oriented vertically and the opening pointing down. All junction boxes should be electrically connected to earth ground.
3. Terminate all wiring at the proper terminals. Refer to the appropriate illustration for details.
4. Double check that all wiring is the proper size and type and has been installed correctly. Check for correct operating voltage at the device.

#### NOTE

*Do not apply power to the system with the junction box cover removed unless the area has been de-classified.*

5. Proceed with startup and calibration.

## CALIBRATION

#### NOTE

*For maximum calibration accuracy, allow a new sensor to operate under power for several hours (minimum one hour) to ensure a stable output before performing calibration. For the highest degree of accuracy, perform a second calibration after 24 hours.*

To initiate calibration of the CGS sensor from the UD10-DCU Display:

1. Using the magnet to activate the switches on the UD10-DCU display, navigate to the “Calibrate” menu.

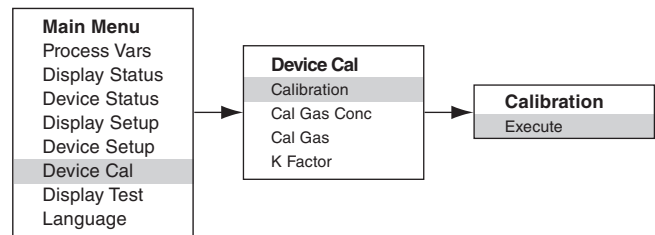

2. Activate “Execute” (Enter/Select) to start calibration.
3. The UD10-DCU will display “Waiting for Zero” on the main display screen as it performs zero calibration.
4. When zero calibration is complete, the UD10-DCU will display “Waiting for Gas” on the screen.
5. Apply calibration gas to the sensor.
6. The UD10-DCU will display “Waiting for Span” on the screen while the span calibration is being performed.
7. When the UD10-DCU shows “Remove Cal Gas” on the screen, remove the calibration gas from the sensor.
8. The UD10-DCU automatically exits the Calibrate mode and returns to normal operating mode upon completion of a successful calibration.



## Determining Sensor Life Remaining

At the time of calibration, the UD10-DCU logs the sensor mV signal. This value can be used for determining the approximate sensor life remaining.

To view all the recorded mV signal values for the sensor, from the Main Menu, navigate to:

Device Status > Calibration Log > Span.

To view the mV signal from the most recent calibration only, from the Main Menu, navigate to:

Device Status > Device Info > Response.

A typical new sensor reads between 45 and 55 mV.

- At 21-55 mV, "Cal OK" is recorded in the Cal Log, along with the Span value.
- At 15-20 mV, "Cal OK" is recorded in the Cal Log, along with the Span value. In addition, "Weak Sensor" is shown on the UD10-DCU display for about 20 seconds. After 20 seconds, the "Weak Sensor" message is no longer seen, but a "Weak Sensor" status is recorded (Device Status > Fault/Status > Status).
- At 14 mV or less, "Weak Sensor" is shown on the UD10-DCU display for about 20 seconds, then a Cal Fault is shown. The Cal Log shows "Cal Fail" with a Span value of 0.00 mV.

## K FACTOR

If the system will be detecting a gas/vapor other than the gas used in the actual calibration process, a conversion K-Factor must be used. The K-Factor can be entered prior to calibration by navigating to the "Device Option" menu.

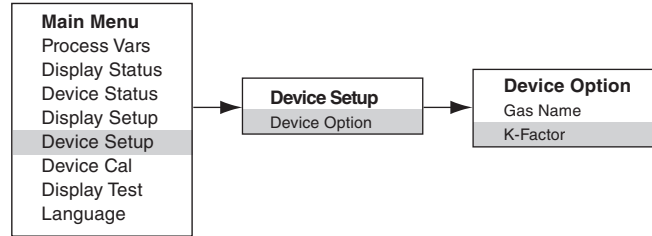

The UD10-DCU communicates the K-Factor to the CGS Interface Board during the calibration process, where the proper correction is made to ensure accurate calibration.

The actual effect of the K-Factor can be observed as the span portion of the calibration is completed. For example, suppose a K-Factor of 0.865 has been programmed. When calibration is performed, the UD10-DCU will display 50% as span is accepted. It will then apply the K-Factor, and the displayed value will change to 43.3% LFL.

For additional information regarding K-Factors, including a list of K-Factors for many common gases, refer to Technical Bulletin number 76-1017.

## MENU STRUCTURE

### UD10-DCU with CGS Series Sensor

Refer to the following menu when using the UD10-DCU's LCD display and internal magnetic switches.

#### MENU HELP

*Status menus only allow the user to view the data.  
The Setup menus allow the user to both view and edit the data.*

# APPENDIX M

## UD10-DCU with MODEL 505 TRANSMITTER / CGS SENSOR

### NOTE

For complete information regarding the Model 505 Transmitter, refer to instruction manual 95-8472.

## WIRING

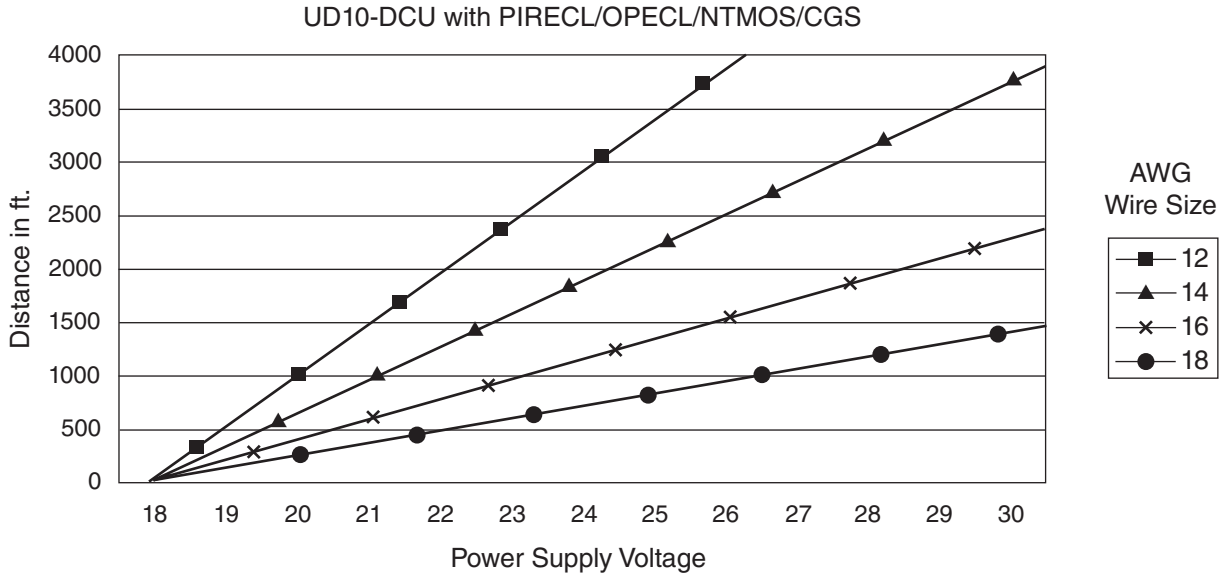

Notes: Maximum recommended cable length from power source to UD10 is 2000 feet.  
 Maximum recommended cable length from UD10 to CGS sensor is 500 feet (using 16 AWG, 1.5 mm<sup>2</sup> cable minimum).

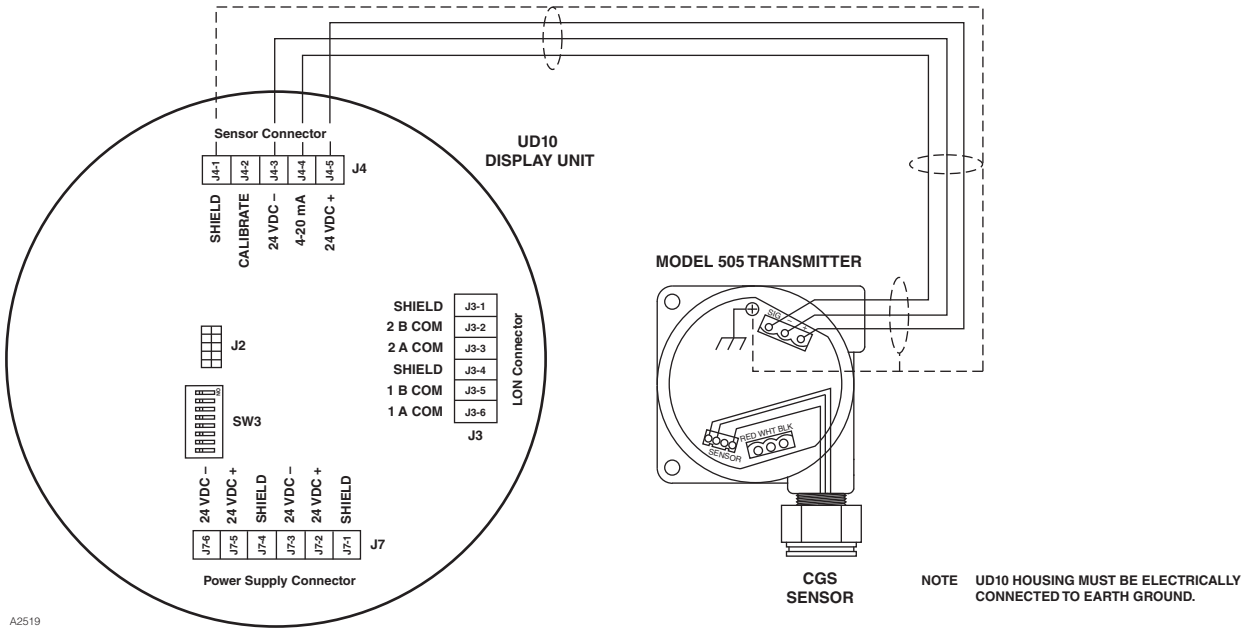

UD10-DCU Wired to Model 505 Transmitter/CGS Sensor

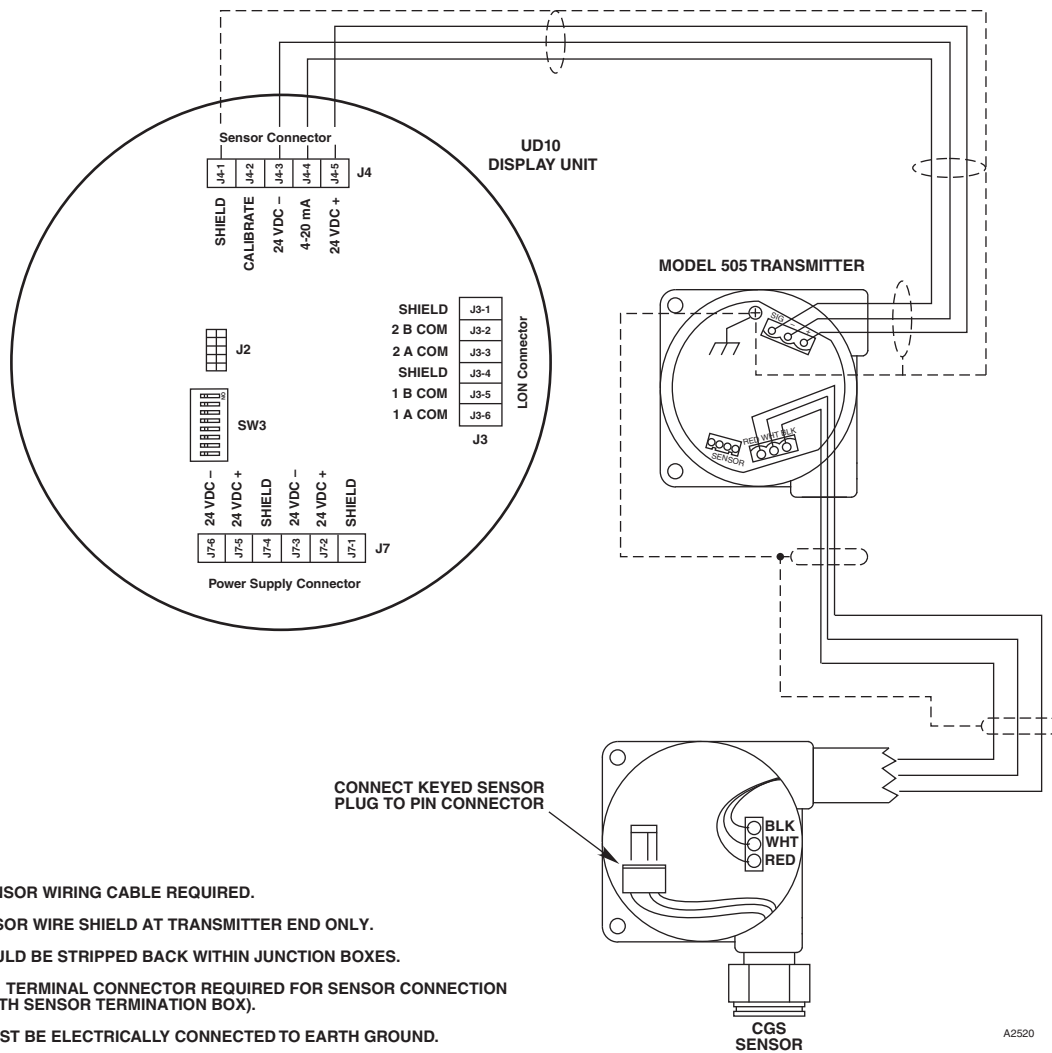

UD10-DCU Wired to Model 505 Transmitter/CGS Sensor Using Sensor Separation Termination Box

## INSTALLATION

Refer to the Model 505 Instruction Manual (number 95-8472) for complete information regarding proper installation of the Model 505 with combustible gas sensor.

## ORIENTATION

The Model 505/CGS must be mounted with the CGS sensor opening pointing down.

# CALIBRATION

## NOTE

For maximum calibration accuracy, allow a new sensor to operate under power for several hours (minimum one hour) to ensure a stable output before performing calibration. For the highest degree of accuracy, perform a second calibration after 24 hours.

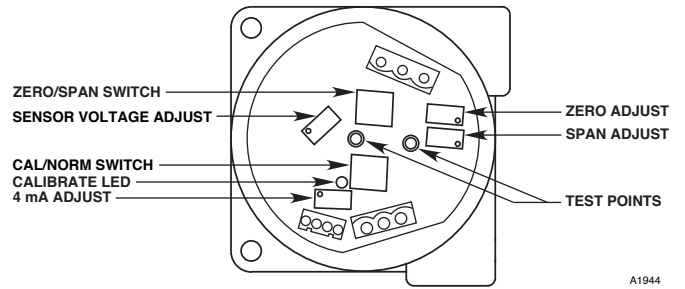

## Model 505

The Model 505/CGS must be calibrated when the system is commissioned as well as when the CGS sensor is replaced. Calibration is performed at the Model 505 using the following procedure. Calibration at the UD10-DCU is not supported.

<b>WARNING</b>		
<i>Before removing the junction box cover, verify that no dangerous levels of gas are present.</i>		
Step	Switch Position	Operator Action
1	CAL/NORM switch in the CAL position.	<ol style="list-style-type: none"> <li>1. LED turns on.</li> <li>2. Connect a digital voltmeter to the transmitter test jacks.</li> <li>3. Set the meter range to 2 Vdc.</li> </ol>
2	ZERO/SPAN switch in the ZERO position.	<ol style="list-style-type: none"> <li>1. Adjust the ZERO potentiometer to read 0.000 Vdc on the voltmeter. See Note 3 below.</li> </ol>
3	ZERO/SPAN switch in the SPAN position.	<ol style="list-style-type: none"> <li>1. Adjust the 4 mA potentiometer to read 0.167 Vdc on the voltmeter.</li> <li>2. Apply the 50% LFL calibration gas to the sensor. When the output has stabilized, adjust the SPAN potentiometer for a reading of 0.500 on the voltmeter.</li> </ol>
4	ZERO/SPAN switch in the ZERO position.	<ol style="list-style-type: none"> <li>1. Sensitivity test. The meter must read greater than 0.015 Vdc. See Note 4 below.</li> <li>2. Remove the calibration gas.</li> <li>3. When the meter reads 0.002 Vdc or less, remove the test probes.</li> </ol>
5	CAL/NORM switch in NORM position.	<ol style="list-style-type: none"> <li>1. The LED turns off.</li> <li>2. The calibration is complete.</li> <li>3. Replace the junction box cover.</li> </ol>

## NOTES:

1. When the CAL/NORM switch is in the CAL position, the yellow LED turns on and the 4-20 mA output signal goes to 3.4 mA.
2. The voltmeter must be suitable for use in a hazardous location.
3. If the possibility of background gases exists, purge the sensor with clean air prior to the zero adjustment to assure accurate calibration.
4. A typical sensitivity reading with 50% LFL gas applied to the sensor is 35 to 50 millivolts for a new sensor. Sensor replacement is recommended when the sensitivity reading is less than 15 millivolts.
5. If a dust cover or splash shield is used, inspect it to be sure that it is not dirty or plugged. A plugged dust cover can restrict the flow of gas to the sensing element, seriously reducing its effectiveness. For optimum performance, sensor covers/filters should be replaced frequently to ensure that they are not degraded or plugged.

## **MENU STRUCTURE**

### **UD10-DCU with Model 505 / CGS Sensor**

Refer to the following menu when using the UD10-DCU's LCD display and internal magnetic switches.

#### ***MENU HELP***

*Status menus only allow the user to view the data.  
The Setup menus allow the user to both view and edit the data.*

## APPENDIX N

### UD10-DCU with GENERIC 4-20 mA SENSORS

#### NOTE

*For complete information regarding installation, wiring, and calibration of the sensor, refer to the instruction manual provided by the sensor manufacturer.*

### OPERATION

The UD10-DCU can be used with generic sensors that generate a calibrated linear 4-20 mA signal, with or without HART. The UD10-DCU allows the operator to select the upper and lower range values and unit of measurement. The UD10-DCU then analyzes the 4-20 mA input signal from the sensor and displays the value with the designated measurement unit, and also controls the alarm outputs.

### UPPER AND LOWER RANGE VALUES

The upper range value (URV) and lower range value (LRV) are selected using the magnetic tool and the UD10-DCU's menu system (Main Menu > Device Setup). The URV corresponds to the 20 mA signal while the LRV corresponds to 4 mA. The default values are 0 for the LRV and 100 for the URV. When the generic detector supports HART communication, the URV and LRV come from the attached detector.

### MEASUREMENT UNIT TEXT

The operator can select the appropriate measurement unit from a pre-entered list: % (default), PPM, LFL, or PPB, or he can enter his own custom 4-character string. Measurement unit text is displayed on the main screen with the process variable. When the generic detector supports HART communication, the unit text comes from the attached detector.

### LOW FAULT THRESHOLD

The operator can enter a low input fault threshold in the range of 0.5 to 4 mA (default is 3.5 mA). When the input signal is at or below this point, an "Out of Range Low Fault" is annunciated. This feature can be enabled/disabled as desired.

### HIGH FAULT THRESHOLD

The operator can enter a high input fault threshold in the range of 20 to 27 mA (default is 21 mA). When the input signal is at or above this point, an "Out of Range High Fault" is annunciated. This feature can be enabled/disabled as desired.

### ALARMS

The Low, High and Auxiliary alarm levels are independently field adjustable. Alarm levels are set and displayed with the selected measurement units. All alarm levels must be within the LRV to URV range.

### ALARM LATCHING

Latching or non-latching function is independently selectable for each alarm. The default setting is non-latching. Latched alarms can be reset with a "Reset Latched Alarms" command from the menu system or a power cycle.

### SENSOR CALIBRATION

The UD10-DCU does not support generic sensor calibration. Generic sensors must be pre-calibrated following the procedure described in the instruction manual provided by the sensor manufacturer.

### 4-20 MA OUTPUT READING

While in Generic mode, the UD10-DCU displays values below the 4 mA level to allow the use of 0-20 mA sensors.

### MENU STRUCTURE

#### UD10-DCU with Generic 4-20 mA Sensors

Refer to the following menus when using the UD10-DCU's LCD display and internal magnetic switches. Two different menus are provided to accommodate sensors with or without HART communication.

#### MENU HELP

*Status menus only allow the user to view the data. The Setup menus allow the user to both view and edit the data.*

## APPENDIX O

### UD10-DCU with FLEXSONIC ACOUSTIC GAS DETECTOR

#### NOTE

For complete information regarding the FlexSonic Acoustic Detector, refer to instruction manual 95-8657.

## WIRING

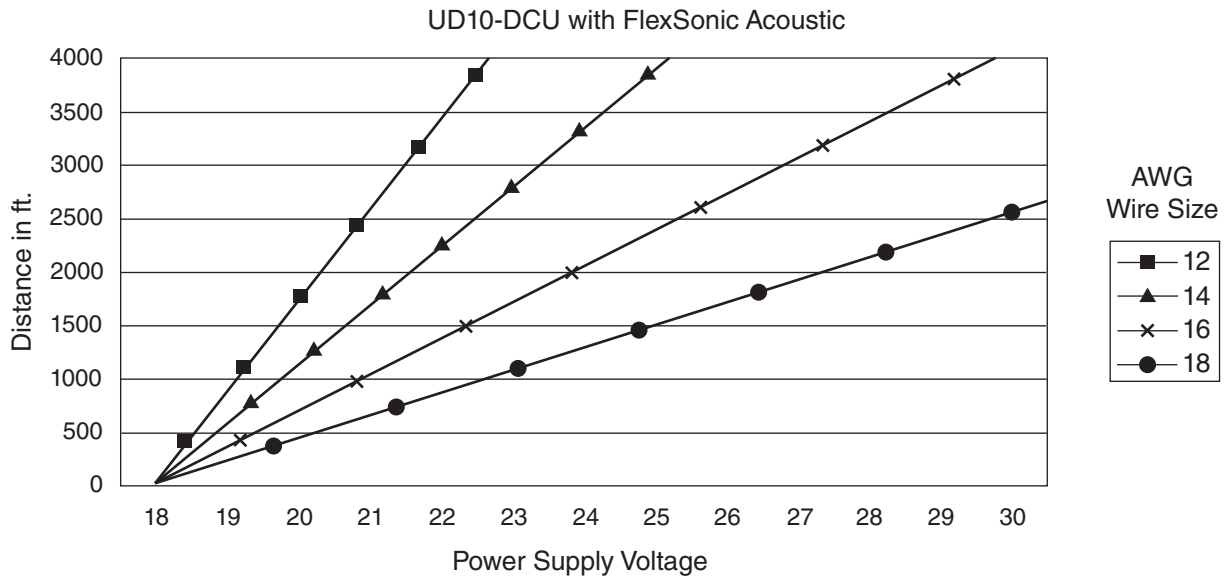

Notes: Maximum recommended cable length from power source to UD10-DCU is 2000 feet.  
Maximum recommended cable length from UD10-DCU to sensor is 2000 feet.

## INSTALLATION

#### NOTE

Detector housings must be electrically connected to earth ground. A dedicated earth ground terminal is provided.

#### NOTE

The AC100 has an Intrinsic Safety (IS) Barrier. Proper NEC/CEC IS grounded must be ensured.

#### NOTE

The detector must always be installed per local installation codes.

#### NOTE

Use of a threaded adapter for connecting the AC100 to the STB or ATX10 is prohibited.

#### NOTE

The ATX10 transmitter module is shipped with the SD card installed in the memory module. A piece of tape has been installed to secure the card in place and prevent it from becoming dislodged during shipping. The shipping tape should be removed prior to commissioning the acoustic detector.

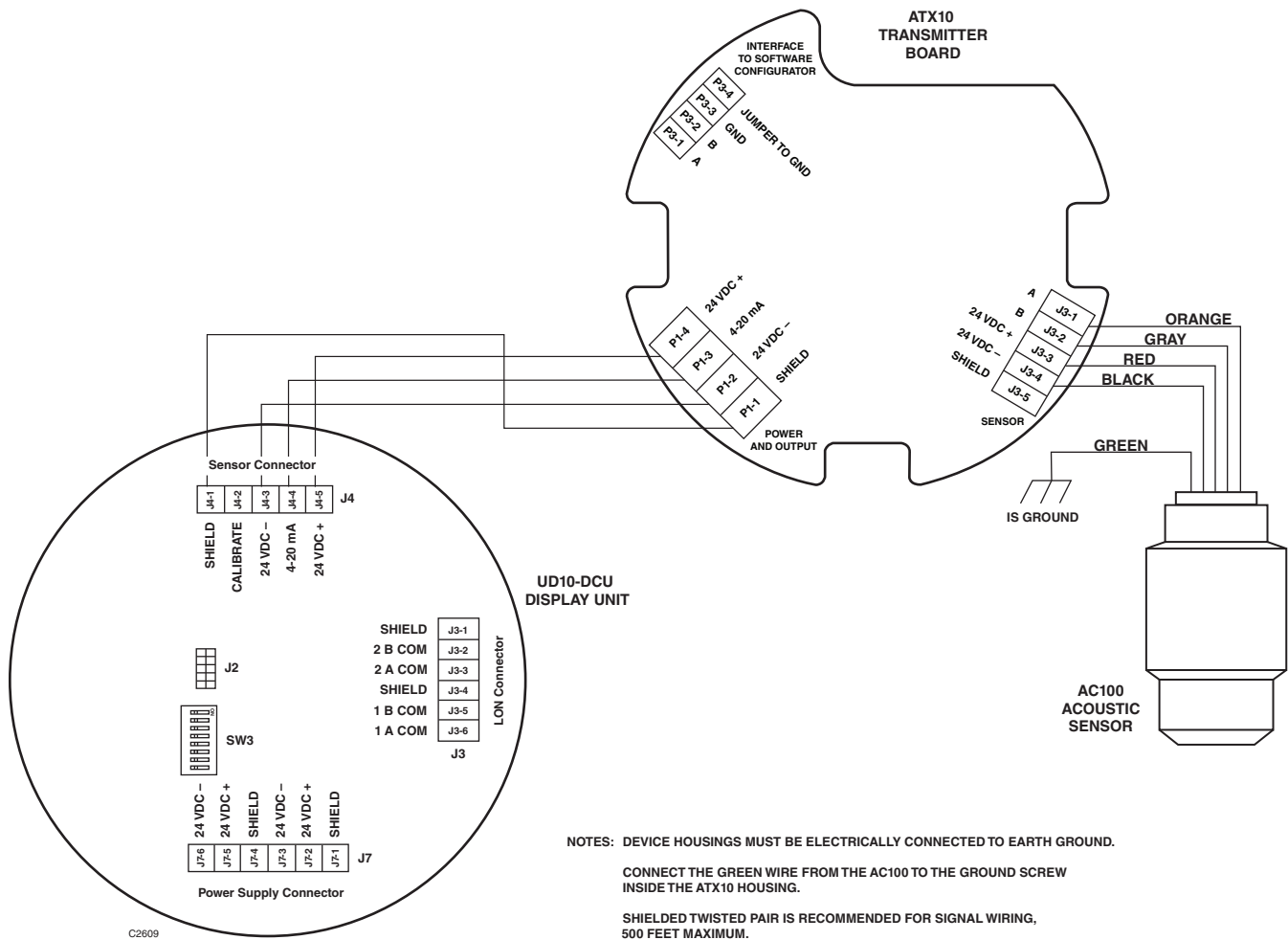

ATX10 Transmitter with AC100 Wired Directly to UD10-DCU

## UD10-DCU OPERATION

When used with the FlexSonic Acoustic Detector, the main UD10-DCU screen appears as shown in Figure 6-1. The selected alarm mode (Basic or Profile) is displayed in the upper right corner with the alarm level shown in dB. The current date and time are displayed at the bottom of the screen. Alarm or fault status information is shown at the top of the screen.

The spectrum display on the UD10-DCU uses 12 bands to summarize the FlexSonic Detector's 144 band spectrum in the following way:

- The first 4 bands summarize the audible range (20 Hz - 20 kHz). Each of the first 4 bands represents an aggregate of 30 bands from the spectrum, for a total of 120 bands. See Figure 6-2.
- The remaining 8 bands summarize the ultrasonic range from 20 kHz – 80 kHz. Each of the these bands represents an aggregate of 3 bands from the spectrum, for a total of 24 bands.

- The Y axis of the display represents the band amplitude in dB, scaled to fit the full height of the graph at the maximum amplitude of 139 dB.
- The amplitude of displayed bands is determined by taking the peak amplitude of the bands included within each of the aggregated groups of bands.

The alarm threshold is summarized in 12 bands using the method described above. The portion of the band that exceeds the alarm threshold is inverted (displayed in white) as shown in Figure 6-2.



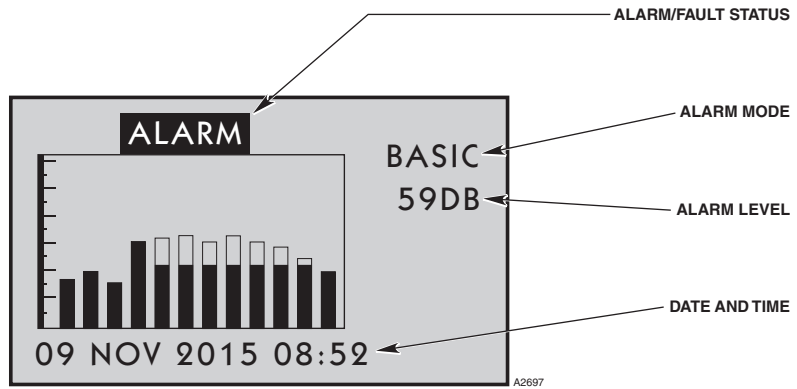

Figure 6-1—UD10-DCU Screen When Used with FlexSonic Acoustic Detector

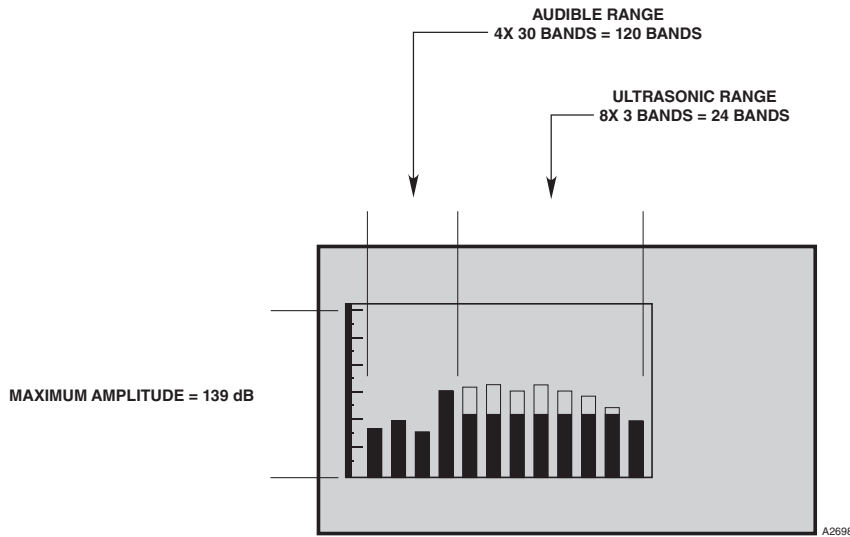

Figure 6-2—UD10-DCU Display Uses 12 Bands to Represent the FlexSonic Acoustic Detector's 144 Bands

## MENU STRUCTURE

### UD10-DCU with FlexSonic Acoustic Gas Detector

Refer to the following menu when using the UD10-DCU's LCD display and internal magnetic switches.

#### **MENU HELP**

*Status menus only allow the user to view the data.  
The Setup menus allow the user to both view and edit the data.*

# APPENDIX P

## UD10-DCU with MODEL PIRDUCT

### NOTE

For complete information regarding the PIRDUCT Gas Detector, refer to instruction manual 95-8573.

## WIRING

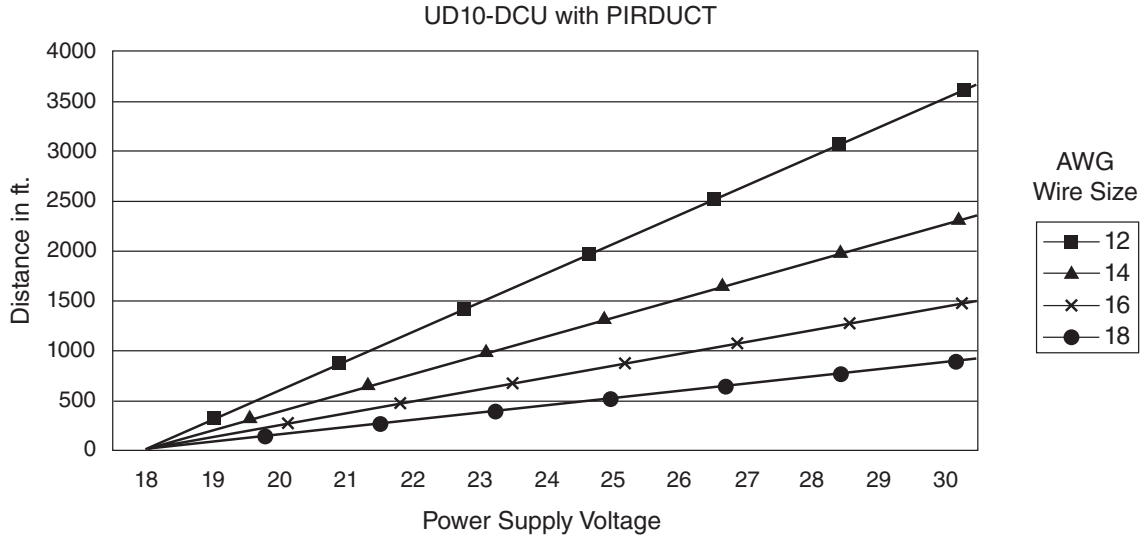

Notes: Maximum recommended cable length from power source to UD10-DCU is 2000 feet.  
 Maximum recommended cable length from UD10-DCU to PIR9400/PIRTB termination box is 2000 feet.

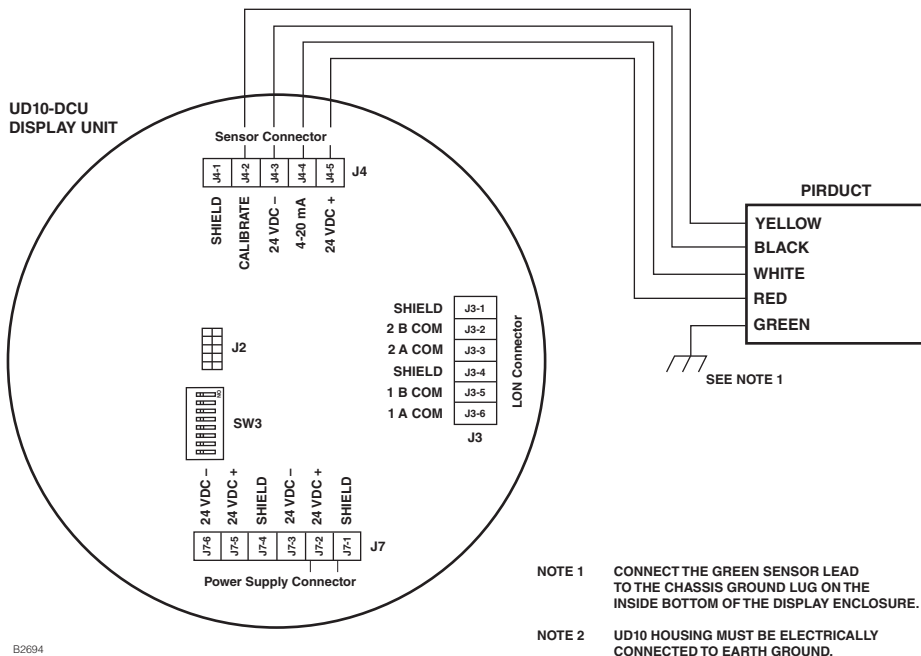

PIRDUCT Wired Directly to UD10-DCU

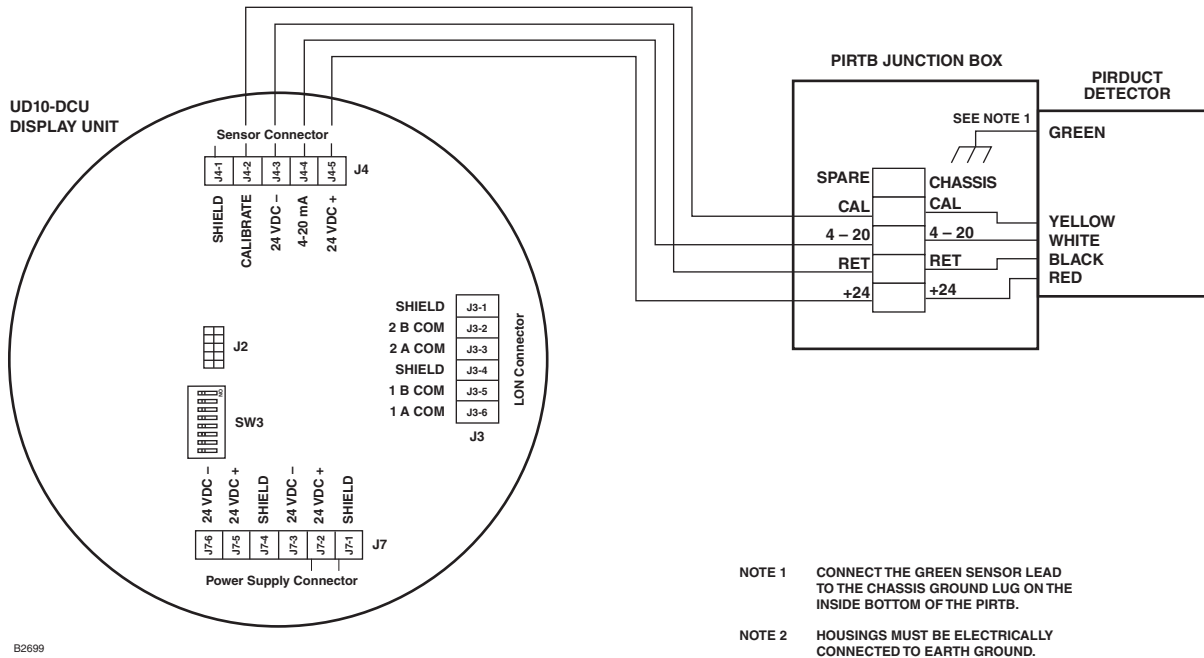

UD10-DCU Wired to PIRDUCT with PIRTB Termination Box

## INSTALLATION NOTES

### IMPORTANT

Hydrocarbon-based grease emits hydrocarbon vapors that will be measured by PIRDUCT, resulting in inaccurate gas level readings. **Use only low vapor pressure Lubriplate grease or Teflon tape on the PIRDUCT detector and associated termination box.** Do not get grease on the optics of the detector. A suitable grease is listed in the "Ordering Information" section in this manual.

### IMPORTANT

In applications where both PIRDUCT and catalytic type sensors are used, ensure that the grease used to lubricate the PIRDUCT detector threads does not come into contact with the catalytic sensors, since poisoning of the catalytic sensors could result. It is strongly recommended that maintenance personnel wash their hands between handling the two types of sensors.

## ORIENTATION

The PIRDUCT Detector is a position sensitive instrument. It must be installed in the proper orientation to achieve proper vapor detection. Ensure that the installation location selected will accommodate the instrument in the proper mounting orientation.

## CORRECT

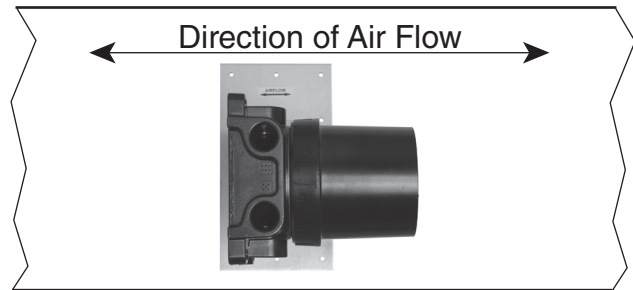

**IMPORTANT:** MOUNTING PLATE **MUST** BE ORIENTED AS SHOWN. ONCE THE MOUNTING PLATE IS SECURED TO THE DUCT WALL, THE TERMINATION BOX CAN BE ROTATED TO ANY CONVENIENT POSITION.

## INCORRECT



Orientation of PIRDUCT Mounting Plate Relative to Direction of Airflow through Duct

## CHANGING OPERATING MODES

When used with a PIRDUCT, the operating mode of the UD10-DCU must be changed from “HART Device” to “PIRDUCT” mode. Refer to the “Startup” section of this manual for details.

## CALIBRATION

To initiate calibration of the PIRDUCT from the UD10-DCU Display:

- Using the magnet to activate the switches on the UD10-DCU display, navigate to the “Calibration” menu.

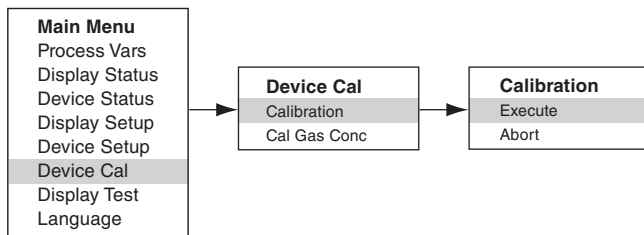

- Activate “Execute” (Enter/Select) to start calibration.
- The UD10-DCU will display “Waiting for Zero” on the main display screen.
- The UD10-DCU will then display “Waiting for Gas” on the screen.
- Apply calibration gas to the PIRDUCT.
- The UD10-DCU will continue to display “Waiting for Gas” on the screen.
- When the UD10-DCU displays “Remove Cal Gas” on the screen, remove the calibration gas from the PIRDUCT.
- The UD10-DCU automatically returns to the normal mode after successful calibration.

To initiate calibration from the PIRTB Termination Box while monitoring calibration using the UD10-DCU display:

- Using the magnet, activate the magnetic calibration switch on the PIRTB Termination Box. The LED at the PIRTB turns from off to steady red.
- The UD10-DCU will display “Waiting for Zero” on the main display screen, with a steady red LED at the PIRTB.

UD10-DCU mA Output During Calibration (UD10 with PIR9400)		
UD10-DCU Display Reading	Standard Mode	Replicate Mode
Waiting for Zero	3.8	2.2
Waiting for Gas	3.8	3.8
Waiting for Span	3.8	3.8
Remove Cal Gas	3.8	3.8
Back to Normal	4.0	4.0

- The UD10-DCU will then display “Waiting for Gas” on the screen, while the LED at the PIRTB is flashing red.
- Apply calibration gas to the detector.
- The UD10-DCU will display “Waiting for Span” on the screen, with a red flashing LED at the PIRTB.
- When the UD10-DCU displays “Remove Cal Gas” on the screen and the LED at the PIRTB turns off, remove the calibration gas.
- After successful calibration, the UD10-DCU automatically returns to the normal mode, and the LED on the PIRTB remains off.

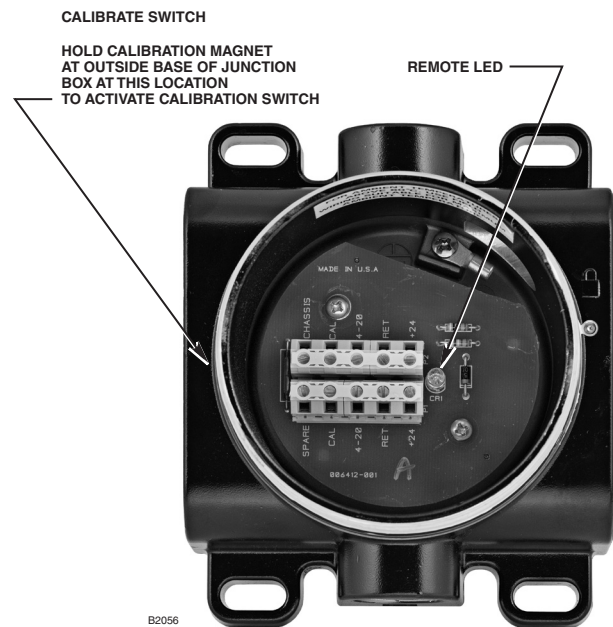

PIRTB Termination Box

## **MENU STRUCTURE**

### **UD10-DCU with PIRDUCT Gas Detector**

Refer to the following menu when using the UD10-DCU's LCD display and internal magnetic switches.

#### ***MENU HELP***

*Status menus only allow the user to view the data.  
The Setup menus allow the user to both view and edit the data.*

# APPENDIX Q

## UD10-DCU with MODEL PIRECL CARBON DIOXIDE DETECTOR

### NOTE

For complete information regarding the PIRECL CO<sub>2</sub> Gas Detector, refer to instruction manual 95-8676.

## WIRING

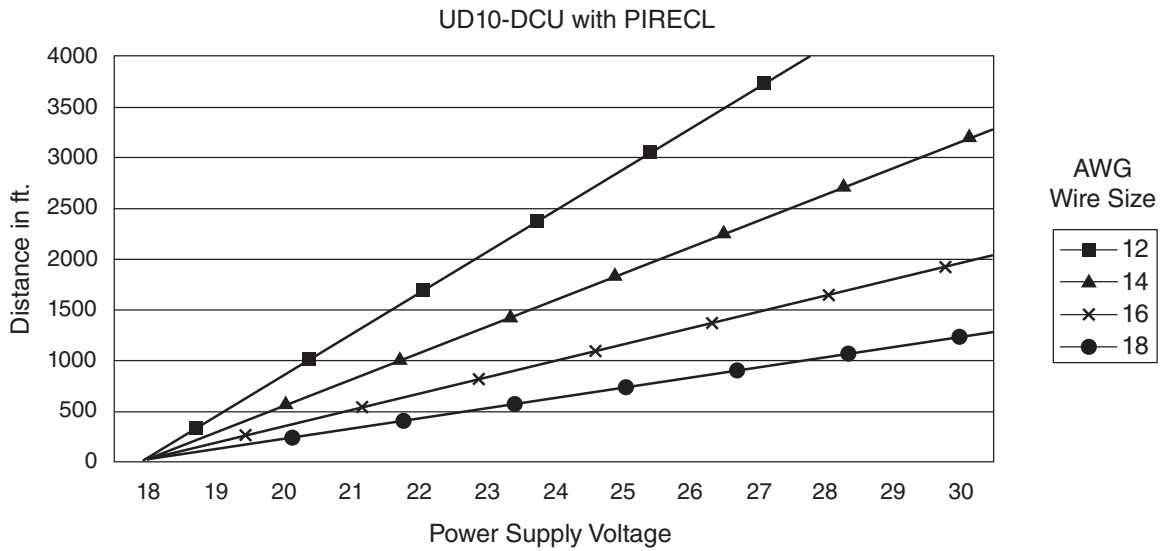

Notes: Maximum recommended cable length from power source to UD10-DCU is 2000 feet.  
Maximum recommended cable length from UD10-DCU to detector/STB termination box is 2000 feet.

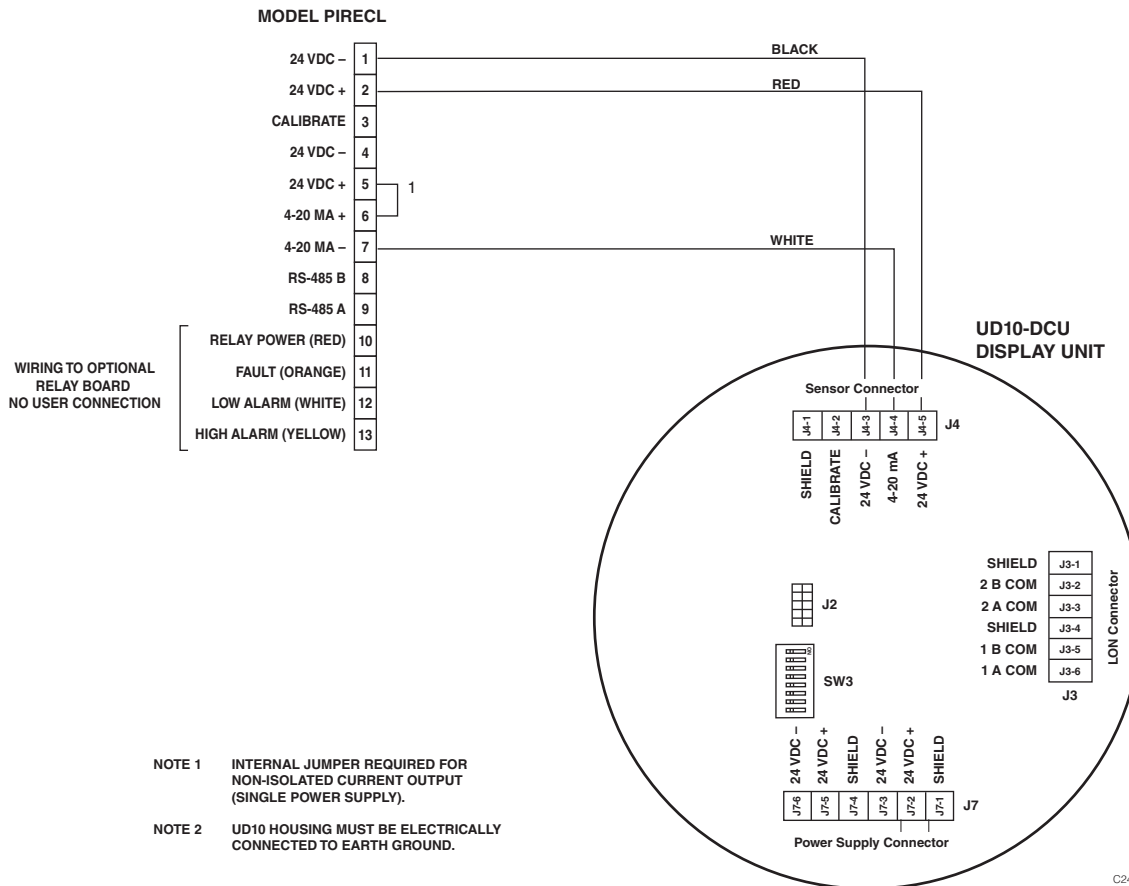

Model PIRECL CO<sub>2</sub> Wired Directly to UD10-DCU

## ORIENTATION

It is highly recommended that the PIRECL CO<sub>2</sub> be installed in the horizontal position. The detector is not position-sensitive in terms of its ability to detect gas. However, the weather baffle assembly provides superior performance when the PIRECL CO<sub>2</sub> is installed with the baffle in a horizontal position.

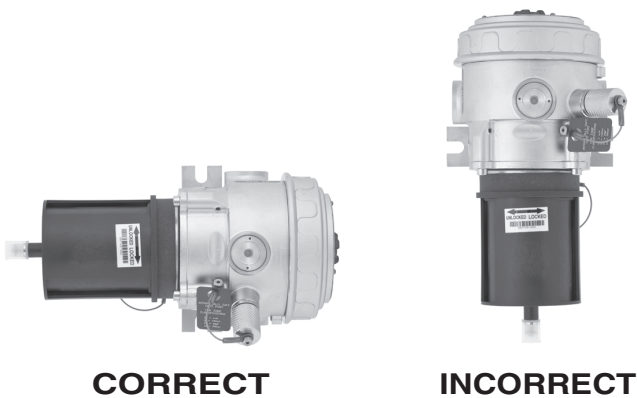

# CALIBRATION

To initiate calibration of the PIRECL CO<sub>2</sub> from the UD10-DCU Display:

- Using the magnet to activate the switches on the UD10-DCU display, navigate to the "Calibration" menu.

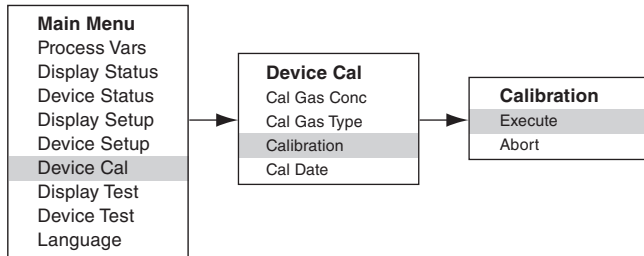

- Activate "Execute" (Enter/Select) to start calibration.
- The UD10-DCU will display "Waiting for Zero" on the main display screen, with a solid red LED on the PIRECL CO<sub>2</sub> housing illuminated.
- The UD10-DCU will then display "Waiting for Gas" on the screen, while the LED on the PIRECL CO<sub>2</sub> is flashing red.
- Apply calibration gas to the PIRECL CO<sub>2</sub>.
- The UD10-DCU will display "Waiting for Span" on the screen, while a red flashing LED on the PIRECL CO<sub>2</sub> housing is illuminated.
- When the UD10-DCU displays "Remove Cal Gas" on the screen and the LED on the PIRECL CO<sub>2</sub> housing is off, remove the calibration gas.
- After successful calibration, the UD10-DCU automatically returns to the normal display with the green LED illuminated on the PIRECL CO<sub>2</sub> housing.

To initiate calibration from the PIRECL CO<sub>2</sub> while monitoring calibration using the UD10-DCU display:

- Using the magnet, activate the magnetic calibration switch on the PIRECL CO<sub>2</sub> detector. See Figure below. The LED turns from green to red.
- The UD10-DCU will display "Waiting for Zero" on the main display screen, with a solid red LED on the PIRECL CO<sub>2</sub> housing illuminated.
- The UD10-DCU will then display "Waiting for Gas" on the screen, while the LED on the PIRECL CO<sub>2</sub> is flashing red.
- Apply calibration gas to the PIRECL CO<sub>2</sub> detector.
- The UD10-DCU will display "Waiting for Span" on the screen, while a red flashing LED on the PIRECL CO<sub>2</sub> housing is illuminated.
- When the UD10-DCU displays "Remove Cal Gas" on the screen and the LED on the PIRECL CO<sub>2</sub> housing is off, remove the calibration gas.
- After successful calibration, the UD10-DCU automatically returns to the normal mode with the green LED illuminated on the PIRECL CO<sub>2</sub>.

UD10-DCU mA Output During Calibration (UD10 with PIRECL CO <sub>2</sub> )		
UD10-DCU Display Reading	Standard Mode	Replicate Mode
Waiting for Zero	3.8	2.2
Waiting for Gas	3.8	2.0
Waiting for Span	3.8	2.0
Remove Cal Gas	3.8	1.8
Back to Normal	4.0	4.0

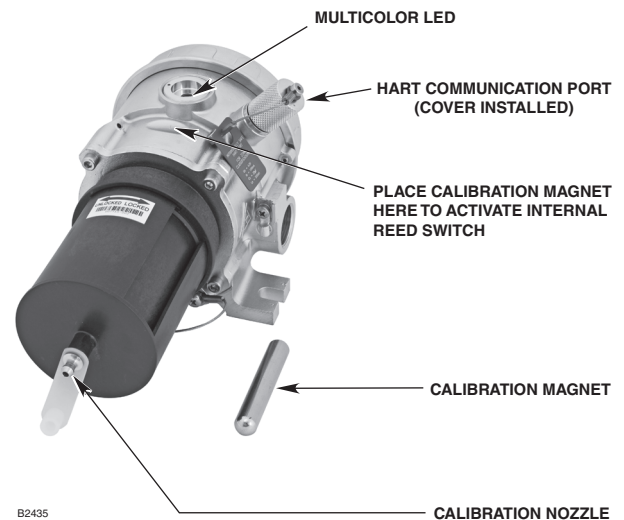

Model PIRECL CO<sub>2</sub> Gas Detector



## **MENU STRUCTURE**

### **UD10-DCU with Model PIRECL CO<sub>2</sub> Gas Detector**

Refer to the following menu when using the UD10-DCU's LCD display and internal magnetic switches.

#### ***MENU HELP***

*Status menus only allow the user to view the data.*

*The Setup menus allow the user to both view and edit the data.*

# APPENDIX R

## UD10-DCU with LS2000 LINE OF SIGHT GAS DETECTOR

### NOTE

For complete information regarding the LS2000 Gas Detector, refer to instruction manual 95-8714.

### WIRING

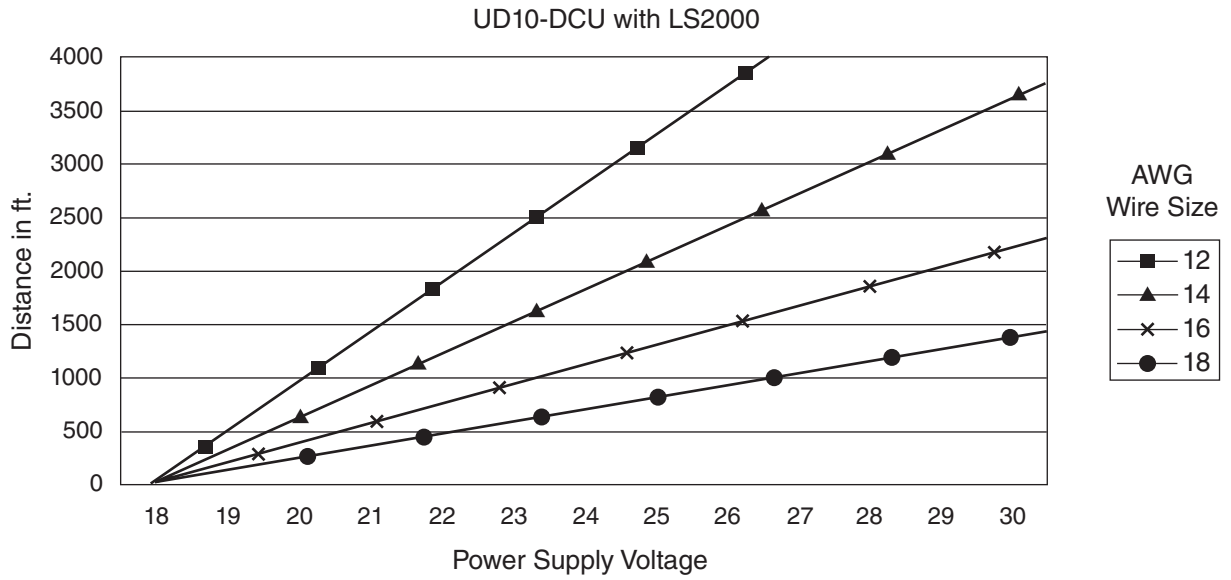

Notes: Maximum recommended cable length from power source to UD10-DCU is 2000 feet.  
Maximum recommended cable length from UD10-DCU to sensor is 2000 feet.

**LS2000 RECEIVER WITHOUT RELAYS**

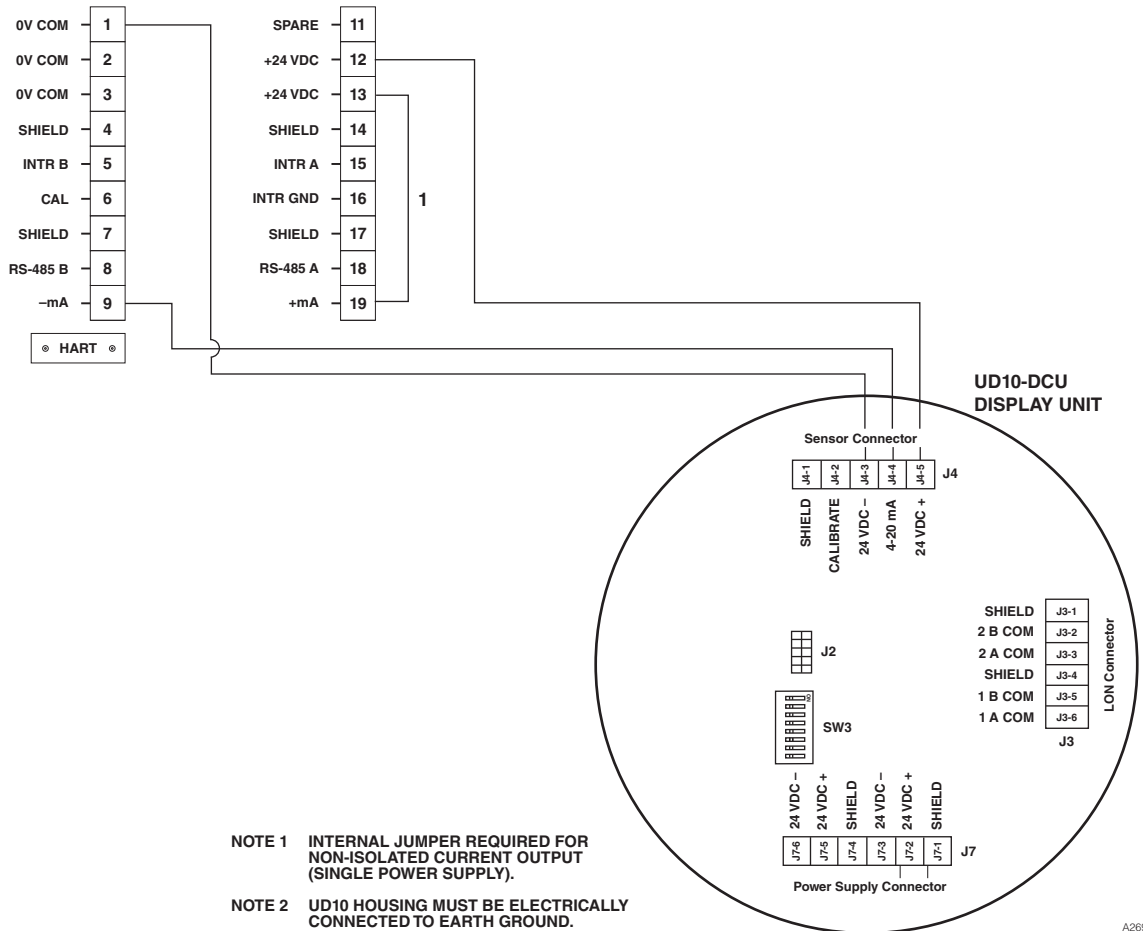

- NOTE 1 INTERNAL JUMPER REQUIRED FOR NON-ISOLATED CURRENT OUTPUT (SINGLE POWER SUPPLY).
- NOTE 2 UD10 HOUSING MUST BE ELECTRICALLY CONNECTED TO EARTH GROUND.

A2695

LS2000 Wired Directly to UD10-DCU

## INSTALLATION

LS2000 modules must be affixed to a solid, non-vibrating structure capable of supporting a minimum of 100 lbs (46 kg), located within the system's rated separation distance. See examples below.

In all cases, consider whether additional bracing or support is needed to ensure the structural integrity of the module installation. Remember that accurate module alignment is essential for proper performance of a line-of-sight gas detection system. Movement may have a detrimental effect on alignment. This is especially true for installations with significant module separation distances.

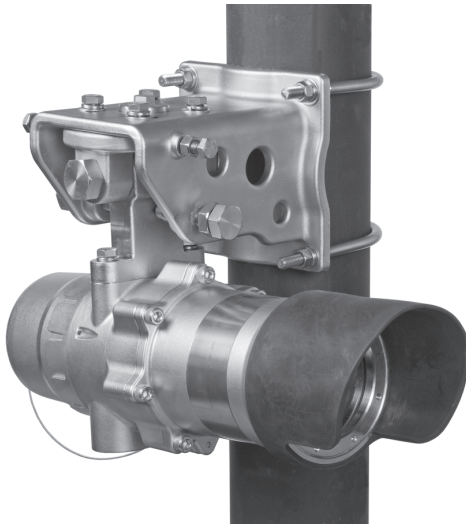

LS2000 Gas Detector Mounted to Vertical Post

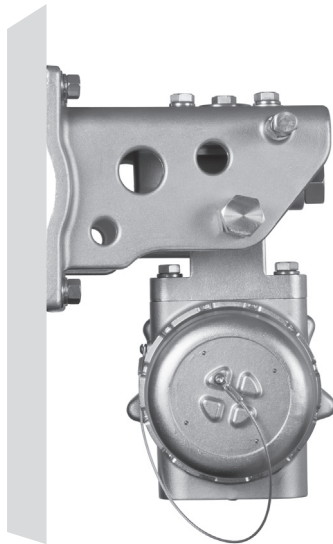

LS2000 Gas Detector Mounted to Flat Surface  
(Refer to LS2000 Instruction Manual for mounting plate hole spacing dimensions.)

## CALIBRATION

To initiate zero calibration of the LS2000 from the UD10-DCU Display:

1. Using the magnet to activate the switches on the UD10-DCU display, navigate to the "Calibration" menu.

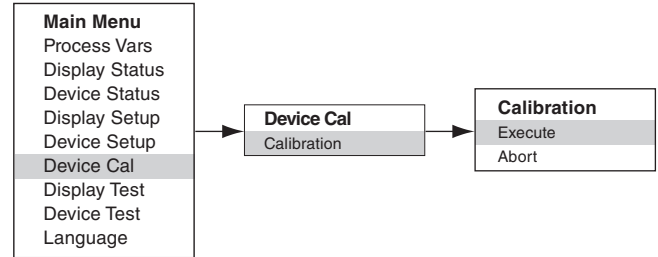

2. Activate "Execute" (Enter/Select) to start calibration.
3. The UD10-DCU will display "Waiting for Zero" on the main display screen, with a solid red LED on the LS2000 housing illuminated.
4. After the calibration is successfully completed, the UD10-DCU automatically returns to the normal display with the green LED illuminated on the LS2000 housing.

To initiate zero calibration from the LS2000:

1. Using the magnet, activate the magnetic calibration switch on the LS2000 receiver. See Figure below. The green LED will turn red.
2. The UD10-DCU will display "Waiting for Zero" on the main display screen, with a solid red LED on the LS2000 housing illuminated.
3. After the calibration is successfully completed, the UD10 automatically returns to the normal display with the green LED illuminated on the LS2000 housing.

## MENU STRUCTURE

### UD10 with LS2000 Line of Sight Gas Detector

Refer to the following menu when using the UD10-DCU's LCD display and internal magnetic switches.

#### **MENU HELP**

*Status menus only allow the user to view the data.  
The Setup menus allow the user to both view and edit the data.*

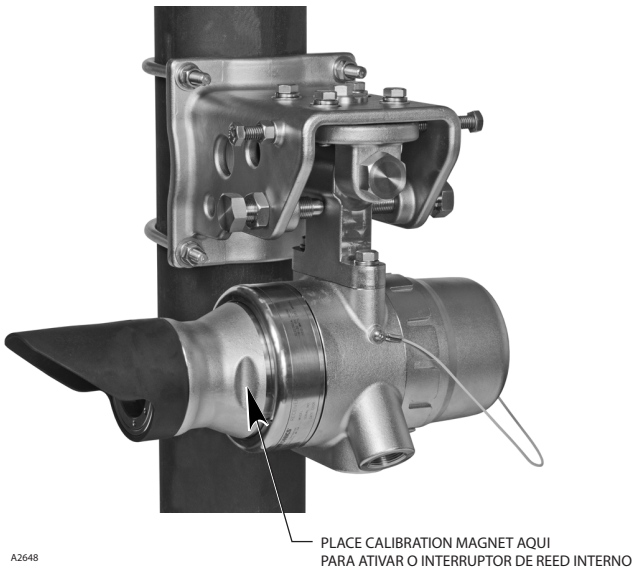

Location of Receiver's Internal Magnetic Switch



95-8656



FlexSonic® Acoustic Leak Detector



X3301 Multispectrum IR Flame Detector



PointWatch Eclipse® IR Combustible Gas Detector



FlexVu® Universal Display with GT3000 Toxic Gas Detector



Eagle Quantum Premier® Safety System

Specifications subject to change without notice.

All trademarks are the property of their respective owners. © 2020 Detector Electronics Corporation. All rights reserved.

Det-Tronics manufacturing system is certified to ISO 9001—the world's most recognized quality management standard.



**Corporate Office**  
6901 West 110<sup>th</sup> Street  
Minneapolis, MN 55438 USA  
[www.det-tronics.com](http://www.det-tronics.com)

Phone: +1 952.941.6665  
Toll-free: +1 800.765.3473  
Fax: 952.829.8750  
det-tronics@carrier.com