

Instructions

Combustible Gas
Transmitter Model CTX10 with
Combustible Gas Sensor Model CGS



Table of Contents

SAFETY MESSAGES	i
1.0 APPLICATION	1
2.0 DESCRIPTION	1
2.1 Sensor.....	1
2.2 Sensor Response	1
2.3 Factors Affecting Sensor Sensitivity	1
2.4 CTX10 Operating Modes, 0-20 mA Output Levels.....	2
2.5 Calculating % LFL	3
2.6 CTX10 LEDs	4
3.0 SPECIFICATIONS	4
3.1 Transmitter (CTX10).....	4
3.2 Catalytic Sensor (CGS).....	4
4.0 INSTALLATION	5
4.1 Sensor Location	5
5.0 Wiring	
5.1 Wire Size and Type	6
5.2 Model CTX10 Wiring.....	7
5.3 Sensor Separation	7
6.0 STARTUP	7
7.0 CALIBRATION.....	8
7.1 Calibration Procedure.....	8
7.2 Calibration using K-Factors	9
8.0 TROUBLESHOOTING	10
9.0 MAINTENANCE	10
9.1 Checkout in Normal Mode.....	10
9.2 Sensor Inspection.....	10
9.3 Sensor Replacement	10
10.0 REPAIR AND RETURN	11
11.0 ORDERING INFORMATION.....	11
11.1 Spare Parts and Accessories	11
11.2 CTX10 Model Matrix	12

APPENDICES

APPENDIX A - FM APPROVAL	13
APPENDIX B - CSA APPROVAL	14
APPENDIX C - ATEX APPROVAL	15
APPENDIX D - IECE _x APPROVAL	17
APPENDIX E - ADDITIONAL APPROVALS	19
APPENDIX F - DIP SWITCH SETTINGS & K-FACTOR TABLE.	20
APPENDIX G - CTX10 With CGS GAS SENSOR	22

Safety Messages

IMPORTANT

Be sure to read and understand the entire instruction manual before installing, operating or servicing the gas detection equipment.



WARNING

Do not open the transmitter enclosure with power applied unless it is verified that no combustible gases or vapors are present. A portable gas detection instrument should be used to ensure that the area is clear of any combustible gases. Calibration or maintenance should not be performed if there is any indication of the presence of combustible gas at the sensor.



WARNING

It is possible for the transmitter output to drop to a low LFL level after going into high alarm and still have a dangerous level of combustible gas present. Therefore, precautions should be taken to ensure that the combustible gas has been cleared before considering the area safe.



WARNING

The sintered metal flame arrestor is an integral part of the combustible gas sensor. DO NOT operate the gas detector if the flame arrestor is damaged or missing, since the exposed element is a potential ignition source.

IMPORTANT

Metric Sensors must provide five (5) threads of engagement. NPT Sensors must provide five (5) threads available.

CAUTION

To ease installation and future removal, ensure that all junction box covers and sensor threads are properly lubricated. If the need arises for additional lubrication, use either Lubriplate grease (P/N 005003-001) or Teflon paste for sensor threads. **Avoid the use of silicone grease.**

CAUTION

The wiring instructions in this manual will provide safe and proper functioning of the device under normal conditions. However, local variations in wiring codes and regulations exist, and total compliance with these ordinances cannot be guaranteed. Be certain that all wiring complies with the IEC/NEC as well as all local ordinances. If in doubt, consult the local authority having jurisdiction (AHJ) before wiring the system.

NOTE

Throughout this manual, the device receiving the output signal from the transmitter will be referred to as the "controller." A typical controller provides a visual display of the % LFL output from the monitored transmitter, indicators for alarm and trouble conditions, and outputs for controlling response devices. Other control systems are also compatible with the CTX10.

Combustible Gas Transmitter Model CTX10 with Combustible Gas Sensor Model CGS

1.0 APPLICATION

The model CGS sensor when used with the CTX10 is a catalytic combustible gas detector that provides continuous monitoring of combustible hydrocarbon gas and combustible hydrogen gas concentrations in the range of 0% LFL to 100% LFL. The CTX10 is approved for methane and propane gases.

2.0 DESCRIPTION

The Model CTX10 Transmitter (CTX10) is used with one constant current catalytic gas sensor to provide a linear 4 to 20 mA output signal corresponding to a 0 to 100% LFL gas concentration. Non-intrusive calibration and sensor sensitivity checks are performed using a magnetic switch (magnet not provided, use Det-Tronics P/N 009700-001).

An explosion-proof junction box with removable cover is included with all CTX10s. Options include the junction box material (aluminum or stainless steel), conduit entry threads (3/4" NPT or M20) and approvals. The CTX10 replaces the Model 505 product.

2.1 SENSOR

Det-Tronics constant current catalytic bead type combustible gas sensors are used with the CTX10 family of transmitters.

NOTE:

CGS sensors with flying leads (Model Code Lead Length Option 5) should be ordered for use with the CTX10 transmitter.

2.2 SENSOR RESPONSE

All catalytic sensors require oxygen to accurately measure combustible gas concentrations. Sensor response and accuracy will decrease when the oxygen level is less than 10%. Do not use catalytic gas sensors in areas where the oxygen level is less than 10% by volume.



2.3 FACTORS AFFECTING SENSOR SENSITIVITY

There are a variety of factors that can cause a decrease in the sensitivity of catalytic type combustible gas sensors. The following information identifies the most common substances that can have a detrimental effect on the catalytic gas sensor. Under no circumstances should these lists be considered as all inclusive.

Interfering or contaminating substances include materials that can clog the pores of the sintered steel flame arrestor and reduce the gas diffusion rate to the sensor. Examples include:

2.3.1 Dirt or oil

A dust cover or splash guard should be installed to protect the flame arrestor. The dust cover may be cleaned using an organic solvent and an ultrasonic bath unless the contaminant is insoluble. Replace dust cover if there is any doubt.

2.3.2 Corrosive liquids and vapors

Corrosion of sensor and detector can occur when substances such as H₂S (hydrogen sulfide), Cl₂ (chlorine) or HCl (hydrochloric acid) are present. A dust cover may provide some limited protection. Routine calibration frequency should be increased in applications where corrosive materials are present.

2.3.3 Flame arrestor clogged as a result of painting or cleaning

The routine maintenance procedure should include first powering down the system, then covering the sensor with a plastic bag when painting or cleaning. The bag should be removed as soon as possible when the procedure is complete. Recalibrate the sensors after re-powering and stabilization.

2.3.4 Polymer formation in the flame arrestor

This can occur where monomeric vapors such as 1-3 butadiene, styrene, isoprene, etc. are present. This may render the sensor dead.

Some substances can cover up the active sites on the catalytic surface of the active sensing element. This occurs in the presence of volatile metal organics, gases, hydride vapors, and volatile compounds containing phosphorous, boron, silicon, etc.

Examples: Tetraethyl lead
Phosphine
Diborane
Silane
Trimethylchlorosilane
Hydrogen fluoride
Boron trifluoride
Phosphate esters
Silicone oils and greases
RTV silicone sealants

Some substances react with the catalytic element metal, forming a volatile compound. This erodes the metal from the surface. With sufficient exposure, most or all of the metal catalyst can be removed from the surface of the active element of the sensor. Halogens and compounds that contain halogens are materials of this nature.

Examples: Chlorine
Bromine
Iodine
Hydrogen Chloride,
Hydrogen Bromide or
Hydrogen Iodide
Organic halides
Trichloroethylene
Dichlorobenzene
Vinyl chloride
Freons
Halon 1301
(Bromotrifluoromethane)

A brief exposure to any of these materials may temporarily increase the sensitivity of the sensor due to etching of the catalytic surface. **This practice is not recommended, since it is unreliable and may give a false sense of security.**

Exposure to high concentrations of gas for extended periods can introduce stress to the sensing element and seriously affect its performance. After exposure to a high concentration of combustible gas, re-calibration should be performed and, if necessary, the sensor should be replaced.

The degree of damage to a catalytic sensor is determined by the type of contaminant, its concentration in the atmosphere, and the length of time the sensor is exposed. When a sensor has been exposed to a contaminant or to a high level of combustible gas, it should be re-calibrated, followed by an additional calibration a few days later to determine whether a significant shift in sensitivity has occurred.

2.4 CTX Operating Mode and 0- 20 mA Output Levels

The CTX10 is designed to as a replacement for installations using the Det-Tronics Model 505. The CTX10 transmitter can be configured for 1 of 3 operating modes: UD10/UD30, Model 505, and Infinity (U9500). These modes are configured using the DIP switch settings on the transmitter (Fig. A).

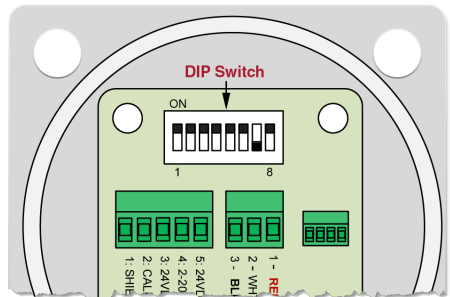

Figure A: DIP Switch Location

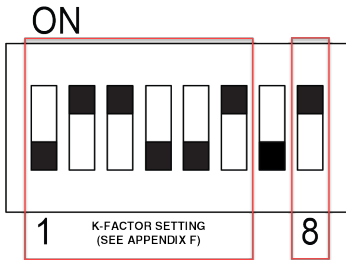

Figure B: Switch Settings for CTX10 in 505, Ininiti Mode(s)

Switch 8 (shown in Figure B above) determines the output mode of the transmitter:

- Sliding it to OFF selects 505 mode.
- Sliding it to ON (shown) selects Ininiti mode.

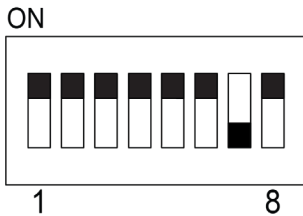

Figure C: Switch Settings for CTX10 in UD10/UD30 Mode

If using the CTX10 with either a UD10 or UD30, Switches 1 – 6 must be set to ON (see Figure B). The Mode Select switch (8) is ignored.

The Analog Output of the CTX10 has different levels for signaling states that depend on the mode selected. Refer to Table 1.

Detector Condition	505 Mode	Ininiti (U9500) Mode	UD10/UD30 Mode
Gas Level (0% to 100% Fullscale)	0 - 20	0 - 20	4 - 20
Warm-up	0.80	0.8	0.8
Fault	1.00	1.00	1.00
Cal Fault (Aborted Cal, Sensor End of Life)	1.6	1.6	1.6
Cal Fault (Aborted Cal))	3.4	1.6	1.6
Span Calibration (Apply Gas)	3.4	2.2	2.2
Zero Calibration (Complete/In progress)	3.4	2.2	2.2
Calibration (505 Mode)	3.4	1.8	1.8

Table 1: CTX10 Outputs Levels Versus Detector Status and Operating Modes.

2.5 CALCULATING LFL%

The LFL percentage for a given 4-20 mA current reading can be calculated using this formula:
 $\% \text{ LFL} = ((\text{mA} - 4) / 16) * 100$; where mA = current reading in milliamperes.

For example, when the device reads 12 mA:

$$\% \text{ LFL} = ((12 - 4) / 16) * 100$$

$$12 - 4 = 8$$

$$8 / 16 = 0.5$$

$$0.5 * 100 = 50$$

50% LFL is indicated

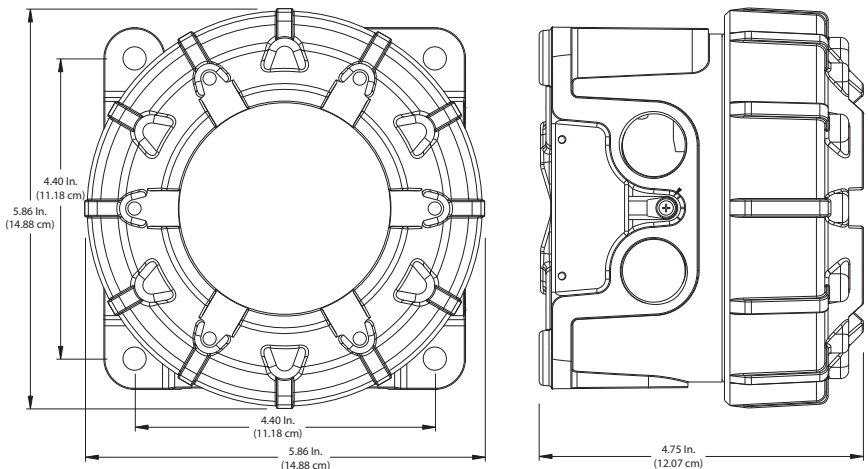

Figure 1—Dimensions of CTX10 Transmitter Junction Box in Inches (Centimeters)

2.6 CTX10 LEDS

Color	Function
Green	Power
Yellow	Calibration, Faults
Blue	End of Life Indication



3.0 SPECIFICATIONS

3.1 TRANSMITTER (CTX10)

INPUT VOLTAGE—

24 Vdc Nominal, approved operating range of 10 - 30 Vdc, Det-Tronics verified. Ripple cannot exceed 0.5 Volts P-P

POWER CONSUMPTION—

4.0 watts maximum

PEAK STARTUP CURRENT—

Less than 0.5 ampere for < 0.2 second at 10 Vdc input, and less than 0.2 ampere for < 0.2 second at 24 Vdc input.

OUTPUT CURRENT—

Linear 0 to 20 mA

GAS DETECTION—

4 - 20 mA (0 - 100% LFL)

CURRENT LEVEL—

Calibration Fault: 1.6 mA

Other Faults: 1.0 mA

Calibration Mode: 2.0/2.2 mA in Infiniti mode
3.4 mA in 505 mode

Mode selected via DIP switch (Refer to Appendix F)

LOAD RESISTANCE —

Output loop resistance: 250 Ohms to 600 Ohms

TEMPERATURE RANGE—

Operating: -40°F to +167°F (-40°C to +75°C).

Storage: -67°F to +185°F (-55°C to +85°C).

HUMIDITY RANGE (NON-CONDENSING)—

5 - 95% (Det-Tronics Verified)

20-90% (Performance Agency Verified)

ELECTRO-MAGNETIC COMPATIBILITY-

EMC Directive 2014/30/EU

EN 50270: 2015

EN 61000-6-4: 2007 +A1:2011

SHIPPING WEIGHT—

Aluminum: 3.8 lbs. (1.7 kg)

Stainless Steel: 8.7 lbs. (4.0 kg)

CTX10 DIMENSIONS—



See Figure 1

CERTIFICATION—

For complete approval details, refer to the appropriate Appendix:

Appendix A – FM

Appendix B – CSA

Appendix C – ATEX

Appendix D – IECEX

Appendix E - Additional approvals

Appendix F - Dip Switch Settings and K-Factor Table

SIL Approval

For specific information regarding SIL safety certification refer to Model CTX10 Safety Manual, document number: 95-8793.

3.2 CATALYTIC SENSOR (CGS)

TEMPERATURE RANGE—

Operating: -67°F to +257°F / -55°C to +125°C

Performance: -40°F to +167°F / -40°C to +75°C

HUMIDITY RANGE—

20 to 90% RH, non-condensing

PRESSURE RANGE—

86 kPa to 108 kPa (25.4 to 31.9 inHg)

RESPONSE TIME—

(100% LFL Gas Applied)

10 seconds Methane

16 seconds Propane

RECOVERY TIME—

Less than 30 seconds after exposure to pure methane.

ACCURACY—

±3% 0% to 50% LFL; from 51% to 100% LFL

TEMPERATURE STABILITY—

< ±5% LFL: -13°F to +167°F / -25°C to +75°C

< ±10% LFL: -40°F to -13°F / -40°C to -25°C

TYPICAL SENSOR LIFE—

3 to 5 years, when environment is free of substances and conditions known to be detrimental to catalytic sensing elements and when sensor is operated within specified operating limits.

STORAGE LIFE—

Indefinite if sensor is stored within the specified temperature range and remains in unopened original packaging.

CALIBRATION CYCLE—

30 days after initial calibration and every 90 days thereafter, or as required by the application and environment

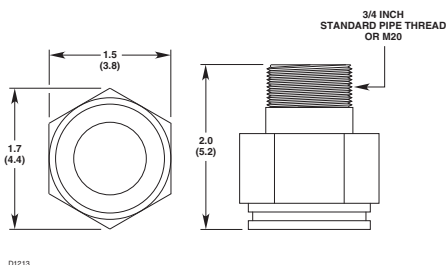

Figure 2—Dimensions of Sensor in Inches (Centimeters)



CGS SENSOR DIMENSIONS—

See Figure 2

CERTIFICATION—

For complete approval details, refer to the appropriate Appendix:

Appendix A – FM

Appendix B – CSA

Appendix C – ATEX

Appendix D - IECEx

Appendix E - Additional Approvals

SIL approval when used with the CTX10

NOTE

Ensure sensor hazardous (classified) location rating is applicable for the intended use.

4.0 INSTALLATION

CAUTION

Always store and transport the sensor in the original factory packaging to ensure proper protection against contamination.

4.1 SENSOR LOCATION

Proper sensor positioning is essential to ensure maximum gas detection capability. Optimum sensor placement and sensor density varies depending upon the conditions at the job site. The system designer and installer must examine the specific area to be protected and identify the most likely leak sources and gas accumulation areas to determine the best sensor locations.

Please note that the sensor must be installed pointing down, ±15° of vertical.

The following factors should be considered for every installation:

- 1. What kind of gas is to be detected?** If it is lighter than air (Acetylene, Hydrogen, Methane, etc.), place the sensor above the potential gas leak. Place it close to the floor for gases that are heavier than air (Benzene, Butane, Butylene, Propane, Hexane, Pentane, etc.) or for vapors resulting from flammable liquid spills. Careful analysis of both the vapor hazard and the application is required — first to determine the feasibility of detection and then to ensure that proper sensor locations are selected.
- 2. How rapidly will the gas diffuse into the air?** Locate the sensor as close as practical to the anticipated source of a gas leak.
- 3. Ventilation characteristics of the immediate area must also be considered.** Air movement can cause the gas to accumulate more heavily in one area than another. Smoke generator tests are useful in identifying typical air current patterns as well as “dead” air spots for both indoor and outdoor applications. The sensors should be placed where the most concentrated accumulation of gas is anticipated.

4. **The sensor should be located in an area where it is safe from potential sources of contamination** that could poison the sensing element.
5. **The sensor should be pointed down** between $\pm 15^\circ$ of vertical to prevent the buildup of contaminants on the gas inlet.
6. **The sensor must be accessible for testing and calibration.**
7. **Exposure to excessive heat or vibration can result in premature failure of electronic devices and should be avoided if possible.** Shielding the transmitter from intense sunlight will reduce solar heating and enhance the service life of the unit.

IMPORTANT

The catalytic gas sensor used with the CTX10 must contact the target gas in order to provide an accurate gas measurement and response. This must always be remembered when selecting locations for gas sensor installation.

5.0 WIRING

5.1 Wire Size and Type

The transmitter is typically connected to the controller/power source using a three conductor

shielded cable. Shielded cable is highly recommended to protect against interference caused by EMI and RFI. Cable shields should be connected to earth ground at the transmitter end only for maximum noise immunity. Shield termination to ground at the controller end only is also acceptable but may offer reduced noise immunity.

The maximum allowable distance between the CTX10 and the output signal receiver (controller) is determined by the wire size used. For the CTX10, a minimum loop resistance of 250 ohms is needed for regulation. The maximum loop resistance is 600 ohms. Calculate the total linear distance and overall resistance of the signal cable. Do not exceed the maximum loop resistance for the CTX10.

Power cable size must be adequate to ensure that no less than the minimum operating voltage is delivered to the transmitter under all operating conditions. Minimum operating voltage for the CTX10 is 18 Vdc. A linear, filtered and regulated 24 Vdc power supply is recommended. Maximum wire size accepted by the CTX10 wire terminals is 12 AWG (2.5 mm²).

In applications where the wiring cable is installed in conduit, the conduit should not be used for wiring to other electrical equipment.

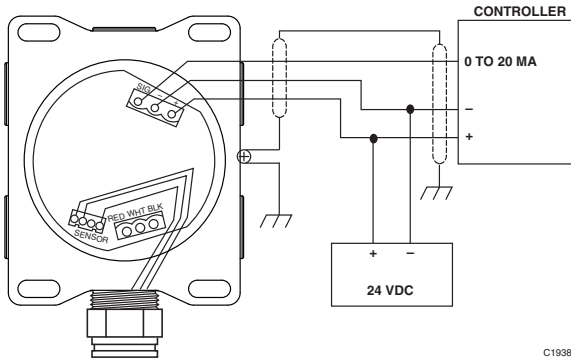

C1938

NOTES:

1. **DO NOT APPLY POWER TO THE TRANSMITTER WITH THE JUNCTION BOX COVER REMOVED UNLESS THE AREA HAS BEEN DE-CLASSIFIED.**
2. **POSITION THE TRANSMITTER WITH THE SENSOR POINTING DOWN.**
3. **THE TRANSMITTER JUNCTION BOX SHOULD BE ELECTRICALLY CONNECTED TO EARTH GROUND.**
4. **ATTACH THE SENSOR TO THE JUNCTION BOX TIGHTLY ENOUGH TO ENSURE AN EXPLOSION-PROOF INSTALLATION, HOWEVER, DO NOT OVERTIGHTEN. LUBRICATE THE THREADS WITH THE CORRECT LUBRICANT TO EASE INSTALLATION AND FUTURE REPLACEMENT. SILICONE BASED LUBRICANTS MUST NEVER BE USED.**
5. **CABLE SHIELDS SHOULD BE CONNECTED TO EARTH GROUND AT BOTH ENDS.**
6. **SHIELDS SHOULD BE STRIPPED BACK FROM CONDUCTORS ONLY WITHIN THE JUNCTION BOX ENCLOSURE.**

Figure 3—CGS Sensor directly mounted to CTX10 Transmitter

NOTE

Either conduit or shielded cable is required.

5.2 CTX10 WIRING

Wire the CTX10 as shown in Figure 3 and Appendix G, page 22.

5.3 SENSOR SEPARATION

For maximum EMI/RFI protection, it is preferable to mount the sensor directly to the CTX10 junction box. However, in many cases it is desirable to locate the sensor in a remote location where early gas detection is most probable and install the transmitter in an easy-access location. In this case, a Sensor Termination Box (Model STB) should be used to install the sensor separately from the transmitter. See Figure 4.

A continuous, three conductor cable with an overall foil shield must be used with the Sensor Termination Box (STB). The cable shield drain wire should be cut back and insulated within the sensor junction box and connected to earth ground at the transmitter junction box. Failure to use a shielded cable or properly ground the shield may result in nuisance alarms caused by EMI/RFI problems.

The maximum separation distance between the sensor and transmitter is limited by the electrical resistance of the connecting wiring, which is a function of the gauge of the wire being used. Maximum sensor transmitter separation with 16 gauge wire is 500 feet/152 meters. Table 2 provides additional distance information.

Wire Size (AWG)	Maximum Transmitter to Sensor Distance	
	Feet	Meters
20	195	59
18	325	99
14 - 16	500	152

Table 2 - Maximum Transmitter to Sensor Distance

6.0 STARTUP

Output loads that are normally actuated by the system should be secured (remove power from all output devices) to prevent undesired activation of these devices.

NOTE

Prior to calibration, it is possible for the transmitter to generate a spurious signal

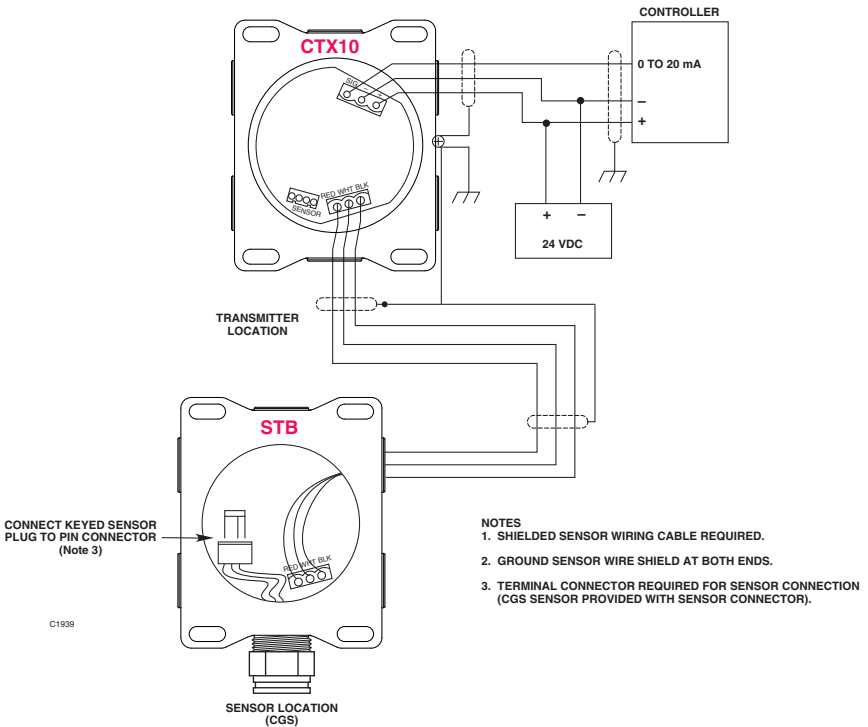

- NOTES**
1. SHIELDED SENSOR WIRING CABLE REQUIRED.
 2. GROUND SENSOR WIRE SHIELD AT BOTH ENDS.
 3. TERMINAL CONNECTOR REQUIRED FOR SENSOR CONNECTION (CGS SENSOR PROVIDED WITH SENSOR CONNECTOR).

Figure 4—CGS direct mounted to STB which is connected to CTX10

output up to 20 mA when power is first applied.

1. Double check all internal and external wiring for proper connections. Check sensor operating voltage if an STB is utilized.
2. If a controller is used, set the alarm set points for the desired levels. (Refer to the controller instruction manual.)
3. Apply power to the CTX10. Allow the transmitter/sensor to stabilize for two hours minimum before calibration for maximum accuracy and repeatability.

NOTE

For highest accuracy, complete a second calibration process after 24 hours.

NOTE

When power is applied to the CTX10, it enters a 15 second time delay before beginning normal operation. This power-up time delay allows time for the sensor to stabilize before the signal output is generated.

4. Calibrate the CTX10 using the Calibration Procedure described below.
5. After calibration is completed, restore the system output loads to ready condition.

7.0 CALIBRATION

The detector must be calibrated upon startup (after warmup) and periodically thereafter to ensure proper performance and gas measurement accuracy. Various factors affect the time interval between periodic calibrations (typically 30, 60, or 90 day intervals, depending on the ambient conditions). Since each application is different, the length of time between regularly scheduled calibrations can vary from one installation to the next. In general, the more frequently a system is checked, the greater the reliability. The detector must be calibrated in these situations:

- Before a new system is initially put into service
- If the sensor is replaced
- If the CTX10 circuit board is replaced.

For maximum calibration accuracy, allow a new sensor to operate under power for several hours (2 hours minimum) to ensure a stable output before performing calibration. For the highest degree of accuracy, perform a second calibration after 24 hours.

For a new system startup, or when gas hazard conditions change within an existing protected area, calibration should be checked frequently, approximately twice in the first month. The calibration data can then be used to determine the optimum interval between periodic calibrations.

Before performing calibration, the operator should ensure that the sensor opening is pointing down and examine the sintered metal cover of the sensor to be sure that it is not missing or damaged. If the cover is defective or missing, the sensor must not be operated, since the exposed sensing element can act as an ignition source. A dirty sintered sensor cover can significantly reduce the sensitivity of the sensor. Dust covers, splash guards, or other sensor accessories may be desirable if ambient conditions result in sensor inlet fouling or blockage.

7.1 CALIBRATION PROCEDURE

As noted earlier, always calibrate at startup, and after replacing either the sensor or transmitter circuit board.

Calibration is initiated by using the magnetic switches (requires magnet tool, Det-Tronics PN 009700-001).

IMPORTANT

Always ensure that the correct gas type is used for calibration. (1.0 LPM flow rate is recommended.)

Calibration is a two-step process consisting of clean air (zero) condition and mid-scale (span) adjustment. Calibration gas must be applied by the operator to enable span adjustment. Calibration gas response should occur in 60 seconds when monitoring the 0-20 mA output.

Calibration using Magnetic Switch and LED

The CTX10 provides an onboard magnetic calibration/reset switch for non-intrusive calibration capability. The magnetic switch is located to the right of the LEDs and identified by this symbol. An onboard yellow LED is provided to signal the operator when to apply and remove calibration gas.



IMPORTANT

If using a k-factor, it must be set prior to calibration. See the table in Appendix F for a list of K-Factors and the corresponding DIP switch settings. **K-Factors below 0.67 are unsupported.**

Step 1: Zero Calibration Initiated (2.2 mA or 3.4 mA) By applying the magnet for more than 1 second the device will enter its calibration sequence. Zero Gas calibration will occur until the zero sensor reading is stable for 15 seconds. Should the stability criteria never be met the calibration will continue for up to 10 minutes before aborting and signaling a Cal Fault (1.6 mA on the 0-20 mA output).

During zero calibration the 0-20 mA loop is held at 2.2 mA in the UD10 and Infiniti modes, and 3.4 mA in the 505 mode. The Yellow Cal LED is on (solid).

NOTE

When the CTX10 is set to the UD10 mode, calibration cannot be initiated via the CTX10 magnetic switch. Calibration can only be initiated via the UD10 menu.

Step 2: Span Calibration Initiated (2.0 or 3.4 mA)

Once the zero calibration completes, the span calibration begins. The span calibration expects 50% of the full scale reading to be applied. All gas readings must be within 2% LEL based on the resultant scaling. When these criteria are met for 15 seconds, the span calibration is calculated and stored in the device. Should the stability criteria never be met, then the calibration will continue for up to 10 minutes before aborting and signaling a Cal Fault (1.6 mA on the 0-20 mA output).

During span calibration the 0-20 mA loop is held at 2.0 mA in the UD10 and Infiniti modes, and 3.4 mA in the 505 mode. The Cal LED will flash at a rate of once every 2 seconds.

Step 3: Calibration Success / Completed (1.8 mA) This state provides up to 5 minutes to remove gas. Once the newly calibrated reading falls below 5% of full scale for more than 5 seconds of readings, the device will return to normal operation (Cal LED turns off).

After a successful calibration, the 0-20 mA loop is held at 1.8 mA until gas is removed or 5 minutes passes. The Cal LED is solid but dim during this phase.

Step 4: Calibration Failure

If there is a calibration fault (1.6 mA), calibrate again after 5 minutes.

Sensor End of Life is indicated during this state. The blue LED will come on for 2 seconds when gas falls below 40% LEL if the sensor has full life. For an End of Life warning (less than 40% of the 100% life remaining), the blue LED will blink throughout this state but turn off upon return to normal mode. If the End of Life threshold of 24% has been reached, then the LED will be solid, and remain solid in normal mode. Cal Fault will be signaled and will require a successful calibration with a more responsive sensor before it will clear, and the blue LED will turn off.

Calibration Aborted (1.6 mA) Should the calibration sequence (including zero and span) exceed 10 minutes before completion, regardless of the reason, the calibration will abort. The device returns to normal operation, but a Cal Fault is signaled.

The 0-20 mA loop is held at 1.6 mA until a successful calibration is taken.

7.2 CALIBRATION USING K-FACTORS

The K-Factor setting adjusts the CTX10 signal output (% LFL reading) to match the LFL percentage of the applied calibration gas. The span setting will vary for different combustible gases. Therefore, calibration should always be performed using the same gas as the one expected to be detected. If the gas or vapor to be detected is not available from Det-Tronics in a calibration gas kit, then a "K-factor" must be used to ensure proper sensitivity to the gas hazard.

Refer to Det-Tronics Technical Note 76-1017 for information and guidance in using K-factors. Also see Appendix F for additional K-Factor and mode setting information.

NOTE

This procedure applies only to the CTX10. Other Det-Tronics transmitters use the standard K-factor formula.

NOTE

Humidity will not impact calibration gas.

SYMPTOM	POSSIBLE CAUSE/S
Controller display shows greater than full scale reading	Over 100% LFL gas at sensor. Take appropriate safety measures. Detector not calibrated. Defective sensor. Power (+) shorted to signal.
No output from transmitter	Power supply failure. Power or signal wiring problem.
Negative % LFL display at controller	No power to transmitter. Detector not calibrated. Sensor not connected. Defective sensor. Wiring problem. Zero Calibration performed with background gas present.
Signal level at controller different than at transmitter	Loose wiring connection. Total signal wiring loop impedance too high. Induced EMI/RFI interference from nearby EMI fields (motors, switches, etc.). Improper earth ground connection of signal wire shield.

Table 3—Troubleshooting Guide

8.0 TROUBLESHOOTING

Table 3 is intended to serve as an aid in locating the cause of a malfunction.

The transmitter is not designed to be repaired in the field. If a problem should develop, first check for proper wiring, calibration and sensor sensitivity. If it is determined that the problem is caused by an electrical malfunction in the transmitter, the unit must be returned to the factory for repair.

9.0 MAINTENANCE

The CTX10 requires no routine maintenance, except for periodic operation to ensure proper calibration. The frequency of these checks is determined by the requirements of the particular installation. Calibration gas kits are required for these checks.

NOTE

Sensor life is displayed via a blue LED on the face of the CTX10 as described below:

Flashing blue LED: Warning, End of Life Approaching

Solid blue LED: End of Life Fault (Continues after gas removal)

Blue LED on for 2 seconds: 2 second blip when gas falls below 40% LFL - Full Sensor Life

9.1 BUMP TESTING

The entire gas detection system should be checked periodically with calibration gas to ensure that the presence of gas at the sensor will result in the proper system response.

NOTE

Life Safety Notifications should be bypassed during the Bump Testing.

9.2 SENSOR INSPECTION

Since a dirty or plugged sensor filter can adversely affect the response time of the sensor by restricting the flow of gas to the sensing element, it should be inspected on a regular basis. If a dust cover or splash shield is used, it should also be checked.

9.3 SENSOR REPLACEMENT

De-classify the area prior to replacing the sensor and secure any output devices connected to the system to prevent unwanted actuation of this equipment.

To replace the sensor:

1. Verify that no hazardous levels of combustible gas are present at the sensor, then remove the cover from the junction box.
2. Unscrew the sensor wires from the circuit board connector and unscrew the sensor from the junction box.
3. Coat the threads of the new sensor with silicone free grease, then screw the sensor into the junction box and screw the sensor wires into the circuit board connector.
4. Allow the sensor output to stabilize under power (about two hours minimum for best results), then perform the calibration procedure described in the "Calibration" section of this manual.

For the highest degree of calibration accuracy, perform a second calibration after 24 hours.

10.0 REPAIR AND RETURN

An adequate supply of spare sensors should be kept on hand for field replacement. For maximum protection against contamination and deterioration, they should not be removed from the original protective packaging until the time of installation.

Always calibrate after replacing either the sensor or the transmitter circuit board.

Prior to returning devices, contact the nearest local Detector Electronics office or visit the Det-Tronics website (www.Det-Tronics.com) so that a Return Material Authorization (RMA) number can be assigned.

A written statement describing the malfunction must accompany the returned device or component to assist in the failure analysis.

Pack the unit properly. Always use sufficient packing material. Where applicable, use an antistatic bag as protection from electrostatic discharge. The RMA number should be clearly marked on the outside of the box.

NOTE

Inadequate packaging that ultimately causes damage to the returned device during shipment will result in a service charge to repair the damage incurred during shipment.

Return all equipment to the factory in Minneapolis.

NOTE

It is highly recommended that a spare be kept on hand for field replacement to ensure continuous protection.

11.0 ORDERING INFORMATION

11.1 SPARE PARTS AND ACCESSORIES

Part Number	Description
009700-001	Magnetic Tool
005003-001	Lubriplate grease, 1 oz.
101197-006	Stop Plug, M20, AL, IP66
101197-007	Stop Plug, M20, SS, Domed
101197-004	Stop Plug, 3/4" NPT, SS
102804-001	Reducer, M25 to M20, AL
101197-001	Stop Plug, 3/4" NPT, AL
013930-001	UD30 CGS Board

11.2 CTX10 MODEL MATRIX

MODEL	DESCRIPTION	
CTX10	Catalytic Combustible Gas Transmitter	
	TYPE	ENCLOSURE MATERIAL
	A	Aluminum
	S	Stainless Steel
	TYPE	CONDUIT ENTRIES AND ORIENTATION
	3	3-port, T-configuration
	TYPE	THREAD TYPE
	F	Metric M20
	M	Metric M25
	N	3/4" NPT
	TYPE	OUTPUT
	2	4-20 mA
	TYPE	APPROVALS
	SA	SIL/FM/CSA
SE	SIL/ATEX/IECEX	
T	SIL/FM/CSA/ATEX/IECEX	

APPENDIX A

FM APPROVAL

THE FOLLOWING CERTIFICATION ITEMS, FUNCTIONS AND OPTIONS DESCRIBE THE FM APPROVAL.

MODEL CTX10 SERIES COMBUSTIBLE GAS TRANSMITTER

FM20US0128X

Class I, Div. 1, Groups B, C & D (T5)

Class I, Div. 2, Groups A, B, C & D (T4)

Tamb -40°C to +75°C

Type 3R

Conduit seal not required

Performance verified in accordance with:

UL FM 60079-29-1: 2019

ANSI/ISA 60079-29-1: 2013

ANSI/ISA-92.00.01: 2010

ANSI/ISA-12.13.04: 2007

FM 6320 (2018)

FM 6325 (2005)

FM 6340 (2014)

ANSI/NEMA 250: 2014

This approval does not include or imply approval of gas detector heads or other apparatus to which the subject instrument may be connected. In order to maintain a Factory Mutual Research approved system, the measurement input signal to which this instrument is connected must also be approved by Factory Mutual Research.

UD30 hazardous location and performance testing was successfully completed down to -40°C.

NOTE

Consideration must be given to overall Gas System Performance Requirements.

NOTE

Model CTX10 must be used in conjunction with an FM Approved control device.

Special Conditions for Safe Use:

1. The apparatus may be used with FM Approved PointWatch Termination Box Model STB, UD10, UD30, or U9500 gas transmitters.
2. Flameproof joints are not user serviceable; contact the manufacturer for details.

APPENDIX B

CSA APPROVAL

THE FOLLOWING CERTIFICATION ITEMS, FUNCTIONS AND OPTIONS DESCRIBE THE CSA APPROVAL.

MODEL CTX10 SERIES COMBUSTIBLE GAS TRANSMITTER

CSA 70192215
CSA C22.2 No. 30
Class I, Div. 1, Groups B, C & D (T5)
Class I, Div. 2, Groups A, B, C & D (T4)
(Tamb = -40°C to +75°C)
Type 3R

Performance verified in accordance with:
CSA No. 60079-29-1: 2017

NOTE

Consideration must be given to overall Gas System Performance Requirements.

NOTE

It is required that calibration of CGS Detector be conducted as well as calibration of the system in which it is installed.



WARNING

Do not open when an explosive atmosphere may be present.



ATTENTION

Ne pas ouvrir quand une atmosphère explosive peut être présente.

NOTE

Conduit seal not required.

REMARQUE

Joint de conduit non requis

APPENDIX C

ATEX APPROVAL

ATEX CERTIFICATION

MODEL CTX10 SERIES COMBUSTIBLE GAS TRANSMITTER

INPUT VOLTAGE—

18 to 30 Vdc

POWER CONSUMPTION—

4.0 watts maximum

⊕ II 2 G

Ex db IIC T5 Gb EN60079-29-1

DEMKO 18 ATEX 2008X

T5 (Tamb = -40°C to +75°C)

IP53

Performance verified in accordance with:

EN 60079-29-1: 2016

Compliance with:

EN 60079-0: 2012+A11:2013

EN 60079-1: 2014

Note: wire must be rated for +93C to comply with EN 60079-0.

General Purpose Gas Detection Performance Certification for Methane and Propane gases per EN 60079-29-1.

Read and understand instruction manual before operating.

Refer to EN 60079-29-2 when performing maintenance.

All cable entry devices and blanking elements shall be certified in type of explosion protection flameproof enclosure “d”, suitable for the conditions of use and correctly installed. Unused apertures shall be closed with suitable certified blanking elements.

For ambient temperatures above -10°C and above +60°C, use field wiring suitable for both minimum and maximum ambient temperatures.

IP ratings do not imply that the CGS will detect gas during and after exposure.

Special Conditions for Safe Use of Model CTX10 Transmitter:

1. The CTX10 gas controller complies with EN 60079-29-1 only when connected to a Detector Head that also has been evaluated to EN 60079-29-1.
2. Response time is determined by the response time of all parts of the gas detection system.
3. Flameproof joints are not intended to be repaired.

CATALYTIC COMBUSTIBLE GAS SENSOR (CGS)

⊕ II 2 G

Ex db IIC T3, T5 Gb EN60079-29-1

DEMKO 02 ATEX 131323X

T5 (Tamb = -40°C to +75°C)

T3 (Tamb = -55°C to +125°C)

EN Standards: EN 60079-0: 2012+A11: 2013
EN 60079-1: 2014
EN 60079-29 -1: 2007

Special Conditions for Safe Use of CGS:

The CGS Combustible Gas Sensor is certified for use in following ambient temperatures:

- ambient temperature range -40°C to $+75^{\circ}\text{C}$

Coding: **Ex db IIC T5 Gb**

- ambient temperature range -55°C to $+125^{\circ}\text{C}$

Coding: **Ex db IIC T3 Gb**

The actual temperature range is marked on the sensor.

The performance ambient temperature rating is limited to -40°C to $+75^{\circ}\text{C}$.

The CGS Combustible Gas Sensor can withstand repeated exposures to 125°C for periods up to 12 hours. It is recommended that the sensor be replaced after maximum 500 hours of exposed to the 125°C temperature condition.

The CGS Combustible Gas Sensor must be used in conjunction with the before mentioned ATEX certified Detector Electronics Corp. combustible gas detector control units for compliance with EN 60079-29-1 standards.

The CGS Combustible Gas Sensor must only be mounted into the enclosures of the UD10, UD30, Infiniti Gas Transmitter Model U9500A Series, the UD10 and UD30 Universal displays, the Combustible Gas Transmitter Model CTX10 Series, the Digital Communication Unit EQ 22xxDCUEX Series, or the Sensor Termination Box Model STB Series.

The actual enclosure must provide a maximum measured reference pressure of 15 bar measured according to EN 60079-1: 2014, §15.

The CGS Combustible Gas Sensor is to be installed in places where there is a low risk of mechanical damage. Flameproof joints are not user serviceable; contact Det-Tronics Service.

SENSOR TERMINATION BOX (STB)

⊕ II 2 G

Ex db IIC T4–T6 Gb EN60079-29-1

DEMKO 02 ATEX 131324X

T6 (Tamb = -55°C to $+60^{\circ}\text{C}$)

T5 (Tamb = -55°C to $+75^{\circ}\text{C}$)

T4 (Tamb = -55°C to $+125^{\circ}\text{C}$)

IP66, IP53 with CGS

EN Standards: EN 50270: 2006
EN 60079-0: 2012+A11: 2013
EN 60079-1: 2007
EN 60529: 2001
EN 60529: 1991+A1: 2000
EN 60079-29-1: 2007

APPENDIX D

IECEX APPROVAL

MODEL CTX10 SERIES COMBUSTIBLE GAS TRANSMITTER

IECEX UL 18.0009X
Ex db IIC T5 Gb
T5 (Tamb = -40°C to +75°C)
IP53

Performance verified in accordance with:
IEC 60079-29-1: 2016

Compliance with:
IEC 60079-0: 2011-16
IEC 60079-1: 2014
IEC 60529, 2.1 ed + Corr. 1: 2003 + 2: 2007

Note: wire must be rated for +93C to comply with IEC 60079-0.

Read and understand instruction manual before operating.

General Purpose Gas Detection performance certification for methane and propane gases per IEC 60079-29-1.

All cable entry devices and blanking elements shall be certified in type of explosion protection flameproof enclosure "d", suitable for the conditions of use and correctly installed. Unused apertures shall be closed with suitable certified blanking elements.

IP ratings do not imply that the CGS will detect gas during and after exposure.

For ambient temperatures above -10°C and above +60°C, use field wiring suitable for both minimum and maximum ambient temperatures.

Special Conditions for Safe Use of Model CTX10 Transmitter:

1. The CTX10 gas controller complies with EN 60079-29-1 only when connected to a Detector Head that also has been evaluated to EN 60079-29-1.
2. Response time is determined by the response time of all parts of the gas detection system.
3. Flameproof joints are not intended to be repaired.

CATALYTIC COMBUSTIBLE GAS SENSOR (CGS)

IECEX ULD 10.0001X
Ex db IIC T3, T5 Gb
T5 (Tamb = -40°C to +75°C)
T3 (Tamb = -55°C to +125°C)

IEC Standards: IEC 60079-0: 2011
IEC 60079-1: 2014

CONDITION OF CERTIFICATION:

The CGS Combustible Gas Sensor is certified for use in following ambient temperatures:

- ambient temperature range -40°C to $+75^{\circ}\text{C}$

Coding: **Ex db IIC T5 Gb**

- ambient temperature range -55°C to $+125^{\circ}\text{C}$

Coding: **Ex db IIC T3 Gb**

The actual temperature range is marked on the sensor.

The CGS Combustible Gas Sensor can withstand repeated exposures to 125°C for periods up to 12 hours. It is recommended that the sensor be replaced after maximum 500 hours of exposed to the 125°C temperature condition.

The CGS Combustible Gas Sensor must only be mounted into the enclosures of the Infiniti Gas Transmitter Model U9500A Series, the UD10 and UD30 Universal Displays, the Combustible Gas Transmitter Model CTX10 Series, the Digital Communication Unit EQ 22xDCUEX Series or the Sensor Termination Box Model STB Series.

The actual enclosure must provide a maximum measured reference pressure of 15 bar measured according to IEC 60079-1: 2007, §15.

The CGS Combustible Gas Sensor is to be installed in places where there is a low risk of mechanical damage.

Flameproof joints are not user serviceable; contact Det-Tronics Service.

SENSOR TERMINATION BOX (STB)

IECEX ULD 10.0007

Ex db IIC T4–T6 Gb

T6 (Tamb = -55°C to $+60^{\circ}\text{C}$)

T5 (Tamb = -55°C to $+75^{\circ}\text{C}$)

T4 (Tamb = -55°C to $+125^{\circ}\text{C}$)

IP66, IP53 with CGS

IEC Standards: IEC 60079-0: 2011

IEC 60079-1: 2007

IEC 60529, 2.1.ed.+Corr. 1: 2003+2: 2007

APPENDIX E

ADDITIONAL APPROVALS

Exida SIL2

INMETRO Brazil

UL-BR 21.0943X

Ex db IIC T5 Gb

T5 (Tamb = -40°C to +75°C)

IP53

APPENDIX F

DIP SWITCH SETTINGS AND K-FACTOR TABLE

REGARDING THE DIP SWITCH AND THE K-FACTORS

IMPORTANT

Set the K-Factor before initiating calibration described in Section 7.0.

DIP switches are labeled per figure below. "UP" is "ON" and "DOWN" is "OFF". Setting these switches using the table on the next page controls the K-Factor and mode.

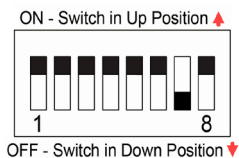

NOTE

The switches should be set to "1.00" as default. That configuration is shown below.

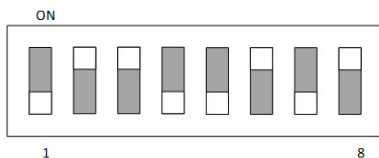

NOTE

Refer to Det-Tronics Technical Note 76-1017 for information and guidance in using non-certified K-factors.

K-FACTOR TABLE

SW 1-6				
1=0n	K-factor	1=0n	K-factor	
111111	1.00000	111110	1.224285548	
011111	Unsupported	011110	1.260124148	
101111		101110	1.296966653	
001111		001110	1.33493289	
110111		110110	1.373963546	
010111		010110	1.414120195	
100111		100110	1.455435319	
000111		000110	1.497942341	
111011		111010	1.541675644	
011011		011010	1.586670606	
101011		101010	1.632963624	
001011		001010	1.680592146	
110011		0.685378825	110010	1.7295947
010011		0.705670547	010010	1.780010924
100011		0.726547662	100010	1.831881602
000011	0.74802706	000010	1.885248693	
111101	0.770126116	111100	1.940155368	
011101	0.792862705	011100	1.996646041	
101101	0.816255221	101100	2.054766408	
001101	0.840322585	001100	2.114563486	
110101	0.865084267	110100	2.176085645	
010101	0.890560296	010100	2.239392652	
100101	0.916771282	100100	2.30450571	
000101	0.943738427	000100	2.371507497	
111001	0.971483544	111000	2.440442214	
011001	1.000029078	011000	2.511385624	
101001	1.02939812	101000	2.584335097	
001001	1.059614428	001000	2.658409661	
110001	1.090702443	110000	2.736650045	
010001	1.122687314	010000	2.816118731	
100001	1.155594914	100000	2.897880003	
000001	1.189451863	000000	2.982	

SW 7: OFF => DEFAULT (DO NOT CHANGE)

SW 8: NA if K-Factor = 1 is Selected

ON => 505 mode (Fixed 3.4mA cal output)

OFF => Infiniti mode (2.2, 2.0, 1.8mA cal sequence)

APPENDIX G

CTX10 with CGS GAS SENSOR

NOTE

The CGS is not approved for stand-alone use. Only use according to the Approval data in this manual. Also see Section 5.3 Sensor Separation for proper installation.

WIRING

CTX10 w/CGS Board Power Cable Distance with Maximum Sensor Separation of 500 Feet Connected Remotely to a Sensor Termination Box (STB).

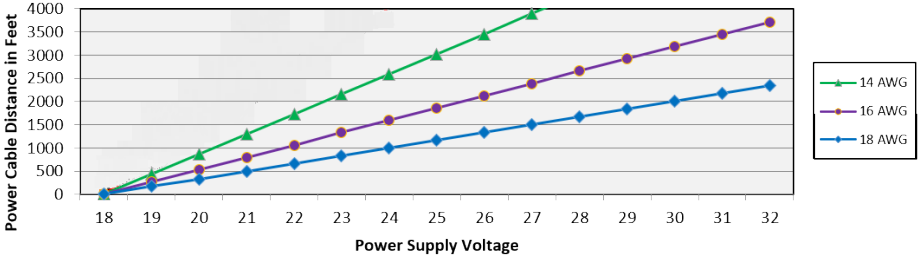

Recommended maximum cable length from the power source to the CTX10 is 2000 feet or 609.9 meters. Recommended maximum cable length from the CTX10 to the sensor is 500 feet or 152 meters for 16 AWG wire.

CTX10 with 18 Volt Power Supply Voltage

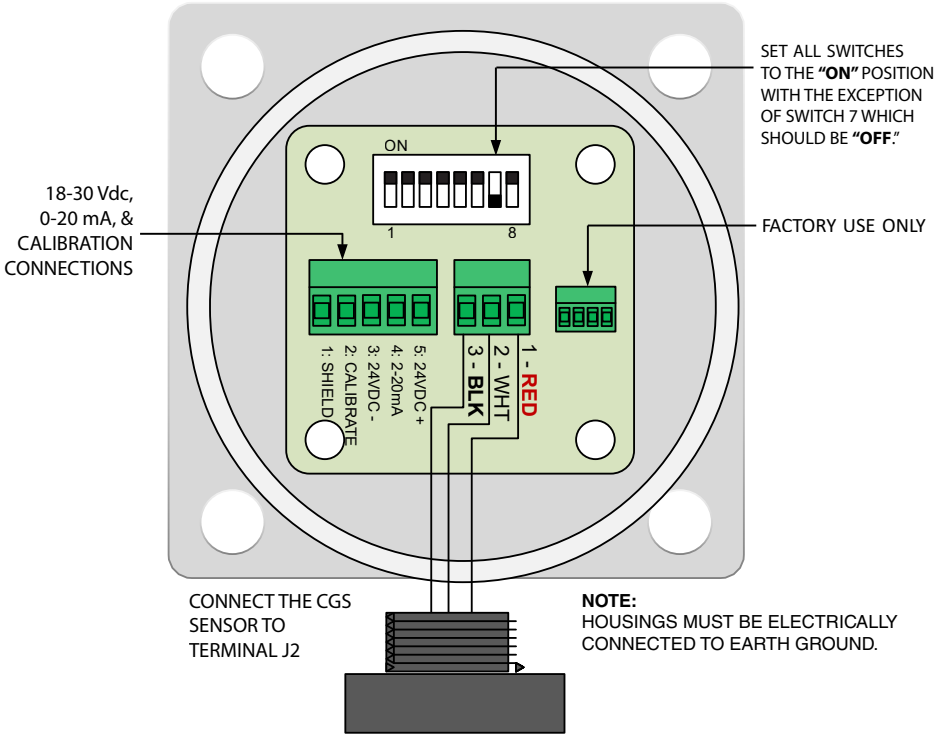



95-8789



FlexSonic® Acoustic
Leak Detector



X3301 Multispectrum
IR Flame Detector



PointWatch Eclipse® IR
Combustible Gas Detector



FlexVu® Universal Display
with GT3000 Toxic Gas Detector



Eagle Quantum Premier®
Safety System

Specifications subject to change without notice.

All trademarks are the property of their respective owners.

© 2021 Carrier All Rights Reserved.



Corporate Office
6901 West 110th Street
Minneapolis, MN 55438 USA
www.det-tronics.com

Phone: +1 952.941.5665
Toll-free: +1 800.765.3473
Fax: 952.829.8750
det-tronics@carrier.com