

Instructions

UV Flame Detector with Pulse Output

X2200, X2200G, X2200M



Table of Contents

DESCRIPTION	1	TROUBLESHOOTING	16
Outputs	1		
LED	2	MAINTENANCE	17
oi (Optical Integrity)	2	Cleaning Procedure	17
Communication	3	oi Plate Removal and Replacement	17
Data Logging	3	Periodic Checkout Procedure	18
Integral Wiring Compartment	3	Clock Battery	18
SIGNAL PROCESSING OPTIONS	3	FEATURES	18
GENERAL APPLICATION INFORMATION	4	SPECIFICATIONS	18
Response Characteristics	4		
False Alarm Sources	4	REPLACEMENT PARTS	20
Factors Inhibiting Detector Response	4	Replacement Parts List	20
IMPORTANT SAFETY NOTES	5	DEVICE REPAIR AND RETURN	20
INSTALLATION	6	ORDERING INFORMATION	20
Detector Positioning	6	Accessories	20
Detector Orientation	6	X2200 Model Matrix	21
Protection Against Moisture Damage	7		
Wiring Procedure	7	APPENDIX A – FM APPROVAL AND	
Setting Device Network Addresses		PERFORMANCE REPORT	22
(EQ and EQP Models Only)	15		
 		APPENDIX B – CSA APPROVAL	26
STARTUP PROCEDURE	15		
Fire Alarm Test	15	APPENDIX C – ATEX APPROVAL	27
		APPENDIX D – IECEx APPROVAL	29

AUTOMATIC

**UV Flame Detector
with Pulse Output
X2200, X2200G, X2200M****IMPORTANT**

Be sure to read and understand the entire instruction manual before installing or operating the flame detection system. Any deviation from the recommendations in this manual may impair system performance and compromise safety.

ATTENTION

*The X2200 includes the Automatic **oi**[®] (Optical Integrity) feature — a calibrated performance test that is automatically performed once per minute to verify complete detector operation capabilities. **Testing with an external test lamp is not approved or required.***

DESCRIPTION

The X2200, X2200G, X2200M UV Flame Detector meets the most stringent requirements worldwide with advanced detection capabilities and immunity to extraneous sources, combined with a superior mechanical design. The detector is equipped with both automatic and manual **oi** test capability.

The X2200 with pulse/relay output is designed for use in controller based systems. In addition to use in new systems, it can serve as a direct field replacement for Detector Electronics Corporation's (Det-Tronics) controller based flame detectors that generate a pulse output (not compatible with R7484 and R7409B/C).

When used as a field replacement, all operating features of the current controller are retained in addition to gaining the advanced features of the X2200 Flame Detector. In typical applications, the four wire X2200 can utilize all existing system wiring.



The detector has Division and Zone explosion-proof ratings and is suitable for use in indoor and outdoor applications. The X2200 housing is available in copper-free aluminum or stainless steel, with NEMA/Type 4X and IP66/IP67 rating.

A tri-color LED on the detector faceplate indicates normal condition and notifies personnel of fire alarm or fault conditions.

OUTPUTS**Relays**

The detector is furnished with fire and fault relays. The relays are rated 5 amperes at 30 Vdc.

The Fire Alarm relay has redundant terminals and normally open / normally closed contacts, normally de-energized operation, and latching or non-latching operation.

The Fault relay has redundant terminals and normally open contacts, normally energized operation, and latching or non-latching operation.

Latching relays can be reset by removing input power (0.1 second minimum).

An alarm condition will normally over-ride a fault condition, unless the nature of the fault condition impairs the ability of the detector to generate or maintain an alarm output, i.e., loss of operating power.

LED

A tri-color LED on the detector faceplate indicates normal condition and notifies personnel of fire alarm or fault conditions. Table 1 indicates the condition of the LED for each status.

Table 1—Detector Status Indicator

Detector Status	LED Indicator
Power On/Normal Auto oi (no fault or fire alarm)	Green
Power On/Normal Man oi	Green, flashing off for 0.5 sec. every 5 sec.
Fault	Yellow
Pre-Alarm/Background UV	Red, flashing on for 1 sec. and off for 1 sec.
Fire (Alarm)	Steady Red
On Power-Up, The LED Flashes in Sequence as Follows, Indicating Sensitivity and Signal Processing Status	
Low UV Sensitivity	One Red Flash
Medium UV Sensitivity	Two Red Flashes
High UV Sensitivity	Three Red Flashes
Very High UV Sensitivity	Four Red Flashes
Stand. UV Signal Process.	One Yellow Flash
Arc Rej. UV Signal Process.	Two Yellow Flashes

ATTENTION

The X2200 contains a source tube that is filled with a gas mixture containing Krypton 85 (Kr⁸⁵), a radioactive material. Radioactive materials are subject to regulation under U.S. and international law. Not applicable to model X2200G, which does not contain Kr⁸⁵.

oi (OPTICAL INTEGRITY)

Automatic oi

The X2200, X2200G, and X2200M include the Automatic **oi** feature — a calibrated performance test that is automatically performed once per minute to verify complete detector operation capabilities. No testing with an external test lamp is required. The detector automatically performs the same test that a maintenance person with a test lamp would perform — once every minute, 60 times per hour. However, a successful Automatic **oi** test does not produce an alarm condition.

The detector signals a fault condition when less than half of the detection range remains. This is indicated by the Fault output and is evident by the yellow color of the LED on the face of the detector. See the “Troubleshooting” section for further information.

Magnetic oi / Manual oi

CAUTION

These tests require disabling of all extinguishing devices to avoid release resulting from a successful test.

The detector incorporates both Magnetic **oi** (Mag **oi**) and Manual **oi** (Man **oi**) test capabilities. These tests provide pulses (80 to 100 CPS) to the controller (R7404 or R7494) when the detector is not in fault. If the test is successful, the controller indicates a fire and the appropriate zone output is active.

NOTE

*If the detector is in a fault condition, a successful Mag **oi** or Man **oi** test cannot be performed.*

The Mag **oi** test is performed by placing a magnet by the location marked “MAG OI” on the outside of the detector (see Figure 2). This action causes the detector to immediately send pulses to the controller. Controller response is as follows:

- The Zone LED blinks.
- The digital display indicates which Zone is in alarm.
- The status indicator shows “6” (fire).

IMPORTANT

*Mag **oi** can be performed with the controller's (R7404/R7494) keylock switch in either the NORMAL or TEST position. In NORMAL, the controller goes into alarm and activates its outputs. If no controller alarm output is desired, place the keylock switch in the TEST position before touching the magnet to the outside of the detector. Man **oi** operates only with the keylock switch in the TEST position.*

During the entire test, the detector gives no indication of alarm.

To reset the controller status and alarms, place the keylock switch in RESET. Return the keylock switch to NORMAL when testing is complete.

The Man **oi** test is nearly identical to the Mag **oi** test, except for the manner in which the test is initiated:

- Place the keylock switch on the controller (R7404/R7494) in the TEST position.
- Press the SELECT button to select the appropriate detector for test.
- Press the TEST/ACCEPT button to initiate the test.

Controller and detector responses are identical to the Mag **oi** test described above.

To reset the controller status and alarms, place the keylock switch in RESET. Return the keylock switch to NORMAL when testing is complete.

NOTE

*Refer to Appendix A for FM verification of the **oi** function.*

COMMUNICATION

The X2200 is furnished with an RS-485 interface for communicating status and other information with external devices. The RS-485 supports Modbus protocol, with the detector configured as a slave device.

DATA LOGGING

Data logging capability is also provided. Status conditions such as normal, power down, general and **oi** faults, pre-alarm, fire alarm, time, and temperature are recorded. Each event is time and date stamped, along with the temperature and input voltage. Event data is stored in non-volatile memory when the event becomes active, and again when the status changes. Data is accessible using the Inspector Connector accessory or RS-485.

INTEGRAL WIRING COMPARTMENT

All external wiring to the device is connected within the integral junction box. The detector is furnished with four conduit entries, with either 3/4 inch NPT or M25 threads.

SIGNAL PROCESSING OPTIONS

The UV detector output (measured in counts per second) is compared to the fire threshold (the "sensitivity" setting). If the radiant energy level from the fire exceeds the selected alarm threshold level, the fire alarm output is activated. In every application, it is crucial to ensure that the radiant ultraviolet energy level from the expected fire at the required distance from the detector will exceed the selected sensitivity level.

The UV detector in the X2200 can be programmed for:

- Arc Rejection
- Standard Signal Processing.

Arc Rejection

The Arc Rejection mode enables the detector to prevent nuisance fire alarms caused by UV from short-duration electrical arcs or electrostatic discharge, while maintaining the ability to reliably detect the UV radiation given off by a flame. Typical applications that benefit from arc rejection logic include electrostatic coating processes and uncontrolled environments where transient UV sources can be present, such as many typical outdoor applications. Most false alarm sources have short transient UV signatures, while fire creates a long UV signature over many seconds. Most fires are detected in a few seconds (see response times in Appendix A).

Standard Signal Processing

Standard signal processing is recommended for high-speed suppression systems only. To allow for high-speed operation, the standard processing mode does not incorporate the arc rejection programming. This mode should only be used in a controlled, indoor environment.

GENERAL APPLICATION INFORMATION

RESPONSE CHARACTERISTICS

Response is dependent on the detector's sensitivity setting, arc rejection, and time delay settings. Other factors include distance, type of fuel, temperature of the fuel, and time required for the fire to come to equilibrium. As with all fire tests, results must be interpreted according to an individual application.

See Appendix A for third-party approved fire test results. Additional fire test results are available from Det-Tronics.

Welding

Electric arc welding is a source of intense ultraviolet radiation. UV radiation from arc welding readily scatters and can deflect across significant distances, even when direct obstructions exist. Any open door or window can allow nuisance UV radiation from arc welding to enter an enclosed area.

It is recommended that the system be bypassed during welding operations in situations where the possibility of a false alarm cannot be tolerated. Gas welding mandates system bypass, since the gas torch is an actual fire.

Artificial Lighting

The X2200 should not be located within 3 feet, 0.9 m of artificial lights. Excess heating of the detector could occur due to heat radiating from the lights.

EMI/RFI Interference

The X2200 is resistant to interference by EMI and RFI, and is EMC Directive compliant and CE Marked. It will not respond to a 5 watt walkie-talkie at distances greater than 1 foot, 0.3 m.

FALSE ALARM SOURCES

The UV sensor is solar blind to the ultraviolet component of solar radiation. However, it may respond to sources of UV besides fire, such as arc flash, electric arc welding, grinding metal, lightning, high voltage corona, x-rays, and gamma radiation.

FACTORS INHIBITING DETECTOR RESPONSE

Windows

Glass and Plexiglas windows significantly attenuate UV radiation and must not be located between the detector and a potential flame source. If the window cannot be eliminated or the detector location changed, contact Det-Tronics for recommendations regarding window materials that will not attenuate UV radiation.

Obstructions

Radiation must be able to reach the detector in order for it to respond. Care must be taken to keep physical obstructions out of the line of view of the detector. In addition, UV absorbing gases or vapors must not be allowed to accumulate between the detector and the protected hazard. See Table 2 for a list of these substances.

Smoke

Smoke will absorb UV radiation. If accumulations of dense smoke can be expected to precede the presence of a flame, then detectors that are used in enclosed areas should be mounted on the wall approximately 3 feet, 0.9 m from the ceiling where the accumulation of smoke is reduced.

Detector Viewing Windows

It is important to keep the detector viewing windows as free of contaminants as possible in order to maintain maximum sensitivity. Commonly encountered substances that can significantly attenuate UV radiation include, but are certainly not limited to, the following:

- Silicones
- Oils and greases
- Dust and dirt buildup
- Paint overspray

Table 2—UV Absorbing Gases and Vapors

The following is a partial list of compounds that exhibit significant UV absorption characteristics. These are also usually hazardous vapors. While generally of little consequence in small amounts, these gases can restrict UV detection if they are in the atmosphere in heavy concentrations. It should also be determined whether or not large amounts of these gases may be released as a result of a fire-causing occurrence.

Acetaldehyde	Methyl Methacrylate
Acetone	Alpha-Methylstyrene
Acrylonitrile	Naphthalene
Ethyl Acrylate	Nitroethane
Methyl Acrylate	Nitrobenzene
Ethanol	Nitromethane
Ammonia	1-Nitropropane
Aniline	2-Nitropropane
Benzene	2-Pentanone
1,3 Butadiene	Phenol
2-Butanone	Pyridine
Butylamine	Hydrogen Sulfide
Chlorobenzene	Styrene
1-Chloro-1-Nitropropane	Tetrachloroethylene
Chloroprene	Toluene
Cumene	Trichloroethylene
Cyclopentadiene	Vinyl Toluene
O-Dichlorobenzene	Xylene
P-Dichlorobenzene	

If UV-absorbing gases may be a factor in a given application, precautionary measures should be taken. Detectors can be placed closer to the potential hazard area, and/or the sensitivity of the detection system can be increased. Contact the factory for further details.

Substances such as methane, propane, butane, hexane, camphor, and octane are not UV absorbing.

IMPORTANT SAFETY NOTES

WARNING

Do not open the detector assembly in a hazardous area when power is applied. The detector contains limited serviceable components and should never be opened. Doing so could disturb critical optical alignment and calibration parameters, possibly causing serious damage. This type of damage could be undetected and could result in failure to see a fire and/or false alarm.

CAUTION

The wiring procedures in this manual are intended to ensure proper functioning of the device under normal conditions. However, because of the many variations in wiring codes and regulations, total compliance to these ordinances cannot be guaranteed. Be certain that all wiring complies with the NEC as well as all local ordinances. If in doubt, consult the authority having jurisdiction before wiring the system. Installation must be done by a properly trained person.

CAUTION

To prevent unwanted actuation or alarm, extinguishing devices must be disabled prior to performing system tests or maintenance.

CAUTION

The UV flame detectors are to be installed in places where the risk of mechanical damages is low.

ATTENTION

Remove the protective cap from the front of the detector before activating the system.

ATTENTION

Observe precautions for handling electrostatic sensitive devices.

ATTENTION

The source tube is a flame-sealed gas tube containing Neon, Hydrogen, and a trace amount of Krypton 85 (Kr⁸⁵), a radioactive material. The total volume of gas within the tube is 0.6 ml per tube, making the gas mixture inside the tube nonflammable. If the gas envelope is broken, it will not produce a flammable mixture, and the gas immediately disperses into the air and is unlikely to present any type of hazard. Krypton gas and its radioactive isotope are inert and are not absorbed by the body. No special handling measure or personal protection equipment is needed for the UV detectors. Not applicable to model X2200G, which does not contain Kr⁸⁵.

INSTALLATION

NOTE

The recommended lubricant for threads and O-rings is a silicone free grease (p/n 005003-001) available from Det-Tronics. Under no circumstances should a lubricant containing silicone be used.

DETECTOR POSITIONING

Detectors should be positioned to provide the best unobstructed view of the area to be protected. The following factors should also be taken into consideration:

- Identify all high risk fire ignition sources.
- Be sure that enough detectors are used to adequately cover the hazardous area.
- Be sure that the unit is easily accessible for cleaning and other periodic servicing.
- Verify that all detectors in the system are properly located and positioned so that any fire hazards are within both the Field of View (FOV) and detection range of the detector. The Q1201C Laser Aimer is recommended for establishing the detector's FOV. Refer to Appendix A for specific information regarding detector range and FOV.
- The detector should be aimed downward at least 10 to 20 degrees to allow lens openings to drain (see Figure 1). **The detector should be positioned so that its FOV does not cover areas outside the hazardous area.** This will minimize the possibility of false alarms caused by activities outside the area requiring protection.
- The detector must be mounted on a rigid surface in a low vibration area.

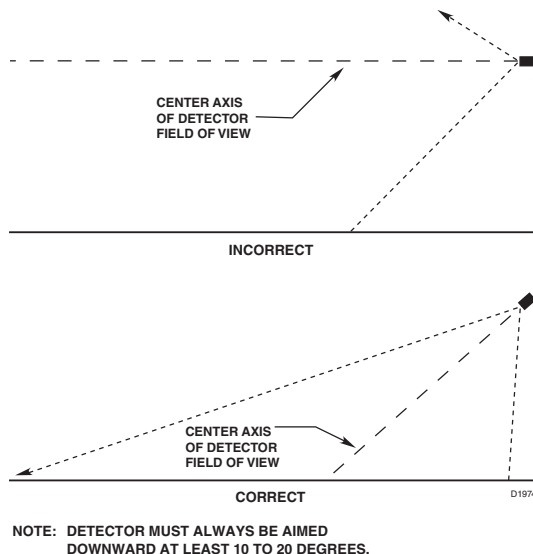

Figure 1—Detector Orientation Relative to Horizon

- Dense fog, rain as well as certain gases and vapors (see Table 2) can absorb UV radiation and reduce the sensitivity of the detector.
- If possible, fire tests can be conducted to verify correct detector positioning and coverage.
- For ATEX/IECEX installations, the X2200 Flame Detector housing must be electrically connected to earth ground.

DETECTOR ORIENTATION

Refer to Figure 2 and ensure that the **oi** plate will be oriented as shown when the X2200 is mounted and sighted. This will ensure proper operation of the **oi** system and will also minimize the accumulation of moisture and contaminants between the **oi** plate and the viewing windows.

IMPORTANT

If removed, the **oi** plate must be securely tightened to ensure proper operation of the **oi** system (40 oz.inches [28.2 N·cm] recommended).

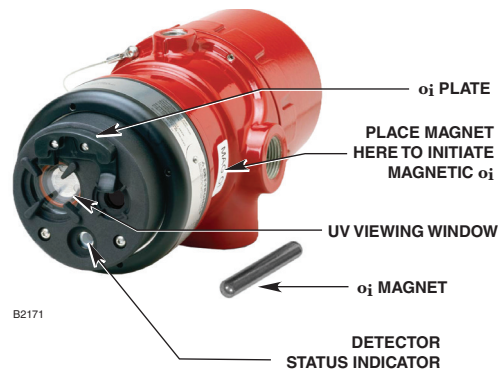

Figure 2—Front View of the X2200

PROTECTION AGAINST MOISTURE DAMAGE

It is important to take proper precautions during installation to ensure that moisture will not come in contact with the electrical connections or components of the system. The integrity of the system regarding moisture protection must be maintained for proper operation and is the responsibility of the installer.

If conduit is used, we recommend installing drains, according to local codes, at water collection points to automatically drain accumulated moisture. It is also recommended to install at least one breather, according to local codes, at upper locations to provide ventilation and allow water vapor to escape.

Conduit raceways should be inclined so that water will flow to low points for drainage and will not collect inside enclosures or on conduit seals. If this is not possible, install conduit drains above the seals to prevent the collection of water or install a drain loop below the detector with a conduit drain at the lowest point of the loop.

Conduit seals are not required for compliance with explosion-proof installation requirements, but are highly recommended to prevent water ingress in outdoor applications. Units with M25 threads must use an IP66/IP67 washer to prevent water ingress.

WIRING PROCEDURE

Wire Size and Type

The system should be wired according to local codes. The wire size selected should be based on the number of detectors connected, the supply voltage, and the cable length. Typically 16 AWG or 2.5 mm² shielded cable is recommended. Wires should be stripped 3/8 inch (9 mm). In some cases where the X2200 is replacing existing pulse output detectors, the wiring and power supplies may not be adequate. Consult the factory for assistance.

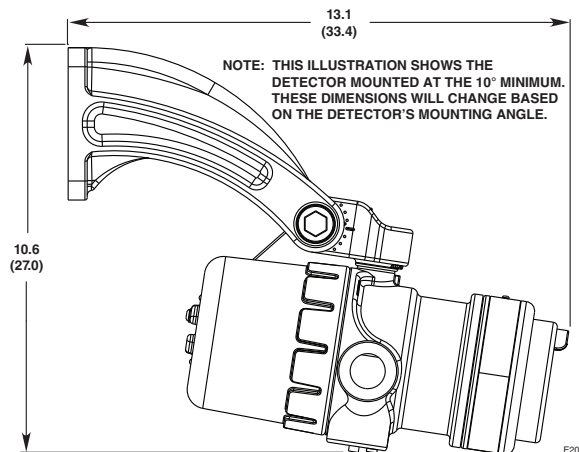
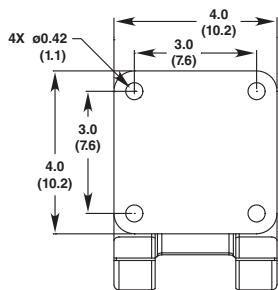

Figure 3—Q9033 Mounting Arm without Collar Attachment Dimensions in Inches (cm)
(See Figure 1 for Correct Detector Orientation.)

IMPORTANT

A minimum input voltage of 18 Vdc must be present at the X2200.

The use of shielded cable is required to protect against interference caused by EMI and RFI. When using cables with shields, terminate the shields as shown in Figures 6 through 10. Consult the factory if not using shielded cable.

The “B” (pulse output) and “D” (oi driver) leads from each detector should be shielded from the “B” and “D” leads of all other detectors in order to prevent false alarms resulting from crosstalk between zones. It is recommended that the “A” and “C” leads also be shielded to provide maximum immunity to EMI/RFI. (See Figures 6 to 10.)

In applications where the wiring cable is installed in conduit, the conduit must not be used for wiring to other electrical equipment.

If disconnection of power is required, separate disconnect capability must be provided.

⚠ WARNING

All entries must contain appropriately rated plugs or fittings. It is required that each plug or fitting be wrench-tightened to an appropriate installation torque and meet the minimum thread engagement requirements per the applicable local standards, codes, and practices in order to retain the defined ratings. PTFE sealant or equivalent should be used.

IMPORTANT

Devices certified for hazardous locations shall be installed in accordance with EN/IECEx 60079-14 and NEC 505

⚠ CAUTION

Installation of the detector and wiring should be performed only by qualified personnel.

Detector Installation

Install the mounting arm assembly on a rigid surface. The ideal installation surface should be free of vibration and suitable to receive 3/8 or M10 bolts with a length of at least 1 inch, 25 mm. The surface must also have sufficient capacity to hold the detector and mounting arm weights (See “Specifications” section). Refer to the Q9033 Mounting Arm manual, number 95-8686, for additional mounting information. See Figure 3 for dimensions.



Figure 4—X2200 Terminal Block

9		19	PULSE OUT	29	SPARE
8		18		28	SPARE
7	COM FIRE	17	COM FIRE	27	
6	N.O. FIRE	16	N.O. FIRE	26	
5	N.C. FIRE	15	N.C. FIRE	25	
4	COM FAULT	14	COM FAULT	24	RS-485 A
3	N.O. FAULT	13	N.O. FAULT	23	RS-485 B
2	+ Vin	12	+ Vin	22	MAN O ₁
1	- Vin	11	- Vin	21	- Vin

D2070

Figure 5—X2200 Pulse Wiring Terminal Identification

Detector Wiring

IMPORTANT

If installing an X2200 in place of an existing detector, be sure to move the “A” Lead (detector power) at the controller from the +290 Vdc source to the +24 Vdc source. **Do not apply 290 Vdc to the X2200.**

1. Make field connections following local ordinances and guidelines in this manual.

Figure 4 shows the wiring terminal strip located inside the detector’s integral junction box.

Figure 5 shows the wiring terminal identification for the X2200 detector with pulse output.

Leave the shield open at the detector end and permanently isolate it from accidental contact with the case and/or other conductors. At the controller/fire panel end, connect the shield and power minus (–) to chassis (earth) ground either directly or through a 0.47 μF 400 Volt non-polarized capacitor (not supplied). (Refer to Figures 6 through 10.)

Figures 11 and 12 provide examples of typical installations with an X2200 wired to a fire alarm panel.

Figure 13 shows an EOL resistor installed within the integral wiring compartment of the detector (refer to the “EOL Resistors” section for details).

2. Check all field wiring to be sure that the proper connections have been made.

IMPORTANT

Do not test any wiring connected to the detector with a meg-ohmmeter. Disconnect wiring at the detector before checking system wiring for continuity.

3. Make the final sighting adjustments and use a 14 mm hex wrench to ensure that the mounting arm assembly is tight.

NOTE: DO NOT CONNECT THE X2200 "A" LEAD (#2/12) TO TERMINAL J1-3 (290 VDC).

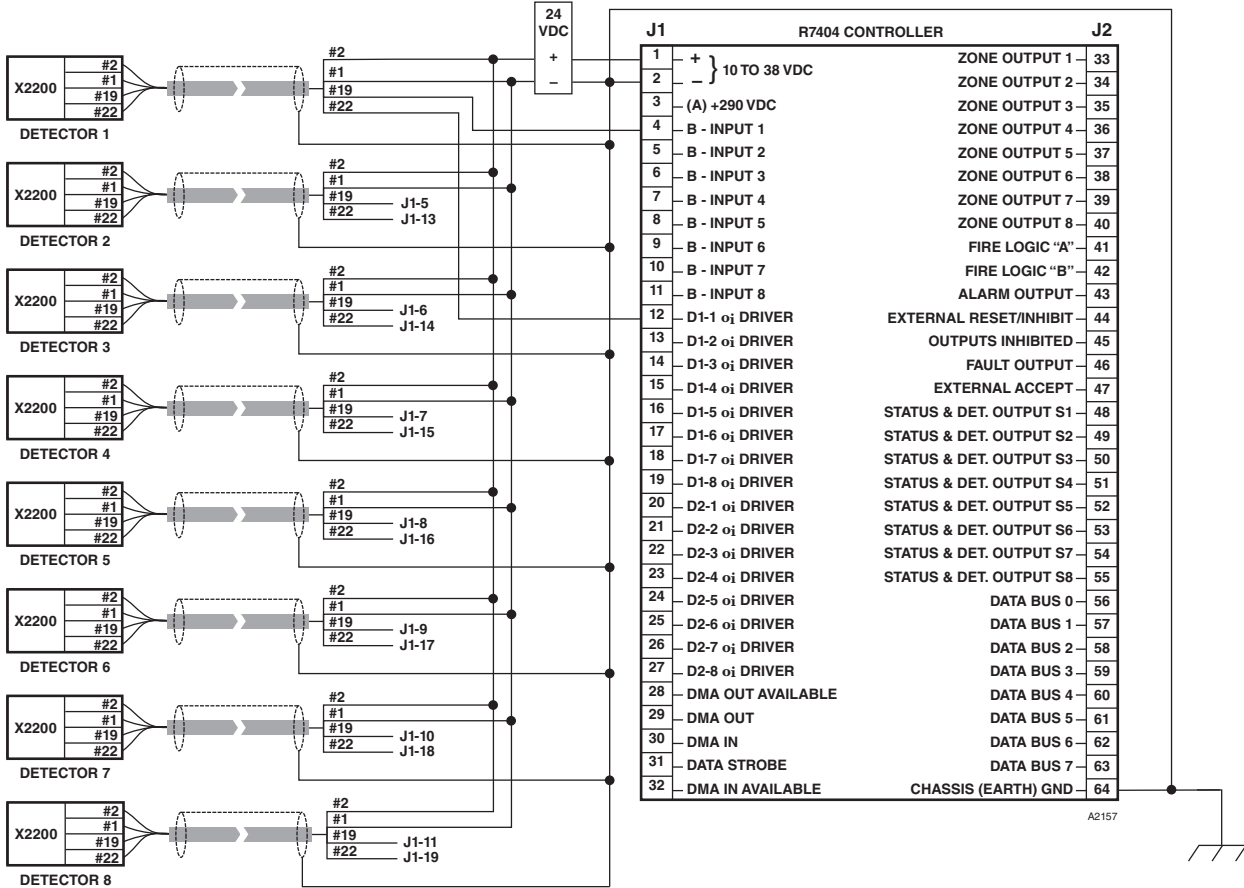

TERMINAL IDENTIFICATION FOR X2200 WITH PULSE OUTPUT.

TERMINAL NO.	FUNCTION
1/11	DC- ("C" LEAD)
2/12	DC+ ("A" LEAD)
19	SIGNAL ("B" LEAD)
22	o _i ("D" LEAD)

NOTE: IF THE POWER SUPPLY MINUS CANNOT BE CONNECTED TO CHASSIS (EARTH) GROUND, CONNECT A 0.47 μF 400 VDC NON-POLARIZED CAPACITOR BETWEEN J1-2 AND J2-64.

NOTE: 2.5 AMPERES @ 24 VDC REQUIRED PER EIGHT DETECTORS.

NOTE: DETECTOR/CONTROLLER CIRCUITS MEET CLASS B, STYLE 0.5 REQUIREMENTS (SIGNALING LINES A AND C).

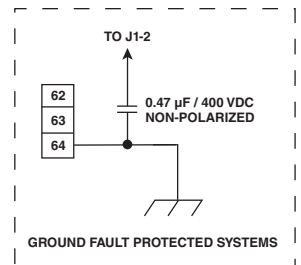
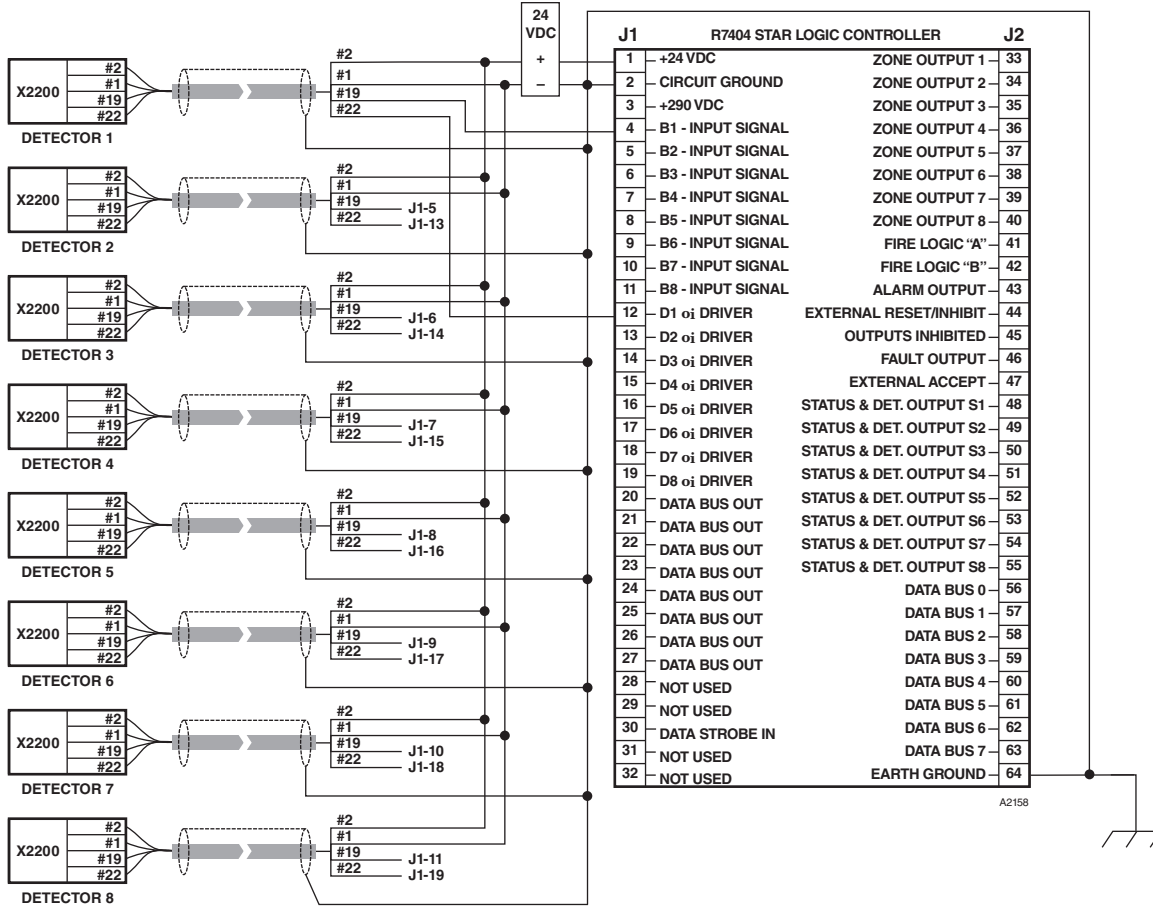

Figure 6—A Typical System, X2200 Detectors Wired to R7404 Controller

NOTE: DO NOT CONNECT THE X2200 "A" LEAD (#2/12) TO TERMINAL J1-3 (290 VDC).



TERMINAL IDENTIFICATION FOR X2200 WITH PULSE OUTPUT.

TERMINAL NO.	FUNCTION
1/11	DC- ("C" LEAD)
2/12	DC+ ("A" LEAD)
19	SIGNAL ("B" LEAD)
22	O _i ("D" LEAD)

NOTE: IF THE POWER SUPPLY MINUS CANNOT BE CONNECTED TO CHASSIS (EARTH) GROUND, CONNECT A 0.47 μF 400 VDC NON-POLARIZED CAPACITOR BETWEEN J1-2 AND J2-64.

NOTE: 2.5 AMPERES @ 24 VDC REQUIRED PER EIGHT DETECTORS.

NOTE: DETECTOR/CONTROLLER CIRCUITS MEET CLASS B, STYLE 0.5 REQUIREMENTS (SIGNALLING LINES A AND C).

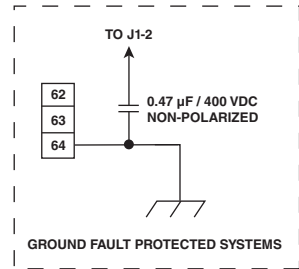
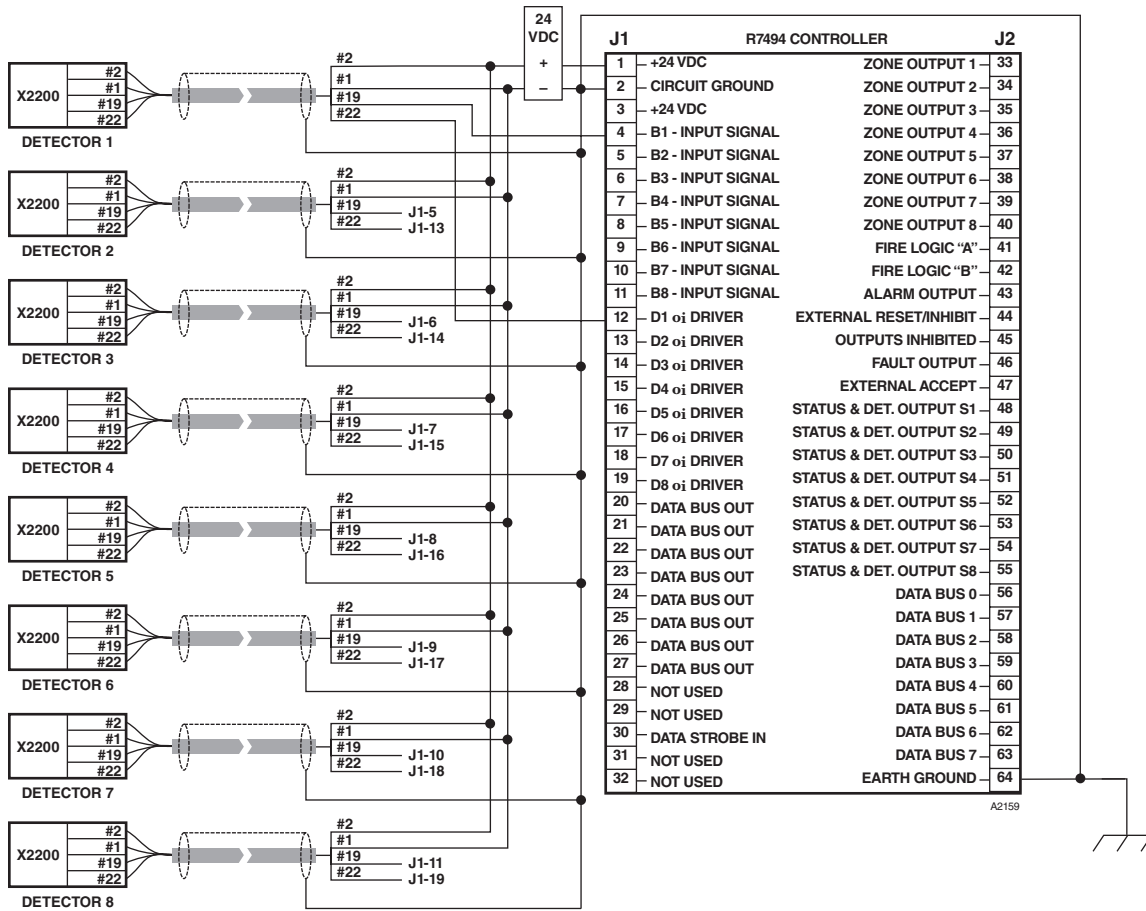

Figure 7—A Typical System, X2200 Detectors Wired to R7404 Star Logic Controller



TERMINAL IDENTIFICATION FOR X2200 WITH PULSE OUTPUT.

TERMINAL NO.	FUNCTION
1/11	DC- ("C" LEAD)
2/12	DC+ ("A" LEAD)
19	SIGNAL ("B" LEAD)
22	oi ("D" LEAD)

NOTE: IF THE POWER SUPPLY MINUS CANNOT BE CONNECTED TO CHASSIS (EARTH) GROUND, CONNECT A 0.47 μF 400 VDC NON-POLARIZED CAPACITOR BETWEEN J1-2 AND J2-64.

NOTE: 2.5 AMPERES @ 24 VDC REQUIRED PER EIGHT DETECTORS.

NOTE: DETECTOR/CONTROLLER CIRCUITS MEET CLASS B, STYLE 0.5 REQUIREMENTS (SIGNALLING LINES A AND C).

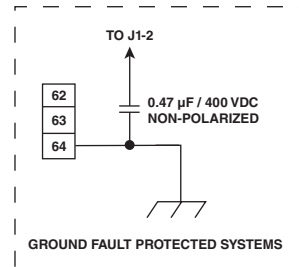

Figure 8—A Typical System, X2200 Detectors Wired to R7494 Controller

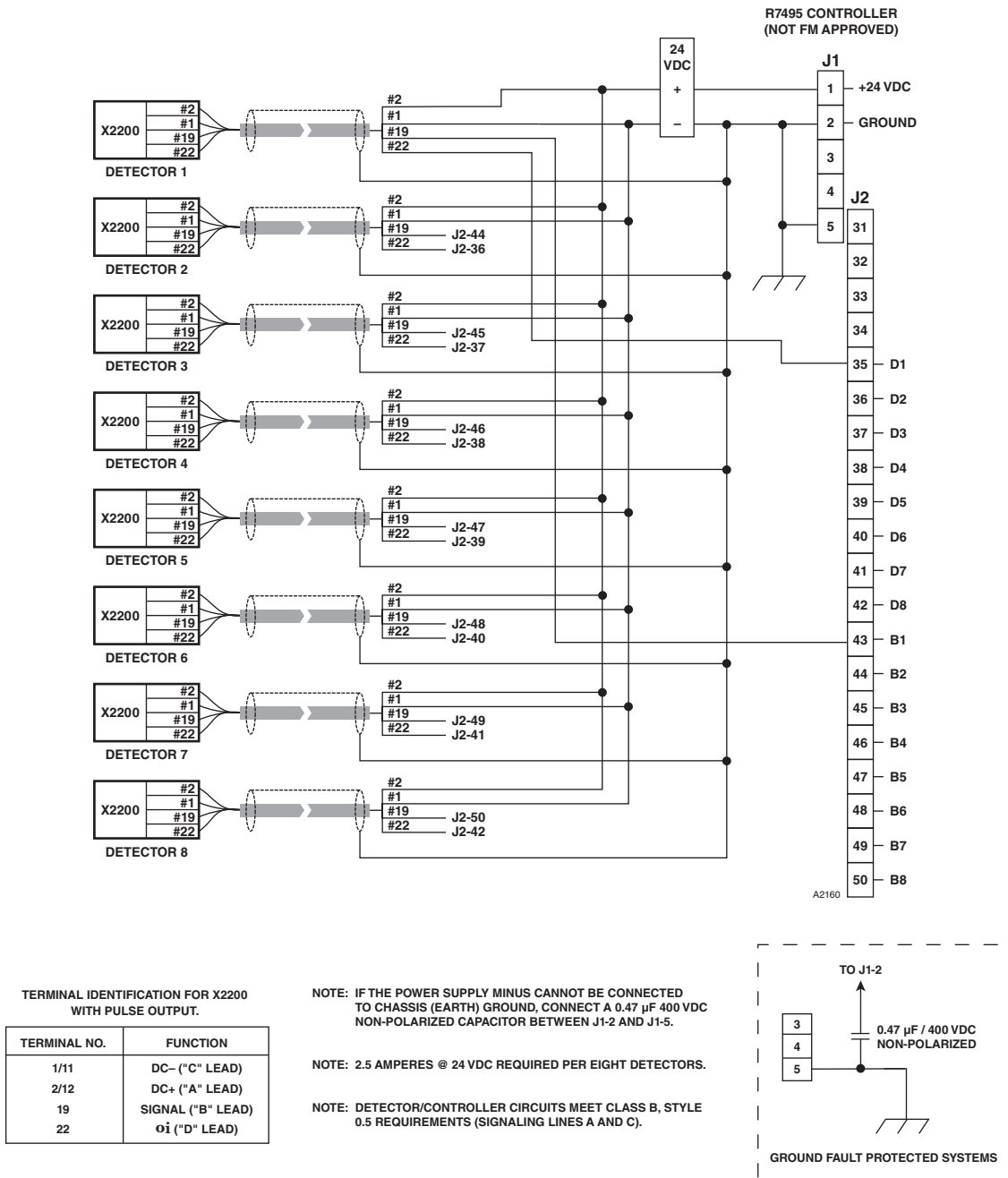
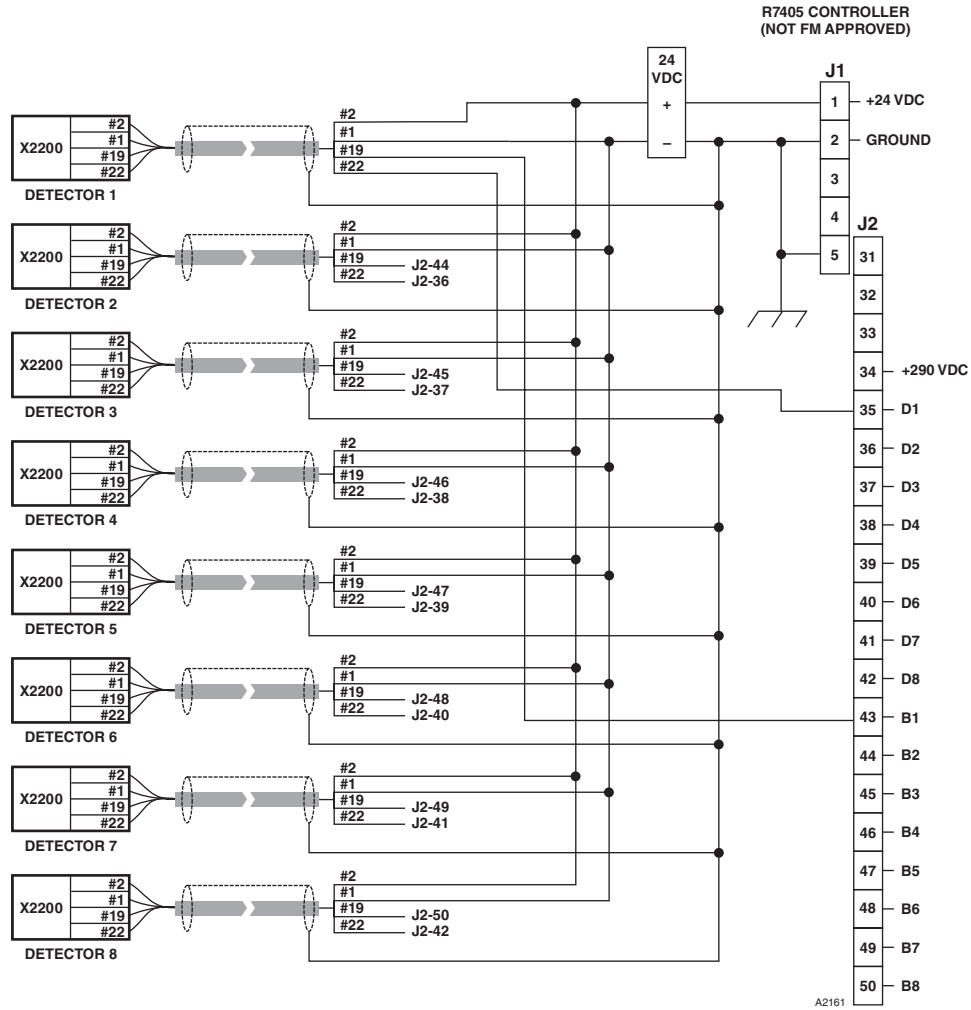

Figure 9—A Typical System, X2200 Detectors Wired to R7495 Controller

NOTE: DO NOT CONNECT THE X2200 "A" LEAD (#2/12) TO TERMINAL J2-34 (290 VDC).



TERMINAL IDENTIFICATION FOR X2200 WITH PULSE OUTPUT.

TERMINAL NO.	FUNCTION
1/11	DC- ("C" LEAD)
2/12	DC+ ("A" LEAD)
19	SIGNAL ("B" LEAD)
22	ϕ_i ("D" LEAD)

NOTE: IF THE POWER SUPPLY MINUS CANNOT BE CONNECTED TO CHASSIS (EARTH) GROUND, CONNECT A 0.47 μ F 400 VDC NON-POLARIZED CAPACITOR BETWEEN J1-2 AND J1-5.

NOTE: 2.5 AMPERES @ 24 VDC REQUIRED PER EIGHT DETECTORS.

NOTE: DETECTOR/CONTROLLER CIRCUITS MEET CLASS B, STYLE 0.5 REQUIREMENTS (SIGNALING LINES A AND C).

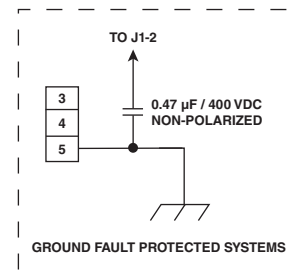
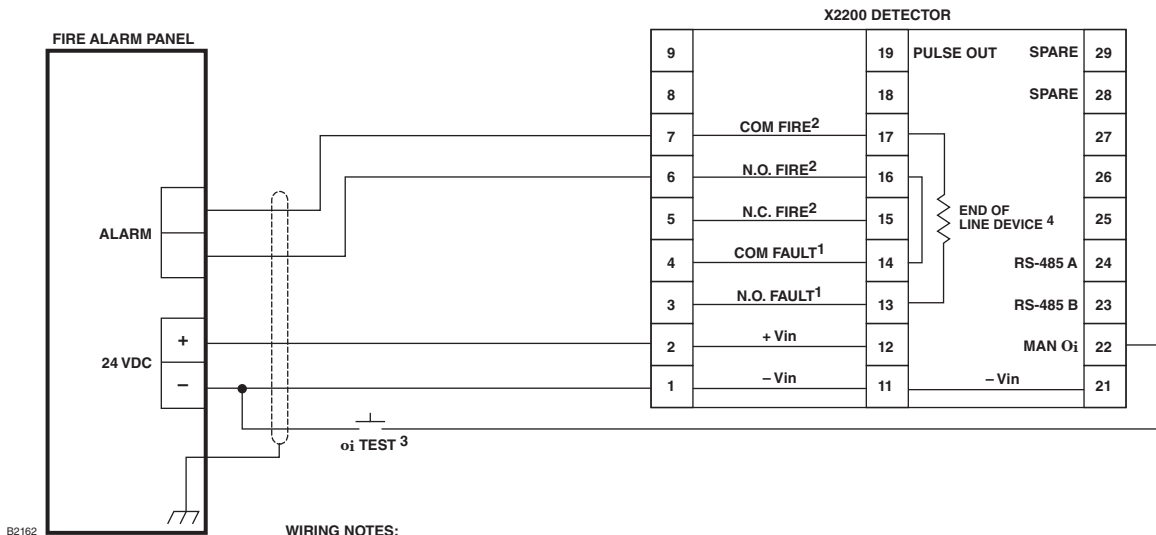

Figure 10—A Typical System, X2200 Detectors Wired to R7405 Controller



WIRING NOTES:

- 1 IN NORMAL OPERATION WITH NO FAULTS OCCURRING, THE FAULT RELAY COIL IS ENERGIZED AND THE CONTACTS ARE CLOSED.
- 2 ALARM RELAY IS NORMALLY DE-ENERGIZED WITH NO ALARM CONDITION PRESENT.
- 3 INDIVIDUAL MANUAL o_i TEST SWITCHES CAN BE INSTALLED REMOTELY OR A DETECTOR SELECTOR AND ACTIVATION SWITCH CAN BE INSTALLED AT THE FIRE PANEL. TEST SWITCHES ARE NOT SUPPLIED. (TEST SWITCHES ARE NOT NEEDED IF MAGNETIC o_i IS USED.)
- 4 REFER TO SPECIFICATIONS SECTION FOR EOL RESISTOR VALUES. REFER TO EOL RESISTORS SECTION FOR INSTALLATION DETAILS.

Figure 11—Ex d Wiring Option

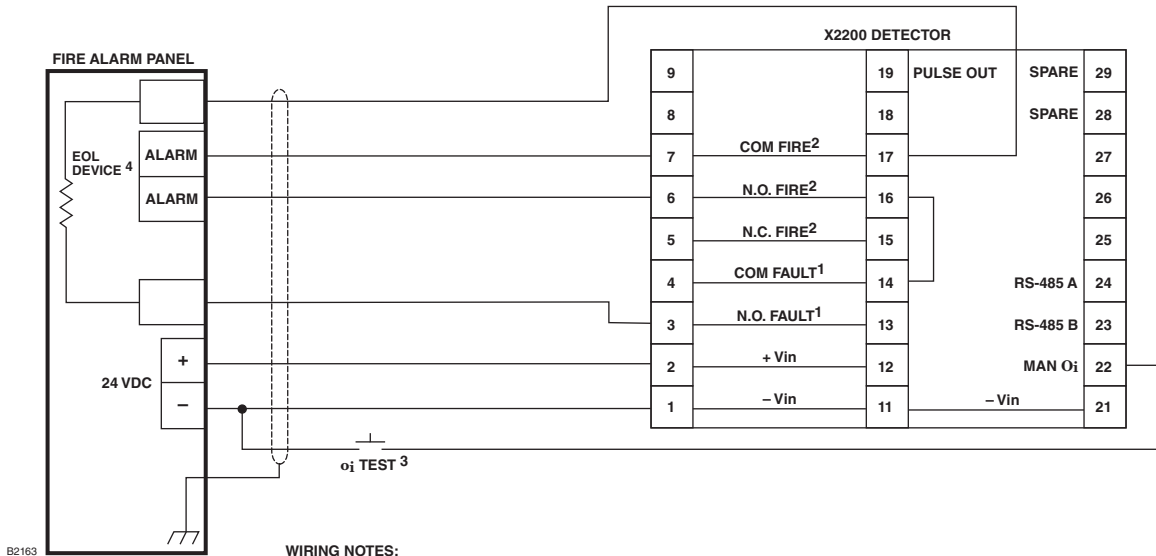

WIRING NOTES:

- 1 IN NORMAL OPERATION WITH NO FAULTS OCCURRING, THE FAULT RELAY COIL IS ENERGIZED AND THE CONTACTS ARE CLOSED.
- 2 ALARM RELAY IS NORMALLY DE-ENERGIZED WITH NO ALARM CONDITION PRESENT.
- 3 INDIVIDUAL MANUAL o_i TEST SWITCHES CAN BE INSTALLED REMOTELY OR A DETECTOR SELECTOR AND ACTIVATION SWITCH CAN BE INSTALLED AT THE FIRE PANEL. TEST SWITCHES ARE NOT SUPPLIED. (TEST SWITCHES ARE NOT NEEDED IF MAGNETIC o_i IS USED.)
- 4 EOL RESISTOR SUPPLIED BY PANEL.

Figure 12—Ex e Wiring Option

EOL RESISTORS

To ensure that the insulating material of the wiring terminal block will not be affected by the heat generated by EOL resistors, observe the following guidelines when installing the resistors.

1. Required EOL resistor power rating must be 5 watts minimum.

NOTE

EOL resistors must be ceramic, wirewound type, rated 5 watts minimum, with actual power dissipation not to exceed 2.5 watts. This applies to ATEX/IECEX installations only.

2. Resistor leads should be cut to a length of approximately 1 1/2 inches, 40 mm.
3. Bend the leads and install the EOL resistor as shown in Figure 13.
4. Maintain a 3/8 inch, 10 mm minimum gap between the resistor body and the terminal block or any other neighboring parts.

NOTE

The EOL resistor can only be used within the flameproof terminal compartment. Unused apertures shall be closed with suitable blanking elements.

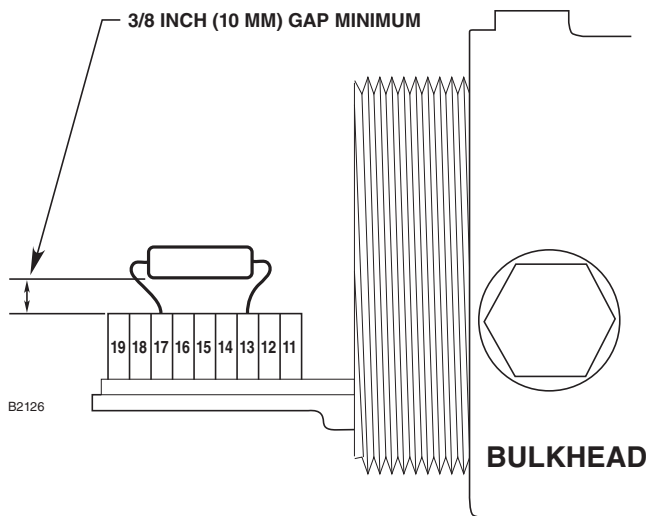

Figure 13—EOL Resistor Installation

STARTUP PROCEDURE

When installation of the equipment is complete, apply power and allow 20 to 30 minutes for the detector's heated optics to reach equilibrium. Then perform one or more of the following tests:

- Man **o_i** Test — Tests detector output and wiring, without generating a fire alarm.
- Count Test Mode — Measures actual detector output to controller (cps), without generating a fire alarm.
- Fire Alarm Test — For complete system test including detector relays. Generates fire alarm output.

MANUAL **o_i** TEST (Output to Controller)

1. Place the keylock switch in the TEST position.
2. Press the SELECT button to display the desired zone on the ZONE indicator on the front panel of the controller.
3. Press and hold the TEST button. The ZONE OUTPUT LED for the tested zone flashes and the SYSTEM STATUS display indicates a "6" (fire condition) if the test is successful.
4. Release the TEST button. The ZONE OUTPUT LED for the tested zone should remain on steadily.
5. Return to step 2 to test the next detector.

If the system responds differently than indicated above, proceed with the count test for the problem zone to verify detector and wiring operation.

COUNT TEST MODE (Output to Controller)

When in the Count Test mode, the frequency of the digital pulses from the detector is displayed on the ZONE and DETECTOR indicators on the controller faceplate. The Count Test mode may be used to check the signal (cps) from a test fire or false alarm source. This can be useful during system set-up for sensitivity and time delay settings. This test is performed in the following manner:

1. Place the keylock switch in the TEST position.
2. Simultaneously press and release the SELECT and TEST buttons. The Status display will change from a "1" to an "8" indicating that the controller is in the Count Test mode of operation.

3. Press the SELECT button until the desired zone is displayed on the ZONE indicator on the controller front panel.
4. Press and hold the TEST button. The DETECTOR/ZONE display indicates the counts per second (cps) received from the detector. If the counts per second exceeds 99, the FIRE LOGIC LEDs are illuminated to indicate that the number shown on the display must be multiplied by 10. **The normal reading for an oi test is 80 to 110 cps. For a live fire test, 270 - 330 cps will be generated.**

A zero reading may indicate a dirty window, **oi** problem, faulty detector, or defective wiring.

Release the Test button, and the ZONE and DETECTOR display should drop to a reading of zero to one counts per second.

FIRE ALARM TEST (Pulse Output to Fire Alarm Panel)

1. Disable any extinguishing equipment that is connected to the system.
2. Apply input power to the system.
3. Initiate a live fire test or a Mag **oi** test. (See "Magnetic **oi** / Manual **oi**" under "Optical Integrity" in the "Description" section of this manual.)
4. Repeat this test for all detectors in the system. If a unit fails the test, refer to the "Troubleshooting" section.
5. Verify that all detectors in the system are properly aimed at the area to be protected. (The Q1201C Laser Aimer is recommended for this purpose.)
6. Enable extinguishing equipment when the test is complete.

TROUBLESHOOTING

WARNING

The sensor module ("front" half of the detector) contains no user serviceable components and should never be tampered with.

1. Disable any extinguishing equipment that is connected to the unit.
2. Inspect the viewing windows for contamination and clean as necessary. (Refer to the "Maintenance" section for complete information regarding cleaning of the detector viewing windows.)
3. Check input power to the unit.
4. Check system and detector logs.
5. Turn off the input power to the detector and check all wiring for continuity. **Important: Disconnect wiring at the detector before checking system wiring for continuity.**
6. If all wiring checks out and cleaning of the **oi** plate/window did not correct the fault condition, check for high levels of background UV radiation by covering the detector with the factory supplied cover or aluminum foil. If the fault condition clears, extreme background UV radiation is present. Re-adjust the view of the detector away from the UV source or relocate the detector.

If none of these actions corrects the problem, return the detector to the factory for repair.

NOTE

It is highly recommended that a complete spare be kept on hand for field replacement to ensure continuous protection.

MAINTENANCE

IMPORTANT

Periodic flamepath inspections are not recommended, since the product is not intended to be serviced and provides proper ingress protection to eliminate potential deterioration of the flamepaths.

⚠ WARNING

To avoid potential electrostatic discharge (ESD), the painted surface of the detector should only be cleaned with a damp cloth.

⚠ WARNING

The sensor module (“front” half of the detector) contains no user serviceable components and should never be tampered with.

To maintain maximum sensitivity and false alarm resistance, the viewing windows of the X2200 must be kept relatively clean. Refer to the following procedure for cleaning instructions.

CLEANING PROCEDURE

⚠ CAUTION

Disable any extinguishing equipment that is connected to the unit to prevent unwanted actuation.

To clean the windows and **oi** plate, use the window cleaner (p/n 001680-001) with a soft cloth, cotton swab, or tissue and refer to the following procedure:

1. Disable any extinguishing equipment that is connected to the unit.

NOTE

Remove input power when cleaning the detector windows. The rubbing motion on the surface of the windows during cleaning can create static electricity that could result in unwanted output activation.

2. Clean the viewing window and reflective surfaces of the **oi** plate using a clean cloth, cotton swab, or tissue with the window cleaning solution. Use Isopropyl alcohol for contaminations that the Det-Tronics window cleaning solution cannot remove. If a fault condition is still indicated after cleaning, remove and clean the **oi** plate using the **oi** Plate Removal and Replacement procedure.

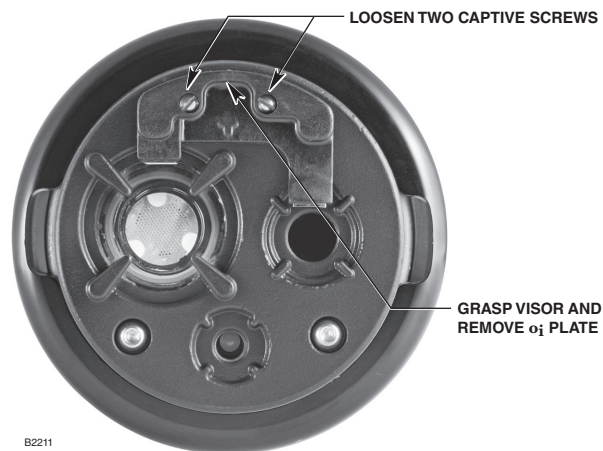

Figure 14—**oi** Plate Removal

IMPORTANT

When used in extreme environments, the reflective surface of the detector **oi** plate may eventually deteriorate, resulting in reoccurring **oi** faults and the need for **oi** plate replacement.

oi PLATE REMOVAL AND REPLACEMENT

1. Disable any extinguishing equipment that is connected to the unit.
2. Loosen the two captive screws, then grasp the **oi** plate by the visor and remove it from the detector. See Figure 14.
3. Install the new (or cleaned) **oi** plate.
4. Recalibrate the detector's **oi** system. Refer to the Inspector Monitor Manual (95-8581) for instructions regarding **oi** plate replacement and **oi** system recalibration.

⚠ CAUTION

Do not replace the **oi** reflector plate without also recalibrating the **oi** system.

Recalibration of the **oi** system requires the use of the Inspector Connector Cable and Inspector Monitor Software. These two items are included in the **oi** replacement kit, or they can be purchased separately. See Ordering Information for details.

PERIODIC CHECKOUT PROCEDURE

A checkout of the system using the Mag **oi** or Man **oi** feature should be performed on a regularly scheduled basis to ensure that the system is operating properly. To test the system, perform the "Manual **oi** Test," "Count Test Mode" or "Fire Alarm Test" as described in the "Startup Procedure" section of this manual.

CLOCK BATTERY

The real time clock has a backup battery that will operate the clock with no external power. Return the device to the factory for battery replacement if needed.

NOTE

If the backup battery is depleted, there is no effect on the operation of the flame detector, but the time stamping of the data log may be affected.

FEATURES

- Responds to a fire in the presence of modulated blackbody radiation (i.e., heaters, ovens, turbines) without false alarm
- High speed capability
- Built-in data logging / event monitoring, up to 1500 events (up to 1000 general, 500 alarms)
- Pulse output for compatibility with controller based systems
- Automatic, manual or magnetic **oi** testing
- Easily replaceable **oi** plate
- Fire and fault relays
- A tri-color LED on the detector faceplate indicates normal condition and notifies personnel of fire alarm or fault conditions
- Operates under adverse weather conditions
- Mounting arm allows easy sighting
- Integral wiring compartment for ease of installation
- Explosion-proof/flame-proof detector housing. Meets FM, CSA, ATEX, and IECEx certification requirements.
- Class A wiring per NFPA-72 (relay connections). (Pulse output is equivalent to class A when detectors are installed in a redundant configuration)
- 3 year warranty
- Advanced signal processing (ARC)
- RFI and EMC Directive Compliant

SPECIFICATIONS

OPERATING VOLTAGE—

24 Vdc nominal (18 Vdc minimum, 30 Vdc maximum).
Maximum ripple is 2 volts peak-to-peak.



For CSA compliance, the power source must utilize a SELV (Safety Extra Low Voltage) or Class 2 style power supply.

POWER CONSUMPTION—

2.5 watts at 24 Vdc nominal;
4.5 watts at 24 Vdc in alarm.
2.8 watts at 30 Vdc nominal;
5.1 watts at 30 Vdc in alarm.

Total power: 7.6 watts at 30 Vdc with EOL resistor installed.
EOL resistor must be ceramic, wirewound type, rated 5 watts minimum, with actual power dissipation not to exceed 2.5 watts.

POWER UP TIME—

Fault indication clears after 0.5 second; device is ready to indicate an alarm condition after 30 seconds.

OUTPUT RELAYS—

Fire Alarm relay, Form C, 5 amperes at 30 Vdc:

The Fire Alarm relay has redundant terminals and normally open / normally closed contacts, normally de-energized operation, and latching or non-latching operation.

Fault relay, Form A, 5 amperes at 30 Vdc:

The Fault relay has redundant terminals and normally open contacts, normally energized operation, and latching or non-latching operation.

TEMPERATURE RANGE—

Operating: -40°F to $+167^{\circ}\text{F}$ (-40°C to $+75^{\circ}\text{C}$).

Storage: -67°F to $+185^{\circ}\text{F}$ (-55°C to $+85^{\circ}\text{C}$).

Hazardous location ratings from -55°C to $+75^{\circ}\text{C}$ available on flameproof model.

HUMIDITY RANGE—

0 to 95% relative humidity, can withstand 100% condensing humidity for short periods of time.

CONE OF VISION—

The detector has a 90° cone of vision (horizontal) with the highest sensitivity lying along the central axis. See Figure 15.

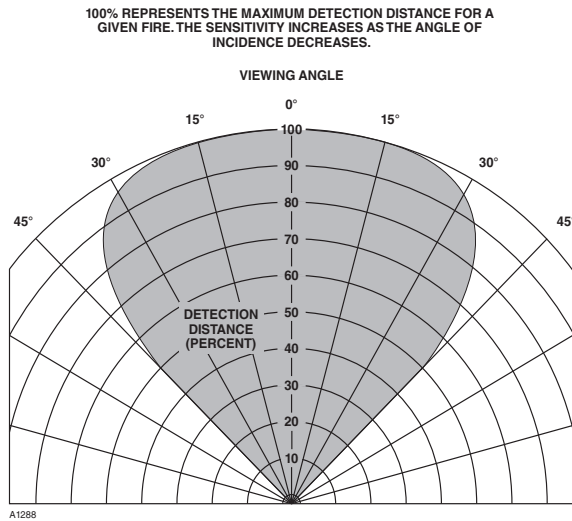

Figure 15—Detector Cone of Vision

RESPONSE TIME—

Typical response times are under 6 seconds. See Appendix A for actual response times.

SOURCE TUBE—

Contains radioactive isotope Krypton 85 (Kr^{85})
 Calculated Activity: 14,800 Becquerels (0.4 μ Ci).
 Note: Not applicable to model X2200G

ENCLOSURE MATERIAL—

Copper-free aluminum (painted) or Stainless Steel (316/CF8M Cast).

VIBRATION—

Conformance per FM 3260: 2000, MIL-STD 810C (Curve AW),

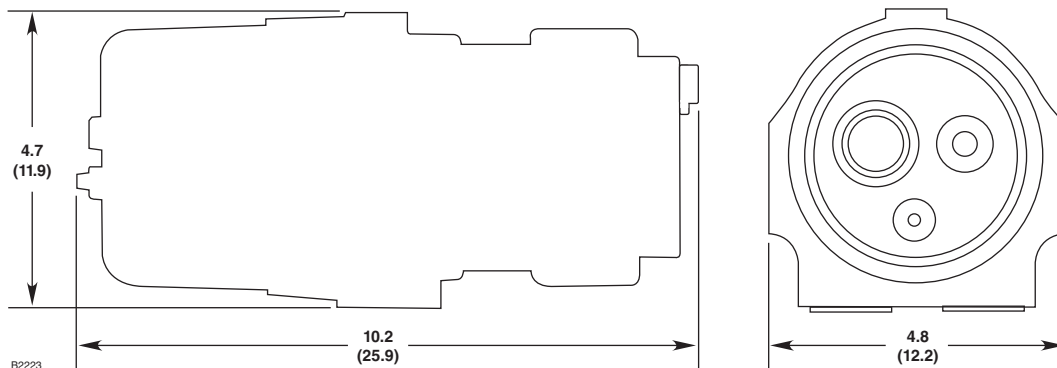

Figure 16—Dimensions in Inches (cm)

DIMENSIONS—

See Figure 16.

WIRING—

Field wiring screw terminals are UL/CSA rated for up to 14 AWG wire, and are DIN/VDE rated for 2.5 mm² wire. Screw terminal required torque range is 3.5–4.4 in.-lbs. (0.4–0.5 N·m).

Important: 18 Vdc minimum must be available at the detector. For ambient temperatures below –10°C (14°F) and above +60°C (140°F) use field wiring suitable for both minimum and maximum ambient temperature.

THREAD SIZE—

Conduit connection: Four entries, 3/4 inch NPT or M25. Conduit seal not required.

SHIPPING WEIGHT (Approximate)—

- Aluminum: 7 pounds (3.2 kilograms).
- Stainless Steel: 14.6 pounds (6.7 kilograms).
- Mounting Arm (AL): 6 pounds (2.75 kilograms).
- Mounting Arm (SS): 14 pounds (6.4 kilograms).

WARRANTY PERIOD—

3 years

CERTIFICATION—



For complete approval details, refer to the appropriate Appendix:

- Appendix A - FM
- Appendix B - CSA
- Appendix C - ATEX
- Appendix D - IECEx

REPLACEMENT PARTS

The detector is not designed to be repaired in the field. If a problem should develop, refer to the "Troubleshooting" section. If it is determined that the problem is caused by an electronic defect, the device must be returned to the factory for repair.

REPLACEMENT PARTS LIST

Part Number	Description
009208-002	oi Replacement kit for X52/X22/X98 (5 Reflector Plates) with Inspector Connector and Monitor
007307-002	Replacement oi Reflector Plate for X52/X22/X98 (requires Inspector Connector to calibrate)

DEVICE REPAIR AND RETURN

Prior to returning devices, contact the nearest local Detector Electronics office so that a Return Material Authorization (RMA) number can be assigned. **A written statement describing the malfunction must accompany the returned device or component to assist and expedite finding the root cause of the failure. When items are being returned, please note:**

NOTE

Shipping personnel must be hazmat trained to pack, mark, and label the return package. Please consult your country-specific regulations.

Pack the unit properly. Always use sufficient packing material. Where applicable, use an antistatic bag as protection from electrostatic discharge.

NOTE

Det-Tronics reserves the right to apply a service charge for repairing returned product damaged as a result of improper packaging.

Return all equipment transportation prepaid to the factory in Minneapolis.

NOTE

It is highly recommended that a complete spare be kept on hand for field replacement to ensure continuous protection.

NOTE

Radioactive material is subject to regulation. All products containing a source tube meet the definition of an "excepted package" for radioactive material under the US Department of Transportation (DOT), the International Air Transport Association (IATA), the International Civil Aviation Organization (ICAO), the International Maritime Dangerous Goods Code (IMDG), and any other specific hazardous material regulations from the country of source of return (TDG, RID, ADR, etc.). These units are classified as "UN2911, Radioactive Material, Excepted Package – Article." Not applicable to model X2200G; not subjected to UN2911 Classification.

ORDERING INFORMATION

When ordering, please specify:

X2200, X2200G, X2200M UV Flame Detector with Pulse Output

Refer to the X2200 Model Matrix for details.

Q9033 mount is required:

Q9033A for aluminum detectors only.

Q9033B for aluminum and stainless steel detectors.

ACCESSORIES

Part Number	Description
000511-029	Converter RS485 to RS232
103881-001	Converter RS485 to USB
007819-001	W6300B1002 Serial Inspector Connector (Inspector Monitor software included)
007819-002	W6300B1003 USB Inspector Connector (Inspector Monitor software included)
009207-001	Flame Inspector Monitor CD
103922-001	Model 475 HART Communicator
102740-002	Magnet
008082-001	Magnet and Adapter for Extension Pole
007739-001	Magnet and Extension Pole
007240-001	Q1116A1001, Air Shield (AL)
007818-001	Q1118A1001 Aluminum Air Shield/Flange Mount (AL)
007818-002	Q1118S1001 Stainless Steel Air Shield/Flange Mount (SS)
009177-001	Q1120A1001 Paint Shield mounting ring (AL)
006097-001	Q1201 Laser
102871-001	Laser Battery, 3V Lithium (laser)
007255-001	Q1201C1001 X-Series Laser Holder (AL/Plastic)
007338-001	Q2000A1001 X-Series Weather Shield (AL)
007290-001	Q9033B Stainless Steel Mounting Arm Assembly is for aluminum and stainless steel detectors
007290-002	Q9033A Aluminum Mounting Arm Assembly is for aluminum detectors only
011385-001	Q9033 Collar Attachment
101197-001	Stop Plug, 3/4" NPT, AL
101197-004	Stop Plug, 3/4" NPT, SS
101197-005	Stop Plug, M25, AL, IP66
101197-003	Stop Plug, M25, SS, IP66
010816-001	Stop Plug, 20 Pack, 3/4" NPT, AL
010817-001	Stop Plug, 20 Pack, 3/4" NPT, SS
010818-001	Stop Plug, 20 Pack, M25, AL, IP66
010819-001	Stop Plug, 20 Pack, M25, SS, IP66
103363-001	14 mm Hex Wrench (Steel)
103406-001	Screwdriver
001680-001	Window cleaner (6 pack)
107427-040	O-ring - Rear Cover (Viton) - black or brown
005003-001	1 oz grease for detectors (silicone-free)
104346-154	O-ring Rear Cover (Fluorosilicone) - blue
012540-001	1 oz PTFE silicone-free lubricant

X2200 MODEL MATRIX

MODEL	DESCRIPTION
X2200	UV Flame Detector
X2200G	UV Flame Detector with KR ⁸⁵ Free Source Tube
X2200M	UV Flame Detector with Molybdenum Tube
TYPE	MATERIAL
A	Aluminum
S	Stainless Steel (316)
TYPE	THREAD TYPE
4M	4 Port, Metric M25
4N	4 Port, 3/4" NPT
TYPE	OUTPUTS
15	Relay and Pulse
TYPE	APPROVALS
W	FM/CSA/ATEX/IECEX
C	CSA
E	ATEX/IECEX
TYPE	CLASSIFICATION
1	Division/Zone Ex d e
2	Division/Zone Ex d

APPENDIX A

FM APPROVAL AND PERFORMANCE REPORT

THE FOLLOWING ITEMS, FUNCTIONS, AND OPTIONS DESCRIBE THE FM APPROVAL:

- Explosion-proof for Class I, Div. 1, Groups B, C, and D (T5) Hazardous (Classified) Locations per FM 3615.
- Dust-ignition proof for Class II/III, Div. 1, Groups E, F, and G (T5) Hazardous (Classified) Locations per FM 3615.
- Nonincendive for Class I, Div. 2, Groups A, B, C, and D (T3) Hazardous (Classified) Locations per FM 3611.
- Nonincendive for Class II, Div. 2, Groups F and G (T3) Hazardous (Classified) Locations per FM 3611.
- Enclosure rating NEMA Type 4X per NEMA 250.
- Ambient Temperature Limits: -40°F to +167°F (-40°C to +75°C).
- Automatic Fire Alarm Signaling Performance verified per FM 3260 (2000).

Flameproof per ANSI/ISA 60079-0, -1, -7, -31
CL I, ZONE 1, AEx db eb IIC T6...T5
T6 (Tamb -40°C to +60°C)
T5 (Tamb -40°C to +75°C)
ZONE 21, AEx tb IIIC T80°C
Tamb -40°C to +75°C
IP66/IP67

CL I, ZONE 1, AEx db IIC T6...T5
T6 (Tamb -40°C to +60°C)
T5 (Tamb -40°C to +75°C)
ZONE 21, AEx tb IIIC T80°C
Tamb -40°C to +75°C
IP66/IP67

The following accessories are FM approved for use with the X2200 Flame Detector:

Part Number	Description
102740-002	Magnet
007739-001	Magnet and Extension Pole
007290-001	Q9033B Stainless Steel Mounting Arm Assembly is for aluminum and stainless steel detectors
007290-002	Q9033A Aluminum Mounting Arm Assembly is for aluminum detectors only
011385-001	Q9033 Collar Attachment

The following performance criteria were verified:

AUTOMATIC OPTICAL INTEGRITY TEST:

The detector generated an optical fault in the presence of contamination on any single or combination of lens surfaces resulting in a loss of approximately 50% of its detection range, verifying that the detector performs a calibrated Automatic **oi** test for each sensor. Upon removal of the contamination, the detector fault was cleared and the detector was verified to detect a fire.

MANUAL OPTICAL INTEGRITY TEST:

The Manual / Magnetic **oi** performs the same calibrated test as the Automatic **oi**, and additionally actuates the alarm relay to verify output operation. If there is a 50% loss of its detection range, an alarm signal is not generated.

The **oi** test procedure, as described in the "Magnetic **oi** / Manual **oi**" section of this instruction manual, is the approved external optical test method for this detector to verify end-to-end detector function. This test replaces the function and need of a traditional external test lamp.

FM Approval and Performance Report – Continued

RESPONSE CHARACTERISTICS

Very High Sensitivity

Fuel	Size	Distance feet (m)	Typical Response Time (seconds)	Mode
n-Heptane	1 x 1 foot	85 (25.9)	3	Low Arc
Methane	32 inch plume	100 (30.5)	2	Low Arc

High Sensitivity

Fuel	Size	Distance feet (m)	Typical Response Time (seconds)	Mode
n-Heptane	1 x 1 foot	60 (18.3)	2	Standard
n-Heptane	1 x 1 foot	60 (18.3)	2	Hi Arc
n-Heptane	1 x 1 foot	60 (18.3)	7	Very Hi Arc
Methane	32 inch plume	70 (21.3)	2	Standard
Methane	32 inch plume	70 (21.3)	2	Hi Arc
Methane	32 inch plume	70 (21.3)	2	Very Hi Arc

Medium Sensitivity

Fuel	Size	Distance feet (m)	Typical Response Time (seconds)	Mode
n-Heptane	1 x 1 foot	35 (10.6)	2	Standard
n-Heptane	1 x 1 foot	50 (15.2)	3	Hi Arc
Methane	1 x 1 foot	55 (16.8)	2	Standard
Methane	32 inch plume	55 (16.8)	2	Hi Arc

RESPONSE CHARACTERISTICS IN THE PRESENCE OF FALSE ALARM SOURCES

Very High Sensitivity (Standard Mode)

False Alarm Source	Distance feet (m)	Fire Source	Distance feet (m)	Typical Response Time (seconds)
Sunlight, direct, modulated, reflected	—	6-inch propane	10 (3)	<30
6 kw heater, modulated & unmodulated	10 (3)	1 x 1 foot n-Heptane	75 (22.9)	1
250 w vapor lamp, modulated & unmodulated	3 (0.9)	1 x 1 foot n-Heptane	75 (22.9)	1
300 w incandescent lamp, modulated & unmodulated	3 (0.9)	1 x 1 foot n-Heptane	75 (22.9)	1
1500 w electric radiant heater, modulated & unmodulated	10 (3)	1 x 1 foot n-Heptane	75 (22.9)	1
2-34 w fluorescent lamps, modulated & unmodulated	3 (0.9)	1 x 1 foot n-Heptane	75 (22.9)	1

FALSE ALARM IMMUNITY

Very High Sensitivity (Standard Mode)

False Alarm Source	Distance feet (m)	Modulated Response	Unmodulated Response
Sunlight, direct, modulated, reflected	—	No Alarm	No Alarm
Vibration	N/A	No Alarm	No Alarm
6 kw heater	3 (0.9)	No Alarm	No Alarm
250 w vapor lamp	3 (0.9)	No Alarm	No Alarm
300 w incandescent lamp	3 (0.9)	No Alarm	No Alarm
1500 w electric radiant heater	3 (0.9)	No Alarm	No Alarm
2-34 w fluorescent lamps	3 (0.9)	No Alarm	No Alarm

FM Approval and Performance Report – Continued

FIELD OF VIEW

Very High Sensitivity

Fuel	Size	Distance feet (m)	Horizontal (degrees)	Typical Response Time (seconds)	Vertical (degrees)	Typical Response (seconds)	Mode
n-Heptane	1 x 1 foot	42.5 (13)	+45 -45	2 2	+45 -30	2 2	Low Arc
Methane	32 inch plume	50 (15.2)	+45 -45	2 2	+45 -30	2 2	Low Arc

High Sensitivity

Fuel	Size	Distance feet (m)	Horizontal (degrees)	Typical Response Time (seconds)	Vertical (degrees)	Typical Response (seconds)	Mode
n-Heptane	1 x 1 foot	30 (9.1)	+45 -45	1 1	+45 -30	1 1	Standard
n-Heptane	1 x 1 foot	30 (9.1)	+45 -45	1 1	+45 -30	1 1	Hi Arc
n-Heptane	1 x 1 foot	30 (9.1)	+45 -45	2 2	+45 -30	2 2	Very Hi Arc
Methane	32 inch plume	40 (12.2)	+45 -45	1 1	+45 -30	1 1	Standard
Methane	32 inch plume	40 (12.2)	+45 -45	1 1	+45 -30	1 1	Hi Arc
Methane	32 inch plume	35 (10.7)	+45 -45	1 1	+45 -30	1 1	Very Hi Arc

Medium Sensitivity

Fuel	Size	Distance feet (m)	Horizontal (degrees)	Typical Response Time (seconds)	Vertical (degrees)	Typical Response (seconds)	Mode
n-Heptane	1 x 1 foot	17.5 (5.3)	+45 -45	1 1	+45 -30	1 1	Standard
n-Heptane	1 x 1 foot	25 (7.6)	+45 -45	1 1	+45 -30	1 1	Hi Arc
Methane	32 inch plume	30 (9.1)	+45 -45	2 2	+45 -30	2 2	Standard
Methane	32 inch plume	30 (9.1)	+45 -45	1 1	+45 -30	1 1	Hi Arc

FM Approval and Performance Report – Continued

MODEL X2200M

The X2200M uses a sensor that has a broader spectrum than the standard sensor. It is designed to detect fires with unusual chemistry such as black powder. Consult factory for usage recommendations.

X2200M RESPONSE CHARACTERISTICS

High Sensitivity

Fuel	Size	Distance feet (m)	Typical Response Time (seconds)	Mode
Black Powder	40 grams	10 (3)	0.1	Standard

X2200M RESPONSE CHARACTERISTICS IN THE PRESENCE OF FALSE ALARMS

High Sensitivity (Standard Mode)

False Alarm Source	Distance feet (m)	Fire Source	Distance feet (m)	Typical Response Time (seconds)
Sunlight, direct, reflected, modulated & unmodulated	—	2-inch dia n-Heptane	10 (3)	<15
70 w sodium vapor lamp, modulated & unmodulated	3 (0.9)	1 x 1 foot n-Heptane	40 (12)	0.1
250 w vapor lamp, modulated & unmodulated	3 (0.9)	1 x 1 foot n-Heptane	40 (12)	0.1
300 w incandescent lamp, modulated & unmodulated	3 (0.9)	1 x 1 foot n-Heptane	40 (12)	0.1
500 w halogen lamp, modulated & unmodulated	3 (0.9)	1 x 1 foot n-Heptane	40 (12)	0.1
1500 w electric radiant heater, modulated & unmodulated	10 (3)	1 x 1 foot n-Heptane	40 (12)	0.1
2-34 w fluorescent lamps, modulated & unmodulated	3 (0.9)	1 x 1 foot n-Heptane	40 (12)	0.1

X2200M FALSE ALARM IMMUNITY

High Sensitivity (Standard Mode)

False Alarm Source	Distance feet (m)	Modulated Response	Unmodulated Response
Sunlight, direct, reflected	—	No Alarm	No Alarm
70 w sodium vapor lamp	3 (0.9)	No Alarm	No Alarm
250 w vapor lamp	3 (0.9)	No Alarm	No Alarm
300 w incandescent lamp	3 (0.9)	No Alarm	No Alarm
500 w halogen lamp	3 (0.9)	No Alarm	No Alarm
1500 w electric radiant heater	3 (0.9)	No Alarm	No Alarm
2-34 w fluorescent lamps	3 (0.9)	No Alarm	No Alarm

X2200M FIELD OF VIEW

High Sensitivity (Standard Mode)

Fuel	Size	Distance feet (m)	Horizontal (degrees)	Typical Response Time (seconds)	Vertical (degrees)	Typical Response (seconds)
Black Powder	40 grams	5 (1.5)	+45	0.1	+45	0.1
			-45	0.1	-30	0.1

APPENDIX B

CSA APPROVAL

DIVISION CLASSIFICATION:

Ultraviolet Flame Detector/Controller X2200 series, rated 18-30 Vdc, 2.5 Watts to 7.6 Watts.
Relay contacts rated 5 Amps @ 30 Vdc.

CLASS 4818 04 - SIGNAL APPLIANCES - Systems - For Hazardous Locations

Class I, Division 1, Groups B, C, and D (T5); Class II, Division 1, Groups E, F, and G (T5);
Class I, Division 2, Groups A, B, C, and D (T3); Class II, Division 2, Groups F and G (T3);
Class III; Enclosure NEMA/Type 4X;

APPLICABLE REQUIREMENTS

- CAN/CSA-C22.2 No. 0-M91 – General requirements - Canadian Electrical Code, Part II
- CAN/CSA-C22.2 No. 25-1966 – Enclosures for use in Class II Groups E,F, & G Hazardous Locations
- CAN/CSA-C22.2 No. 30-M1986 – Explosion-Proof Enclosures for Use in Class I Hazardous Locations
- CAN/CSA-C22.2 No. 94-M91 – Special Purpose Enclosures
- CAN/CSA-C22.2 No. 142-M1987 – Process Control Equipment
- CAN/CSA-C22.2 No. 213-M1987 – Nonincendive Electrical Equipment for Use in Class I, Division 2 Hazardous Locations

ZONE CLASSIFICATION:

CLASS 4818 04 - SIGNAL APPLIANCES - Systems - For Hazardous Locations

Ex db eb IIC T6...T5

T6 (Tamb = -50°C to +60°C)

T5 (Tamb = -50°C to +75°C)

Ex tb IIIC T95°C

(Tamb = -50°C to +75°C)

Seal required adjacent to enclosure

IP66/IP67

Ex db IIC T6...T5

T6 (Tamb = -55°C to +60°C)

T5 (Tamb = -55°C to +75°C)

Ex tb IIIC T95°C

(Tamb = -55°C to +75°C)

Seal required adjacent to enclosure

IP66/IP67

APPLICABLE REQUIREMENTS

- CAN/CSA-C22.2 No. 60079-0: 2007 – Electrical apparatus for explosive atmospheres. Part 0: General requirements
- CAN/CSA-C22.2 No. 60079-1: 2011 – Explosive atmospheres. Part 1: Equipment protection by flameproof enclosures "d"
- CAN/CSA-C22.2 No. 60079-7: 2012 – Explosive atmospheres. Part 7: Equipment protection by increased safety "e"
- CAN/CSA-C22.2 No. 60079-31: 2012 – Explosive atmospheres. Part 31: Equipment dust ignition protection by enclosure "t"

The following accessories are CSA approved for use with the X2200 Flame Detector:

Part Number	Description
102740-002	Magnet
007739-001	Magnet and Extension Pole
007290-001	Q9033B Stainless Steel Mounting Arm Assembly is for aluminum and stainless steel detectors
007290-002	Q9033A Aluminum Mounting Arm Assembly is for aluminum detectors only
011385-001	Q9033 Collar Attachment

APPENDIX C

ATEX APPROVAL

EC-TYPE EXAMINATION CERTIFICATE

DEMKO 02 ATEX 132195X

Increased Safety Model

CE 0539  II 2 G
II 2 D

Ex db eb IIC T6...T5

Ex tb IIIC T80°C

T6 (Tamb = -50°C to +60°C)

T5 (Tamb = -50°C to +75°C)

IP66/IP67.

Flameproof Model

CE 0539  II 2 G
II 2 D

Ex db IIC T6...T5

Ex tb IIIC T80°C

T6 (Tamb = -55°C to +60°C)

T5 (Tamb = -55°C to +75°C)

IP66/IP67.

Compliance with:

EN 60079-0: 2012+A11:2013

EN 60079-1: 2014

EN 60079-7: 2007

EN 60079-31: 2009

EN 60529:1991+A1:2000+A2:2013

INSTALLATION INSTRUCTIONS

The field wiring connections in the terminal compartment are ATEX certified and accepts wiring specifications from 14-24 AWG or 2.5-0.2 mm².

The flame detector model X2200UV shall be installed according to the instructions given by the manufacturer.

The cable entry devices shall be certified in type of explosion protection flameproof enclosure "d" for use with the terminal compartment in type of explosion protection flameproof enclosure "d," or in type of explosion protection increased safety "e" for use with the terminal compartment in type of explosion protection increased safety "e." They shall be IP66/IP67 rated, suitable for the conditions of use, and correctly installed.

Unused entries shall be closed with suitable certified blanking elements.

The metal housing for the Ultraviolet (UV) flame detector type X2200 must be electrically connected to earth ground.

For ambient temperatures below -10°C and above +60°C use field wiring suitable for both minimum and maximum ambient temperature.

Special conditions for safe use:

- The EOL resistor can only be used within the flameproof terminal compartment.
- EOL resistors must be ceramic, wirewound type, rated 5 watts minimum, with actual power dissipation not to exceed 2.5 watts.
- The Ultraviolet (UV) flame detector type X2200 is to be installed in places where there is a low risk of mechanical damage.
- See the "Maintenance" section of this manual for guidance on minimizing risk from electrostatic discharge.
- Flameproof joints are not intended to be repaired. See the "Device Repair and Return" section of this manual for more information on conducting repairs.

NOTE

Operational performance verified from -40°C to +75°C.

NOTE

An optional third party addressable module can only be used within the Ex d flameproof model unless the addressable module is component certified as Ex e for use within the Ex d e increased safety model.

NOTE

Refer to "EOL Resistors" section for installation details. All cable entry devices and blanking elements shall be certified to "E-generation" or "ATEX" standards, in type of explosion protection increased safety "e" or flameproof enclosure "d" (as applicable), suitable for the conditions of use and correctly installed. They shall maintain the degree of ingress protection IP66/IP67 for the apparatus. Unused conduit entries shall be closed with suitable blanking elements.

NOTE

For ATEX installations, the X2200 Flame Detector housing must be electrically connected to earth ground.

The following accessories are ATEX approved for use with the X2200 Flame Detector:

Part Number	Description
007290-001	Q9033B Stainless Steel Mounting Arm Assembly is for aluminum and stainless steel detectors
007290-002	Q9033A Aluminum Mounting Arm Assembly is for aluminum detectors only
011385-001	Q9033 Collar Attachment

APPENDIX D

IECEX APPROVAL

CERTIFICATE OF CONFORMITY

IECEX ULD 06.0018X

Ex db eb IIC T6...T5		Ex db IIC T6...T5
Ex tb IIIC T80°C		Ex tb IIIC T80°C
T6 (Tamb = -50°C to +60°C)	or	T6 (Tamb = -55°C to +60°C)
T5 (Tamb = -50°C to +75°C)		T5 (Tamb = -55°C to +75°C)
IP66/IP67.		IP66/IP67.

Compliance with:

IEC 60079-0: 2011, Ed. 6
 IEC 60079-1: 2014, Ed. 7
 IEC 60079-7: 2006, Ed. 4
 IEC 60079-31: 2008, Ed. 1
 IEC 60529: 2013, Ed. 2.2

INSTALLATION INSTRUCTIONS

The field wiring connections in the terminal compartment are suitable certified and accepts wiring specifications from 14-24 AWG or 2.5-0.2 mm².

The flame detector model X2200UV shall be installed according to the instructions given by the manufacturer.

The cable entry devices shall be certified in type of explosion protection flameproof enclosure "d" for use with the terminal compartment in type of explosion protection flameproof enclosure "d", or in type of explosion protection increased safety "e" for use with the terminal compartment in type of explosion protection increased safety "e". They shall be IP66/IP67 rated, suitable for the conditions of use and correctly installed.

Unused entries shall be closed with suitable certified blanking elements.

The metal housing for the Ultraviolet (UV) flame detector type X2200 must be electrically connected to earth ground.

For ambient temperatures below -10°C and above +60°C use field wiring suitable for both minimum and maximum ambient temperature.

Special conditions for safe use:

- The EOL resistor can only be used within the flameproof terminal compartment.
- EOL resistors must be ceramic, wirewound type, rated 5 watts minimum, with actual power dissipation not to exceed 2.5 watts.
- The Ultraviolet (UV) flame detector type X2200 is to be installed in places where there is a low risk of mechanical damage.
- See the "Maintenance" section of this manual for guidance on minimizing risk from electrostatic discharge.
- Flameproof joints are not intended to be repaired. See the "Device Repair and Return" section of this manual for more information on conducting repairs.

The following accessories are IECEx approved for use with the X2200 Flame Detector:

Part Number	Description
007290-001	Q9033B Stainless Steel Mounting Arm Assembly is for aluminum and stainless steel detectors
007290-002	Q9033A Aluminum Mounting Arm Assembly is for aluminum detectors only
011385-001	Q9033 Collar Attachment



95-8552



FlexSonic® Acoustic
Leak Detector



X3301 Multispectrum
IR Flame Detector



PointWatch Eclipse® IR
Combustible Gas Detector



FlexVu® Universal Display
with GT3000 Toxic Gas Detector



Eagle Quantum Premier®
Safety System

Specifications subject to change without notice.

All trademarks are the property of their respective owners.
© 2020 Detector Electronics Corporation. All rights reserved.

Det-Tronics manufacturing system is certified to ISO 9001—
the world's most recognized quality management standard.



Corporate Office
6901 West 110th Street
Minneapolis, MN 55438 USA
www.det-tronics.com

Phone: +1 952.941.6665
Toll-free: +1 800.765.3473
Fax: 952.829.8750
det-tronics@carrier.com