

Instructions

UVIR Flame Detector Series
X5200, X5200G, and X5200M



Table of Contents

| | | | |
|--|----|---|----|
| DESCRIPTION | 1 | TROUBLESHOOTING | 15 |
| Outputs | 1 | | |
| LED | 2 | MAINTENANCE | 16 |
| oi (Optical Integrity) | 2 | Cleaning Procedure | 16 |
| Communication | 3 | oi Reflector Plate Removal and Replacement | 16 |
| Data Logging | 3 | Periodic Checkout Procedure | 17 |
| Integral Wiring Compartment | 3 | Clock Battery | 17 |
| SIGNAL PROCESSING OPTIONS | 3 | FEATURES | 17 |
| IR Detector Options | 3 | | |
| UV Detector Options | 4 | SPECIFICATIONS | 18 |
| GENERAL APPLICATION INFORMATION | 4 | REPLACEMENT PARTS | 20 |
| Response Characteristics | 4 | Replacement Parts List | 20 |
| False Alarm Sources | 5 | DEVICE REPAIR AND RETURN | 20 |
| Factors Inhibiting Detector Response | 5 | | |
| IMPORTANT SAFETY NOTES | 6 | ORDERING INFORMATION | 20 |
| INSTALLATION | 7 | Accessories | 20 |
| Detector Positioning | 7 | X5200 Series Model Matrix | 21 |
| Detector Orientation | 7 | APPENDIX A – FM APPROVAL AND | |
| Protection Against Moisture Damage | 8 | PERFORMANCE REPORT | 22 |
| Wiring Procedure | 8 | | |
| Setting Device Network Addresses | | APPENDIX B – CSA APPROVAL | 27 |
| (EQ and EQP Models Only) | 14 | | |
| STARTUP PROCEDURE | 15 | APPENDIX C – ATEX APPROVAL | 28 |
| Fire Alarm Test | 15 | APPENDIX D – IECEx APPROVAL | 29 |
| | | APPENDIX E – EN54 APPROVALS | 30 |
| | | APPENDIX F – ADDITIONAL APPROVALS | 31 |
| | | APPENDIX G – DECLARATION OF | |
| | | CONFORMITY | 32 |

AUTOMATIC

**UVIR Flame Detector Series
X5200, X5200G, and X5200M****IMPORTANT**

Be sure to read and understand the entire instruction manual before installing or operating the flame detection system. Any deviation from the recommendations in this manual may impair system performance and compromise safety.

ATTENTION

The X5200, X5200G, and X5200M include the Automatic **oi**[®] (Optical Integrity) feature — a calibrated performance test that is automatically performed once per minute to verify complete detector operation capabilities. **Testing with an external test lamp is not approved or required.**

**DESCRIPTION**

The X5200, X5200G, and X5200M UV Flame Detectors meet the most stringent requirements worldwide with advanced detection capabilities and immunity to extraneous sources, combined with a superior mechanical design. The mounting arrangement allows the UV and IR sensors to monitor the same hazardous location with a 90 degree cone of vision. When both sensors simultaneously detect the presence of a flame, an alarm signal is generated. The detectors have Division and Zone explosion-proof ratings and is suitable for use in indoor and outdoor applications.

The standard output configuration includes fire, fault and auxiliary relays. Output options include:

- 0 to 20 mA output (in addition to the three relays)
- Pulse output for compatibility with existing Detector Electronics Corporation (Det-Tronics) controller based systems (with fire and fault relays)
- Eagle Quantum Premier[®] (EQP) compatible model (no analog or relay outputs)
- HART communication

A tri-color LED on the detector faceplate indicates normal condition and notifies personnel of fire alarm or fault conditions.

Microprocessor controlled heated optics increase resistance to moisture and ice.

The detector housing is available in copper-free aluminum or stainless steel, with Type 4X and IP66/IP67 rating.

OUTPUTS**Relays**

The standard detector is furnished with fire, fault, and auxiliary relays. All three relays are rated 5 amperes at 30 Vdc.

The Fire Alarm relay has redundant terminals and normally open / normally closed contacts, normally de-energized operation, and latching or non-latching operation.

The Fault relay has redundant terminals and normally open contacts, normally energized operation, and latching or non-latching operation.

The Auxiliary relay has normally open / normally closed contacts, and is configurable for energized or de-energized operation, and latching or non-latching operation.

0 to 20 mA Output

A 0 to 20 mA output is available as an option (in addition to the three relays). This option provides a 0–20 mA dc current output for transmitting detector status information to other devices. The circuit can be wired in either an isolated or non-isolated configuration and can drive a maximum loop resistance of 500 ohms from 18 to 19.9 Vdc and 600 ohms from 20 to 30 Vdc. Table 1 indicates the detector status conditions represented by the various current levels. The output is calibrated at the factory, with no need for field calibration. A model with relays and 0–20 mA with HART is also available. Refer to Addendum number 95-8636 for complete details.

NOTE

The output of the 0–20 mA current loop is not monitored by the fault detection circuitry of the detector. Therefore, an open circuit on the loop will not cause the fault relay to change state or the detector status LED to indicate a fault. The status of the LED always follows the status of the relays.

An alarm condition will normally over-ride a fault condition, unless the nature of the fault condition impairs the ability of the detector to generate or maintain an alarm output, i.e., loss of operating power.

Table 1—Detector Status Conditions Indicated by Current Level

| Current Level (±0.3 mA) | Detector Status |
|-------------------------|-------------------|
| 0 mA | Power Fault |
| 1 mA | General Fault |
| 2 mA | oi Fault |
| 4 mA | Normal Operation |
| 8 mA | IR Pre-Alarm only |
| 12 mA | UV Alarm only |
| 14 mA | IR Alarm only |
| 16 mA | Pre-Alarm |
| 20 mA | Fire Alarm |

LON/SLC Output

The EQP model is designed for use exclusively with the Det-Tronics Eagle Quantum Premier system. The detector communicates with the system controller over a digital communication network or LON/SLC (Local Operating Network / Signaling Line Circuit). The LON/SLC is a fault tolerant, two wire digital communication network arranged in a loop configuration. Analog and relay outputs are not available on this model.

LED

A tri-color LED on the detector faceplate indicates normal condition and notifies personnel of fire alarm or fault conditions. Table 2 indicates the condition of the LED for each status.

Table 2—Detector Status Indicator

| Detector Status | LED Indicator |
|--|--|
| Power On/Normal Auto oi (no fault or fire alarm) | Green |
| Power On/Normal Man oi | Green, flashing off for 0.5 sec. every 5 sec. |
| Fault | Yellow |
| UV Alarm only | Red, flashing on for 0.5 sec. and off for 0.5 sec. |
| IR Alarm only | Red, flashing on for 0.25 sec. and off for 0.25 sec. |
| Pre-Alarm | Red, flashing on for 1 sec. and off for 1 sec. |
| Fire (Alarm) | Steady Red |
| On Power-Up, The LED Flashes in Sequence as Follows, Indicating Sensitivity and Signal Processing Status | |
| Low UV Sensitivity | One Red Flash |
| Medium UV Sensitivity | Two Red Flashes |
| High UV Sensitivity | Three Red Flashes |
| Very High UV Sensitivity | Four Red Flashes |
| Stand. UV Signal Process. | One Yellow Flash |
| Arc Rej. UV Signal Process. | Two Yellow Flashes |
| Low IR Sensitivity | One Green Flash |
| Medium IR Sensitivity | Two Green Flashes |
| High IR Sensitivity | Three Green Flashes |
| Very High IR Sensitivity | Four Green Flashes |
| Quick Fire/TDSA IR Signal | One Yellow Flash |
| TDSA only IR Signal | Two Yellow Flashes |

ATTENTION

*The X5200 and X5200M contain a source tube that is filled with a gas mixture containing Krypton 85 (Kr⁸⁵), a radioactive material. Radioactive materials are subject to regulation under U.S. and international law. **Not applicable to model X5200G, which does not contain Kr⁸⁵.***

oi (OPTICAL INTEGRITY)

Automatic oi

The X5200, X5200G, and X5200M include the Automatic **oi** feature — a calibrated performance test that is automatically performed once per minute to verify complete detector operation capabilities. No testing with an external test lamp is required. The detector automatically performs the same test that a maintenance person with a test lamp would perform — once every minute, 60 times per hour. However, a successful Automatic **oi** test does not produce an alarm condition.

The detector signals a fault condition when less than half of the detection range remains. This is indicated by the Fault output and is evident by the yellow color of the LED on the face of the detector. See the "Troubleshooting" section for further information.

Magnetic **oi** / Manual **oi**

The detector also incorporates both Magnetic **oi** (Mag **oi**) and Manual **oi** (Man **oi**) features that provide the same calibrated test as the Automatic **oi**, and in addition actuates the Alarm output to verify operation for preventive maintenance requirements. These features can be performed at any time and eliminate the need for testing with a non-calibrated external test lamp.

CAUTION

These tests require disabling of all extinguishing devices to avoid release resulting from a successful test.

The Mag **oi** test is performed by placing a magnet at the location marked "MAG OI" on the outside of the detector (see Figure 2). The Man **oi** test is accomplished by connecting the **oi** lead (terminal 22) to power supply minus via an external switch. The magnet or switch must be held in place for a minimum of 6 seconds to complete the test. Either of these test methods activates the calibrated UV and IR emitters. If the resulting signal meets the test criteria, indicating that greater than half of the detection range remains, the fire alarm output of the detector is activated. On models with relay, 0–20 mA, or HART outputs, this condition remains until the magnet is removed or the switch is released, regardless of whether the detector has been configured for latching or non-latching operation. The fire alarm output condition stays active for three seconds on Eagle Quantum Premier models.

If less than half of the detection range remains, no alarm is produced and a fault is generated. The fault indication can be reset by momentarily applying the Mag **oi** or Man **oi** switch. In this case, the detector's optics should be cleaned and the **oi** tests should be repeated. See the "Cleaning Procedure" section of this manual for details.

NOTE

*Refer to Appendix A for FM verification of the **oi** function.*

COMMUNICATION

The detector is furnished with an RS-485 interface for communicating status and other information with external devices. The RS-485 supports Modbus protocol, with the detector configured as a slave device.

For HART communication, connect a HART communicator across a 250 ohm resistor in the 0–20 mA loop. HART output models do not support RS-485 Modbus protocol.

NOTE

The EQP model uses LON/SLC communication. RS-485 and HART communication are not available on the EQP model.

NOTE

RS-485 communication is not available on HART equipped models.

DATA LOGGING

Data logging capability is also provided. Status conditions such as normal, power down, general and **oi** faults, pre-alarm, fire alarm, time and temperature are recorded. Each event is time and date stamped, along with the temperature and input voltage. Event data is stored in non-volatile memory when the event becomes active and again when the status changes. Data is accessible using the Inspector Connector accessory, RS-485, or the EQP Controller.

INTEGRAL WIRING COMPARTMENT

All external wiring to the device is connected within the terminal compartment. The detector is furnished with four conduit entries, with either 3/4 inch NPT or M25 threads.

SIGNAL PROCESSING OPTIONS

The X5200, X5200G, and X5200M feature signal processing options for both the UV and IR sensor. These options determine the type of logic that the detector will use for processing fire signals to customize the detector to the application.

IR DETECTOR OPTIONS

The IR detector in the X5200, X5200G, and X5200M can be programmed for:

- TDSA enabled
- Both TDSA and Quick Fire enabled (either initiates fire alarm)

Time Domain Signal Analysis (TDSA)

The TDSA signal processing technique analyzes the input signal in real time, requiring the IR signal to flicker randomly in order to recognize it as a fire condition.

Using TDSA signal processing, the detector ignores regularly chopped blackbody sources (occurring in areas where moving conveyors and hot objects in proximity to one another result in a regularly chopped IR signal), because it looks for a less uniform signal. However, in the presence of a regularly chopped signal, the detector may be more susceptible to false alarms due to sporadic IR that functions as a trigger when occurring in conjunction with the regularly chopped signal.

Quick Fire (High Speed)

The Quick Fire (High Speed) feature can be used in conjunction with the TDSA signal processing method. This method overrides TDSA requirements in the event of a sudden and intense signal, such as the result of a flash fire. When Quick Fire is activated, the detector is capable of responding to an intense fire signal in less than 30 milliseconds (0.030 seconds). Using the Quick Fire feature in conjunction with TDSA signal processing allows the detector to provide a high speed response to a large, non-flickering fire (such as in high pressure gas applications). Additionally, when the Quick Fire feature and TDSA signal processing are used in conjunction, the detector maintains an ability to respond to fires that start very small and grow in size and intensity over time.

UV DETECTOR OPTIONS

The UV detector output (measured in counts per second) is compared to the fire threshold (the “sensitivity” setting). If the radiant energy level from the fire exceeds the selected alarm threshold level, the UV fire alarm output is activated. In every application, it is crucial to ensure that the radiant ultraviolet energy level from the expected fire at the required distance from the detector will exceed the selected sensitivity level.

The UV detector in the X5200, X5200G, and X5200M can be programmed for:

- Arc Rejection
- Standard Signal Processing

Arc Rejection

The Arc Rejection mode enables the detector to prevent nuisance fire alarms caused by UV from short-duration electrical arcs or electrostatic discharge, while maintaining the ability to reliably detect the UV radiation given off by a flame. Typical applications that benefit from arc rejection logic include uncontrolled environments where transient UV sources can be present, such as many typical outdoor applications. Most false alarm sources have short transient UV signatures, while fire creates a long UV signature over many seconds. Most fires are detected in a few seconds (see response times in Appendix A).

Standard Signal Processing

Standard signal processing is recommended for high-speed suppression systems only. To allow for high-speed operation, the standard processing mode does not incorporate the arc rejection programming. This mode should only be used in a controlled, indoor environment or in applications where the need for high speed detection outweighs the need for resistance against unwarranted UV alarms.

GENERAL APPLICATION INFORMATION

RESPONSE CHARACTERISTICS

Response is dependent on the detector's sensitivity setting, arc rejection, and time delay settings. Other factors include distance, type of fuel, temperature of the fuel, and time required for the fire to come to equilibrium. As with all fire tests, results must be interpreted according to an individual application.

See Appendix A for third-party approved fire test results. Additional fire test results are available from Det-Tronics.

Welding

Electric arc welding is a source of intense ultraviolet radiation. UV radiation from arc welding readily scatters and can deflect across significant distances, even when direct obstructions exist. Any open door or window can allow nuisance UV radiation from arc welding to enter an enclosed area, causing a possible response from the UV detector.

It is recommended that the system be inhibited during welding operations in situations where the possibility of a false alarm cannot be tolerated. Gas welding mandates system inhibit, since the gas torch is an actual fire. Arc welding rods can contain organic binder materials in the flux that burn during the welding operation and are detectable by the detector. Welding rods with clay binders do not burn and will not be detected by the detector. However, system inhibit is always recommended, since the material being welded may be contaminated with organic substances (paint, oil, etc.) that will burn and possibly cause the detector to alarm.

Artificial Lighting

The detector should not be located within 3 feet (0.9 m) of artificial lights. Excess heating of the detector could occur due to heat radiating from the lights.

EMI/RFI Interference

The detector is resistant to interference by EMI and RFI, and is EMC Directive compliant and CE marked. It will not respond to a 5 watt walkie-talkie at distances greater than 1 foot (0.3 m).

Non-Carbon Fires

The UV/IR Fire Alarm response of the detector is limited to carbonaceous fuels. It should not be used to detect fires from fuels that do not contain carbon, such as hydrogen, sulfur, and burning metals. The Auxiliary relay can be configured to change states upon a UV alarm only. When configured in this manner, the UV sensor within the detector can be used to detect non-carbonaceous fires.

FALSE ALARM SOURCES

UV: The UV sensor is solar blind to the ultraviolet component of solar radiation. However, it may respond to sources of UV besides fire, such as arc flash, electric arc welding, grinding metal, lightning, high voltage corona, x-rays, and gamma radiation.

NOTE

Radiation generated by false alarm sources such as periodic lightning or sparks in the area may be effectively ignored by the detector using the arc rejection feature or time delay.

IR: The detector has been designed to ignore steady state infrared sources that do not have a flicker frequency characteristic of a fire, however, it should be noted that if these steady state infrared sources are hot enough to emit adequate amounts of infrared radiation in the response range of the IR sensor and if this radiation becomes interrupted from the view of the detector in a pattern characteristic of a flickering flame, the IR sensor can respond.

Any object having a temperature greater than 0° Kelvin (-273°C) emits infrared radiation. The hotter the object, the greater the intensity of the emitted radiation. The closer the infrared source is to the detector, the greater the potential for a false alarm. The IR sensor can respond to IR radiation sources that can meet the amplitude and flicker requirements of the detector such as vibrating hot objects.

Although the detector is designed to reduce false actuations, certain combinations of ambient radiation must be avoided. For example, if IR radiation with an intensity that exceeds the fire threshold of the IR sensor should reach the detector as a flickering signal, and if at the same time an electric arc welding signal also reaches the detector, an alarm output will be generated.

FACTORS INHIBITING DETECTOR RESPONSE

Windows

Glass and Plexiglas windows significantly attenuate radiation and must not be located between the detector and a potential flame source. If the window cannot be eliminated or the detector location changed, contact Det-Tronics for recommendations regarding window materials that will not attenuate radiation.

Obstructions

Radiation must be able to reach the detector in order for it to respond. Care must be taken to keep physical obstructions out of the line of view of the detector. In addition, UV or IR absorbing gases or vapors must not be allowed to accumulate between the detector and the protected hazard. See Table 3 for a list of these substances.

Smoke

Smoke will absorb radiation. If accumulations of dense smoke can be expected to precede the presence of a flame, then detectors that are used in enclosed areas should be mounted on the wall approximately 3 feet (0.9 m) from the ceiling where the accumulation of smoke is reduced.

Detector Viewing Windows

It is important to keep the detector viewing windows as free of contaminants as possible in order to maintain maximum sensitivity. Commonly encountered substances that can significantly attenuate UV and/or IR radiation include, but are certainly not limited to, the following:

- Silicones
- Oils and greases
- Dust and dirt buildup
- Paint overspray
- Water and ice

Table 3—UV and IR Absorbing Gases and Vapors

The following is a partial list of compounds that exhibit significant UV absorption characteristics. These are also usually hazardous vapors. While generally of little consequence in small amounts, these gases can restrict UV detection if they are in the atmosphere in heavy concentrations. It should also be determined whether or not large amounts of these gases may be released as a result of a fire-causing occurrence.

| | |
|-------------------------|---------------------|
| Acetaldehyde | Methyl Methacrylate |
| Acetone | Alpha-Methylstyrene |
| Acrylonitrile | Naphthalene |
| Ethyl Acrylate | Nitroethane |
| Methyl Acrylate | Nitrobenzene |
| Ethanol | Nitromethane |
| Ammonia | 1-Nitropropane |
| Aniline | 2-Nitropropane |
| Benzene | 2-Pentanone |
| 1,3 Butadiene | Phenol |
| 2-Butanone | Pyridine |
| Butylamine | Hydrogen Sulfide |
| Chlorobenzene | Styrene |
| 1-Chloro-1-Nitropropane | Tetrachloroethylene |
| Chloroprene | Toluene |
| Cumene | Trichloroethylene |
| Cyclopentadiene | Vinyl Toluene |
| O-Dichlorobenzene | Xylene |
| P-Dichlorobenzene | |

If UV-absorbing gases may be a factor in a given application, precautionary measures should be taken. Detectors can be placed closer to the potential hazard area, and/or the sensitivity of the detection system can be increased. Contact the factory for further details.

Substances such as methane, propane, butane, hexane, camphor, and octane are not UV absorbing.

Absorption of infrared radiation in the range of 4.2 to 4.7 microns is not a significant problem with most organic vapors, with the exception of those compounds that have triple bonds such as acetylene, nitriles, silane, or isocyanates. Carbon dioxide concentrations higher than normally present in the atmosphere can also cause substantial loss of fire detection sensitivity.

IMPORTANT SAFETY NOTES

WARNING

Do not open the detector assembly in a hazardous area when power is applied. The detector contains limited serviceable components and should never be opened. Doing so could disturb critical optical alignment and calibration parameters, possibly causing serious damage.

CAUTION

The wiring procedures in this manual are intended to ensure proper functioning of the device under normal conditions. However, because of the many variations in wiring codes and regulations, total compliance to these ordinances cannot be guaranteed. Be certain that all wiring complies with the NEC as well as all local ordinances. If in doubt, consult the authority having jurisdiction before wiring the system. Installation must be done by a properly trained person.

CAUTION

To prevent unwanted actuation or alarm, extinguishing devices must be disabled prior to performing detection system tests or maintenance.

CAUTION

The UVIR flame detectors are to be installed in places where the risk of mechanical damage is low.

ATTENTION

Remove the protective cover from the front of the detector before activating the system.

ATTENTION

Observe precautions for handling electrostatic sensitive devices.

ATTENTION

*The source tube is a flame-sealed gas tube containing Neon, Hydrogen, and a trace amount of Krypton 85 (Kr⁸⁵), a radioactive material. The total volume of gas within the tube is 0.6 ml per tube, making the gas mixture inside the tube nonflammable. If the gas envelope is broken, it will not produce a flammable mixture, and the gas immediately disperses into the air and is unlikely to present any type of hazard. Krypton gas and its radioactive isotope are inert and are not absorbed by the body. No special handling measure or personal protection equipment is needed for the UVIR detectors. **Not applicable to model X5200G, which does not contain Kr⁸⁵.***

INSTALLATION

NOTE

The recommended lubricant for threads and O-rings is a silicone-free grease (p/n 005003-001) available from Detector Electronics. Under no circumstances should a lubricant containing silicone be used.

DETECTOR POSITIONING

Detectors should be positioned to provide the best unobstructed view of the area to be protected. The following factors should also be taken into consideration:

- Identify all high risk fire ignition sources.
- Be sure that enough detectors are used to adequately cover the hazardous area.
- Be sure that the unit is easily accessible for cleaning and other periodic servicing.
- Verify that all detectors in the system are properly located and positioned so that any fire hazards are within both the Field of View (FOV) and detection range of the detector. The Q1201C Laser Aimer is recommended for establishing the detector's FOV. Refer to Appendix A for specific information regarding detector range and FOV.
- The detector should be aimed downward at least 10 to 20 degrees to allow lens openings to drain (see Figure 1). **The detector should be positioned so that its FOV does not cover areas outside the area that requires flame detection monitoring.** This will minimize the possibility of false alarms caused by activities outside the area requiring protection.
- The detector must be mounted on a rigid surface in a low vibration area.

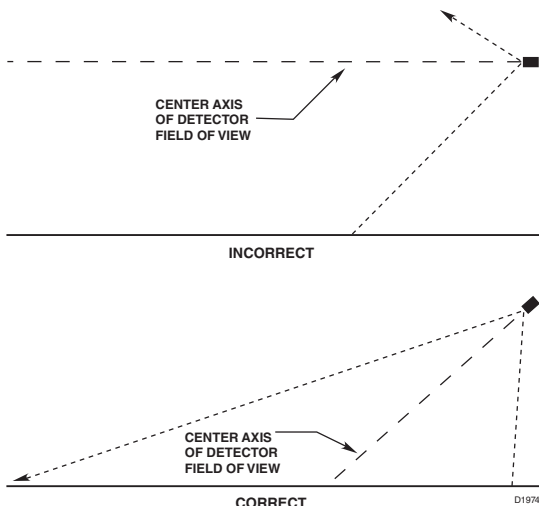

NOTE: DETECTOR MUST ALWAYS BE AIMED DOWNWARD AT LEAST 10 TO 20 DEGREES.

Figure 1—Detector Orientation Relative to Horizon

- Dense fog, rain as well as certain gases and vapors (see Table 3) can absorb UV and IR radiation and reduce the sensitivity of the detector.
- If possible, fire tests can be conducted to verify correct detector positioning and coverage.
- For ATEX/IECEx installations, the detector housing must be electrically connected to earth ground.

DETECTOR ORIENTATION

Refer to Figure 2 and ensure that the **oi** reflector plate will be oriented as shown when the detector is installed and sighted. This will ensure proper operation of the **oi** system and will also minimize the accumulation of moisture and contaminants between the **oi** reflector plate and the viewing windows.

IMPORTANT

If removed, the **oi** reflector plate **must** be securely tightened to ensure proper operation of the **oi** system (40 oz.inches [28.2 N·cm] recommended).

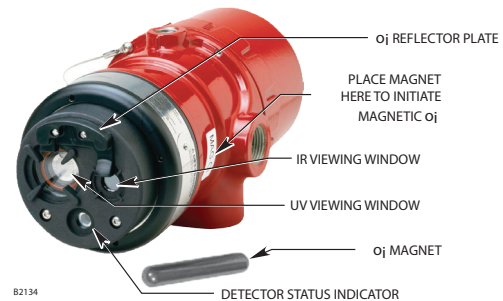

Figure 2—Front View of the Detector

PROTECTION AGAINST MOISTURE DAMAGE

It is important to take proper precautions during installation to ensure that moisture will not come in contact with the electrical connections or components of the system. The integrity of the system regarding moisture protection must be maintained for proper operation and is the responsibility of the installer. Verify all covers are securely tightened upon installation.

If conduit is used, we recommend installing drains, according to local codes, at water collection points to automatically drain accumulated moisture. It is also recommended to install at least one breather, according to local codes, at upper locations to provide ventilation and allow water vapor to escape.

Conduit raceways should be inclined so that water will flow to low points for drainage and will not collect inside enclosures or on conduit seals. If this is not possible, install conduit drains above the seals to prevent the collection of water or install a drain loop below the detector with a conduit drain at the lowest point of the loop.

Conduit seals are not required for compliance with explosion-proof installation requirements, but are highly recommended to prevent water ingress in outdoor applications. Units with M25 threads must use an IP66/IP67 washer to prevent water ingress.

WIRING PROCEDURE

Wire Size and Type

The system should be wired according to local codes. The wire size selected should be based on the number of detectors connected, the supply voltage and the cable length. Typically 16 AWG or 2.5 mm² shielded cable is recommended. Wires should be stripped 1/2 inch, 12 mm. A minimum input voltage of 18 Vdc must be present at the detector.

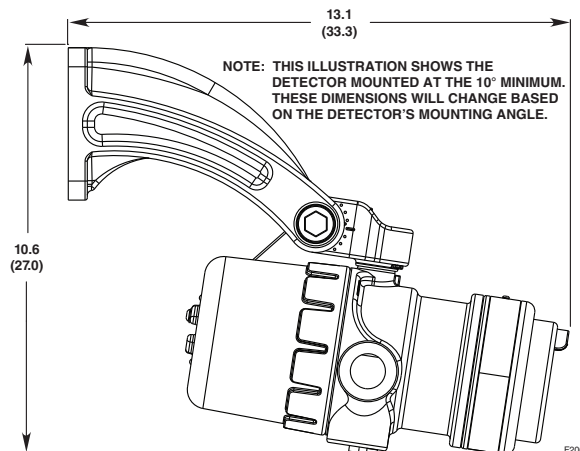
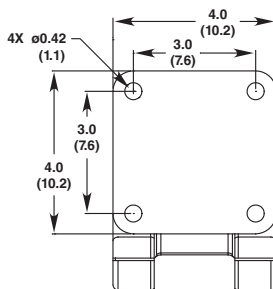

Figure 3—Q9033 Mounting Arm without Collar Attachment Dimensions in Inches (cm)
(See Figure 1 for Correct Detector Orientation.)

NOTE

Refer to “Power Consumption” in the “Specifications” section of this manual.

The use of shielded cable is required to protect against interference caused by EMI and RFI. When using cables with shields, terminate the shields as shown in Figures 7 through 13 and Figure 16. Consult the factory if not using shielded cable.

In applications where the wiring cable is installed in conduit, the conduit must not be used for wiring to other electrical equipment.

If disconnection of power is required, separate disconnect capability must be provided.

⚠ WARNING

All entries must contain appropriately rated plugs or fittings. It is required that each plug or fitting be wrench-tightened to an appropriate installation torque and meet the minimum thread engagement requirements per the applicable local standards, codes, and practices in order to retain the defined ratings. PTFE sealant or equivalent should be used on NPT threads.

IMPORTANT

Devices certified for hazardous locations shall be installed in accordance with EN/IEC 60079-14 and NEC 505.

⚠ CAUTION

Installation of the detector and wiring should be performed only by qualified personnel.

Detector Installation

Install the mounting arm assembly on a rigid surface. The ideal installation surface should be free of vibration and suitable to receive 3/8 inch or M10 bolts with a length of at least 1 inch (25 mm). The surface must also have sufficient capacity to hold the detector and mounting arm weights (See "Specifications" section). Refer to the Q9033 Mounting Arm manual, number 95-8686, for additional installation information. See Figure 3 for dimensions.

Relay and 0–20 mA Output Models

Follow the instructions below to install the X5200, X5200G, and X5200M.

1. Make field connections following local ordinances and guidelines in this manual. Refer to Figures 4 through 13.
2. Check all field wiring to be sure that the proper connections have been made.

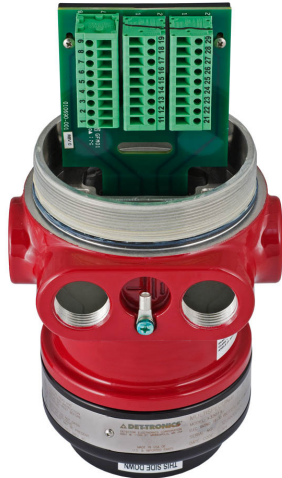

Figure 4—Detector Terminal Block

| | | | | | |
|---|-----------|----|-----------|----|--------------------|
| 9 | mA + | 19 | mA – | 29 | SPARE |
| 8 | mA + REF | 18 | mA – REF | 28 | SPARE |
| 7 | COM FIRE | 17 | COM FIRE | 27 | COM AUX |
| 6 | NO FIRE | 16 | NO FIRE | 26 | NO AUX |
| 5 | NC FIRE | 15 | NC FIRE | 25 | NC AUX |
| 4 | COM FAULT | 14 | COM FAULT | 24 | RS485 A |
| 3 | NO FAULT | 13 | NO FAULT | 23 | RS485 B |
| 2 | +Vin | 12 | +Vin | 22 | MAN O ₁ |
| 1 | -Vin | 11 | -Vin | 21 | -Vin |

E2061

Figure 5—Wiring Terminal Identification

3. Replace and securely tighten all covers before applying input power.

IMPORTANT

Do not test any wiring connected to the detector with a meg-ohmmeter. Disconnect wiring at the detector before checking system wiring for continuity.

4. Make the final sighting adjustments and use a 14 mm hex wrench to ensure that the mounting arm assembly is tight.

EOL, Fire and Fault Resistors (Not Used with EQP Model)

To ensure that the insulating material of the wiring terminal block will not be affected by the heat generated by the resistors, observe the following guidelines when installing the resistors.

1. Resistors must be rated appropriately for the application and have a maximum power dissipation of 5 watts.

NOTE

This applies to ATEX/IECEx installations only.

2. Resistor leads should be cut to a length of approximately 1 1/2 inches, 40 mm.
3. Bend the leads and install the resistors as shown in Figure 6.
4. Maintain a 3/8 inch, 10 mm minimum gap between the resistor body and the terminal block or any other neighboring parts.

NOTE

The resistors can only be used within the flameproof (Ex d) terminal compartment. Unused conduit entries shall be closed with suitable blanking elements.

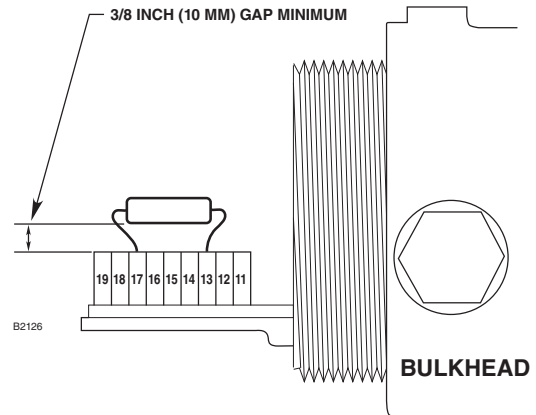

Figure 6—Resistor Installation (For Ex d Wiring Only)

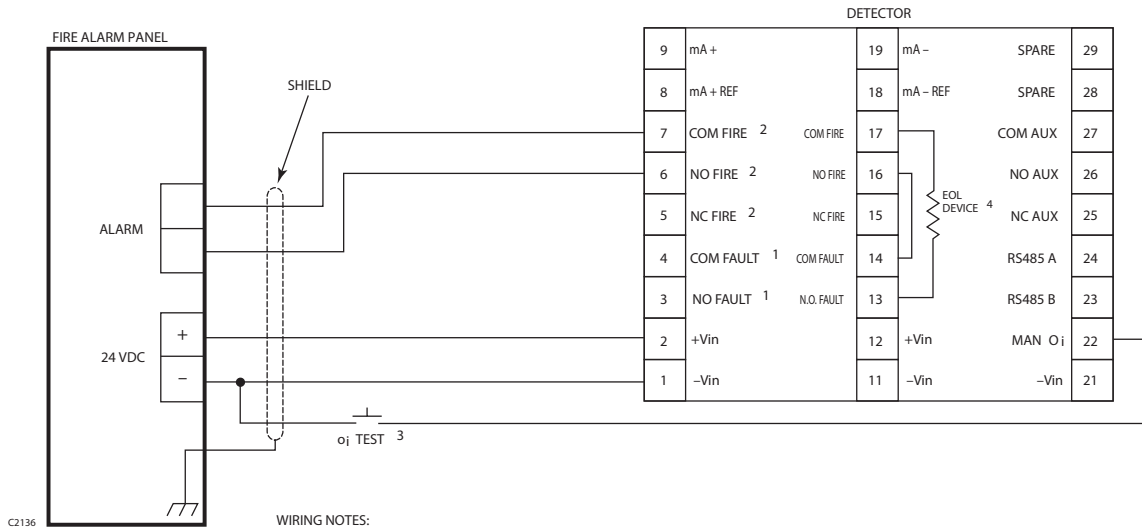

Figure 7—Ex d Wiring Option

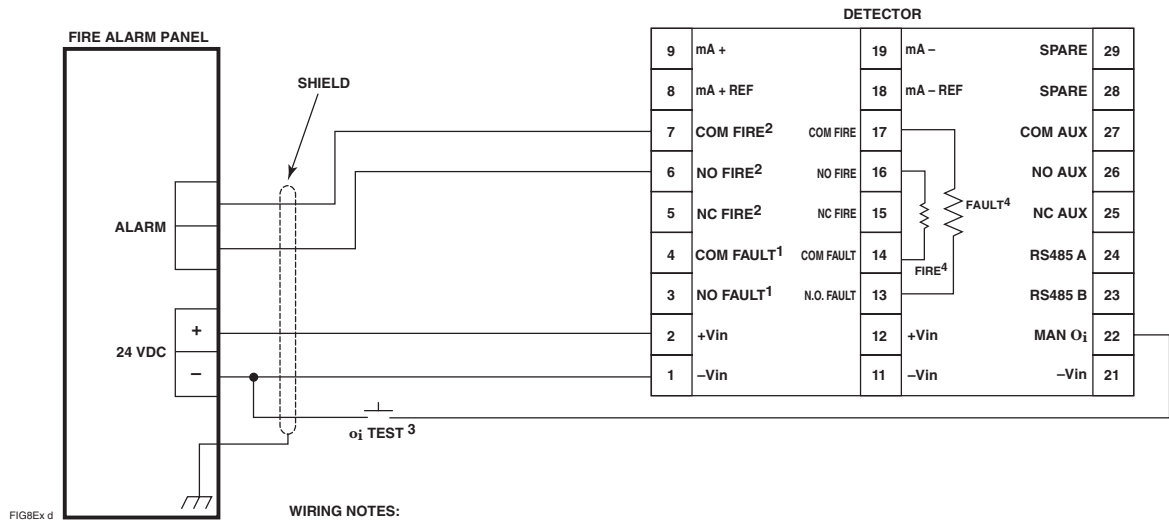

Figure 8—Ex d Wiring Option with Fire and Fault Resistors

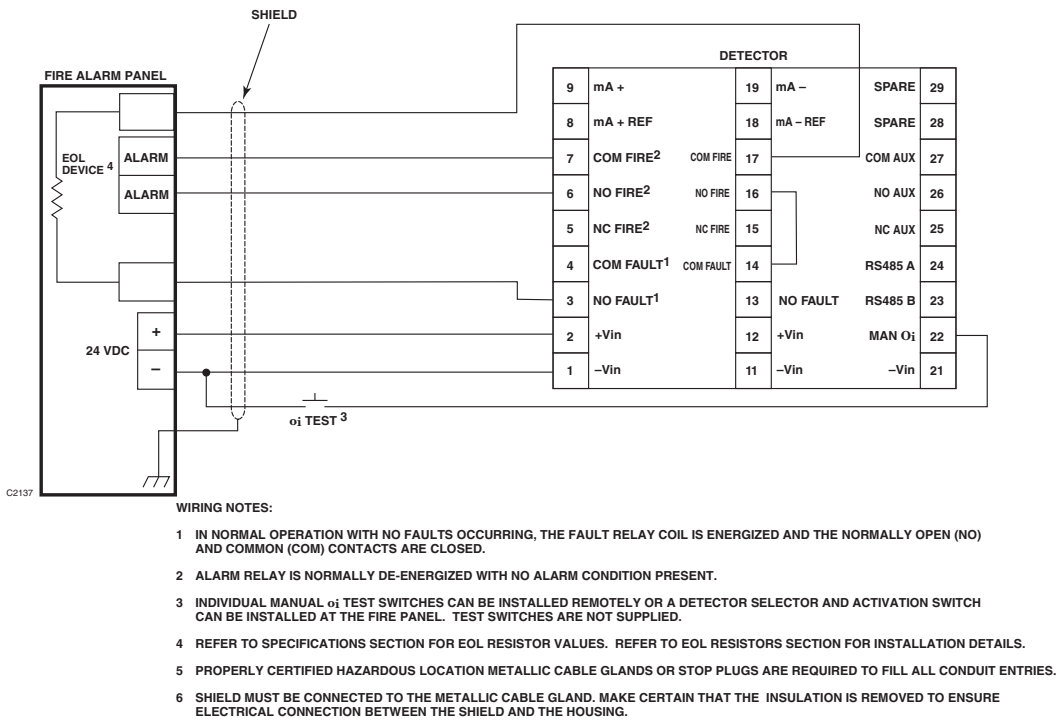

Figure 9—Ex e Wiring Option

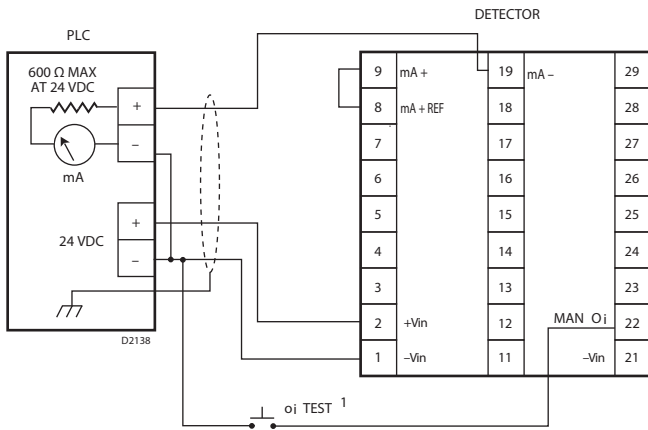

Figure 10—Detector Wired for Non-Isolated 0 to 20 mA Current Output (Sourcing)

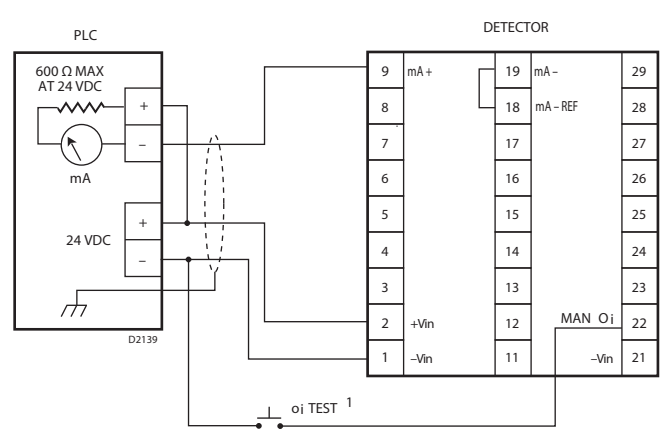

Figure 11—Detector Wired for Non-Isolated 0 to 20 mA Current Output (Sinking)

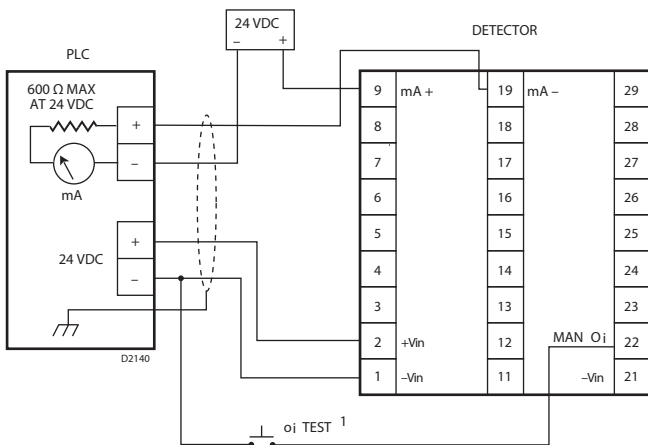

Figure 12—Detector Wired for Isolated 0 to 20 mA Current Output (Sourcing)

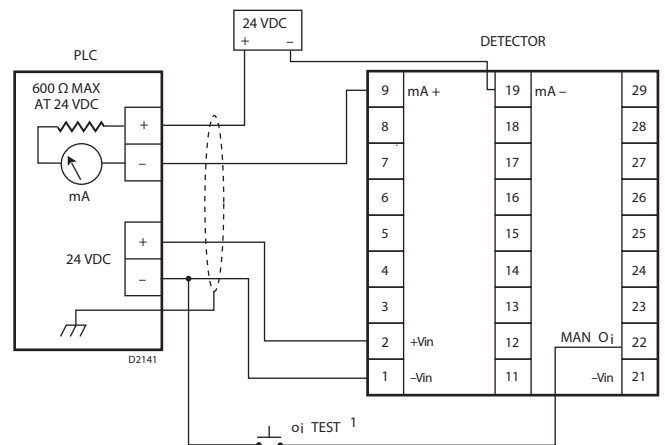

Figure 13—Detector Wired for Isolated 0 to 20 mA Current Output (Sinking)

NOTES: 1. INDIVIDUAL MANUAL oi TEST SWITCHES CAN BE INSTALLED REMOTELY OR A DETECTOR SELECTOR AND ACTIVATION SWITCH CAN BE INSTALLED AT THE FIRE PANEL. TEST SWITCHES ARE NOT SUPPLIED.

EQP Model

1. Connect external wires to the appropriate terminals inside the terminal compartment, shown in Figure 14. See Figure 15 for terminal identification.
2. Connect the shield of the power cable to earth ground at the power source.
3. Connect shields for the LON cable as indicated. See Figure 16.

NOTE

DO NOT ground any shields at the detector housing.

4. With input power disconnected, set the device network address. (See the “Setting Device Network Addresses” section of this manual for switch setting procedure.)

5. Check all field wiring to be sure that the proper connections have been made.
6. Replace and securely tighten all covers before applying input power.
7. Make the final sighting adjustments and use a 14 mm hex wrench to ensure that the mounting arm assembly is tight.

NOTE

Refer to the Eagle Quantum Premier system manual, number 95-8533, for information regarding power requirements, network communication cable requirements, and configuration.



Figure 14—Detector Terminal Block (EQP Model)

| | | | |
|---|------------|----|------------|
| 6 | SHIELD | 16 | SHIELD |
| 5 | COM 1 A | 15 | COM 2 A |
| 4 | COM 1 B | 14 | COM 2 B |
| 3 | PWR SHIELD | 13 | PWR SHIELD |
| 2 | +Vin | 12 | +Vin |
| 1 | -Vin | 11 | -Vin |

C2089

Figure 15—Wiring Terminal Identification for EQP Model

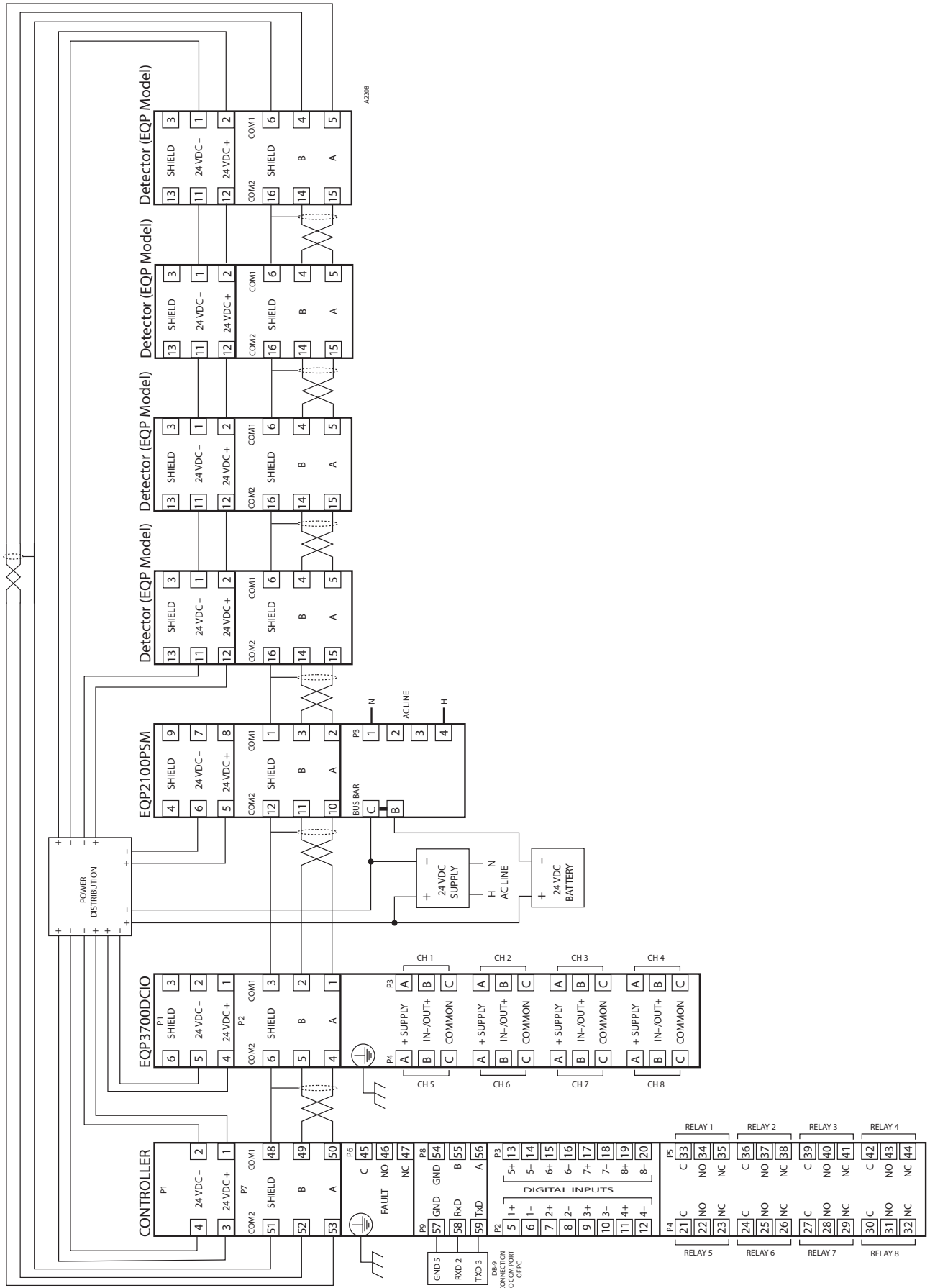

Figure 16—A Typical EQP System

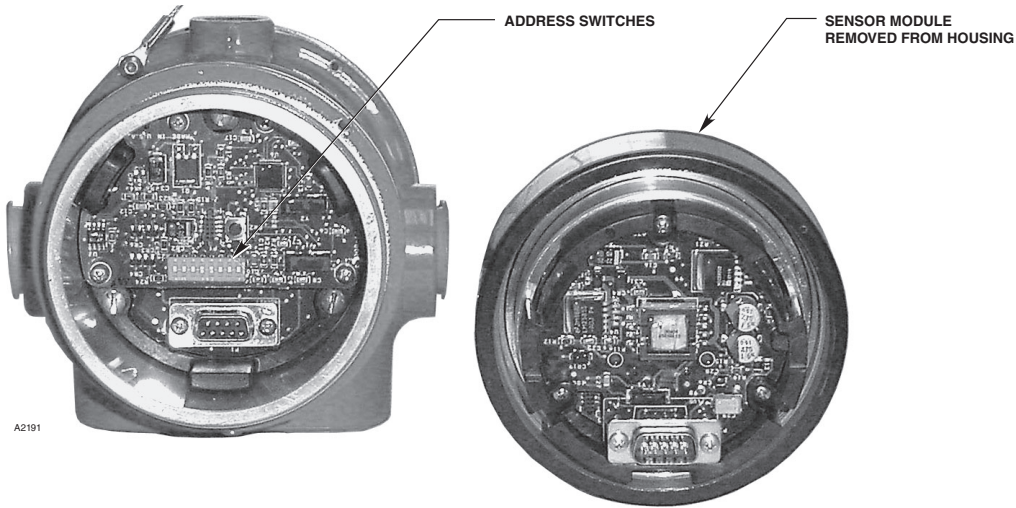

Figure 17—Location of Address Switches

SETTING DEVICE NETWORK ADDRESSES (EQ and EQP Models Only)

Overview of Network Addresses

Each device on the LON must be assigned a unique address. Addresses 1 to 4 are reserved for the controller. Valid addresses for field devices are from 5 to 250.

IMPORTANT

If the address is set to zero or an address above 250, the switch setting will be ignored.

Duplicated addresses are not automatically detected. Modules given the same address will use the number given and report to the controller using that address. The status word will show the latest update, which could be from any of the reporting modules using that address.

Setting Field Device Addresses

Selection of the node address is done by setting rocker switches on an 8 switch “DIP Switch Assembly” within the detector’s housing. Refer to Figure 17 for switch location.

WARNING

The network address switches are located within the detector housing. Removal of the sensor module (“front” half of the detector) which contains powered electrical circuits is required to gain access to the network address switches. For hazardous areas, the area must be de-classified before attempting disassembly of the device. Always observe precautions for handling electrostatic sensitive devices.

The address number is binary encoded with each switch having a specific binary value with switch 1 being the LSB (Least Significant Bit), see Figure 18. The device’s LON address is equal to the added value of all closed rocker switches. All “Open” switches are ignored.

Example: for node No. 5, close rocker switches 1 and 3 (binary values 1 + 4); for node No. 25, close rocker switches 1, 4, and 5 (binary values 1 + 8 + 16).

NOTE

*The field device sets the LON address only when power is applied to the device. Therefore, it is important to set the switches **before** applying power. If an address is ever changed, system power must be cycled before the new address will take effect.*

After setting address switches, record the address number and device type.

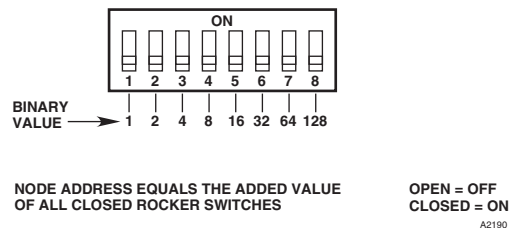

Figure 18—Address Switches for Detector

STARTUP PROCEDURE

When installation of the equipment is complete, perform the "Fire Alarm Test" below.

FIRE ALARM TEST

1. Disable any extinguishing equipment that is connected to the system.
2. Apply input power to the system.
3. Initiate an **oi** test. (See "Magnetic **oi** / Manual **oi**" under Optical Integrity in the "Description" section of this manual.)
4. Repeat this test for all detectors in the system. If a unit fails the test, refer to the "Troubleshooting" section.
5. Verify that all detectors in the system are properly aimed at the area to be protected. (The Q1201C Laser Aimer is recommended for this purpose.)
6. Enable extinguishing equipment when the test is complete and the detectors have returned to normal operation.

TROUBLESHOOTING

1. Disable any extinguishing equipment that is connected to the unit.
2. Inspect the viewing windows for contamination and clean as necessary. (Refer to the "Maintenance" section for complete information regarding cleaning of the detector viewing windows.)
3. Check input power to the unit.
4. If the fire system has a logging function, check the fire panel log for output status information. See Table 4 for information regarding 0 to 20 mA output.
5. The use of the Enhanced Flame Inspector cable and software from Det-Tronics can be considered to determine the nature of the fault condition. Refer to the instruction manual 95-8751 for more information.
6. Turn off the input power to the detector and check all wiring for continuity. **Important: Disconnect wiring at the detector before checking system wiring for continuity.**
7. If all wiring checks out and cleaning of the **oi** reflector plate/window did not correct the fault condition, check for high levels of background UV or IR radiation by covering the detector with the factory supplied cover or aluminum foil. If the fault condition clears, extreme background UV or IR radiation is present. Re-adjust the view of the detector away from the UV or IR source or relocate the detector.

Table 4—Current Level Output Troubleshooting Guide

| Current Level (±0.3 mA) | Status | Action |
|-------------------------|---|--|
| 0 mA | Power Fault | Check system wiring. |
| 1 mA | General Fault | Cycle power. ¹ |
| 2 mA | oi Fault | Clean windows. ² |
| 4 mA | Normal Operation | |
| 8 mA | Hi Background IR (IR pre-alarm) | Remove IR source or aim detector away from IR source. |
| 12 mA | Hi Background UV (UV alarm) | Remove UV source or aim detector away from UV source. |
| 14 mA | Hi Background IR (IR alarm) | Remove IR source or aim detector away from IR source. |
| 16 mA | UV and IR sensors in pre-alarm, or one in alarm and the other in pre-alarm. | If no fire exists, remove UV and IR sources or aim detector away from sources. |
| 20 mA | Fire Alarm | |

¹If fault continues, return device to factory for repair.

²See "Maintenance" section for cleaning procedure.

8. Remove the factory supplied cover or aluminum foil from the detector and verify the detector has returned to normal operation before enabling any extinguishing equipment connected to the unit.

If none of these actions corrects the problem, please contact your local Det-Tronics Representative or alternately you may contact Det-Tronics Technical Support by calling 1-800-765-3473 to obtain assistance.

NOTE

It is highly recommended that a complete spare be kept on hand for field replacement to ensure continuous protection.

MAINTENANCE

IMPORTANT

Periodic flamepath inspections are not recommended, since the product is not intended to be serviced and provides proper ingress protection to eliminate potential deterioration of the flamepaths.

⚠ WARNING

To avoid a potential electrostatic discharge (ESD), the painted surface of the detector should only be cleaned with a damp cloth.

⚠ WARNING

The sensor module ("front" half of the detector) contains no user serviceable components and should never be tampered with.

NOTE

Refer to the X5200 Safety manual (95-8672) for specific requirements and recommendations applicable to the proper installation, operation, and maintenance of all SIL-Certified X5200/X5200G Flame Detectors.

To maintain maximum sensitivity and false alarm resistance, the viewing windows of the detector must be kept relatively clean. Refer to the following procedure for cleaning instructions.

CLEANING PROCEDURE

⚠ CAUTION

Disable any extinguishing equipment that is connected to the unit to prevent unwanted actuation.

To clean the windows and **oi** reflector plate, use the window cleaner (p/n 001680-001) with a soft cloth, cotton swab, or tissue and refer to the following procedure:

1. **Disable any extinguishing equipment that is connected to the unit.**

NOTE

Remove input power when cleaning the detector windows. The rubbing motion on the surface of the windows during cleaning can create static electricity that could result in unwanted output activation.

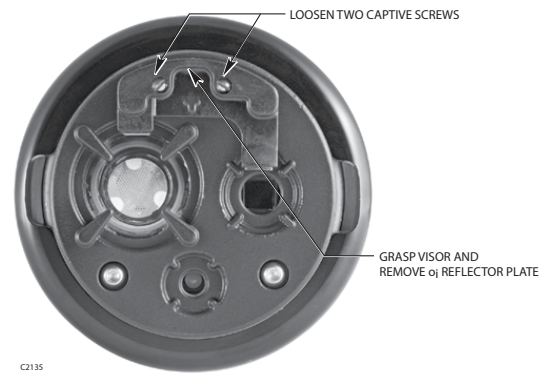

Figure 19—**oi** Reflector Plate Removal

2. Clean the viewing windows and reflective surfaces of the **oi** reflector plate using a clean cloth, cotton swab, or tissue with the window cleaning solution. Use Isopropyl alcohol for contaminations that the window cleaning solution can not remove. If a fault condition is still indicated after cleaning, remove and clean the **oi** reflector plate using the **oi** Reflector Plate Removal and Replacement procedure.

IMPORTANT

When used in extreme environments, the reflective surface of the detector **oi** reflector plate may eventually deteriorate, resulting in reoccurring **oi** faults and the need for **oi** reflector plate replacement.

oi REFLECTOR PLATE REMOVAL AND REPLACEMENT

1. **Disable any extinguishing equipment that is connected to the unit.**
2. Loosen the two captive screws, then grasp the **oi** reflector plate by the visor and remove it from the detector. See Figure 19.
3. Install the new (or cleaned) **oi** reflector plate.
4. Recalibrate the detector's **oi** system. Refer to the Enhanced Flame Inspector manual (95-8751) for instructions regarding **oi** reflector plate replacement and **oi** system recalibration.

⚠ CAUTION

Do not replace the **oi reflector plate without also recalibrating the **oi** system.**

Recalibration of the **oi** system requires the use of the Inspector Connector Cable and Inspector Monitor Software. These two items are included in the **oi** replacement kit, or they can be purchased separately. See the "Ordering Information" section for details.

PERIODIC CHECKOUT PROCEDURE

In compliance with SIL 2, a checkout of the system using the Mag **oi** or Man **oi** feature should be performed regularly to ensure that the system is operating properly. Refer to Table 1 in the X5200/X5200G Safety manual (95-8672) for frequency of proof tests. To test the system, perform the "Fire Alarm Test" as described in the "Startup Procedure" section of this manual.

CLOCK BATTERY

The real time clock has a backup battery that will operate the clock with no external power. Return the device to the factory for battery replacement if needed.

NOTE

If the backup battery is depleted, there is no effect on the operation of the flame detector, but the time stamping of the data log may be affected.

FEATURES

- Responds to a fire in the presence of modulated blackbody radiation (i.e., heaters, ovens, turbines) without false alarm
- High speed capability
- Built-in data logging / event monitoring, up to 1500 events (up to 1000 general, 500 alarms)
- Microprocessor controlled heated optics for increased resistance to moisture and ice
- Automatic, manual, or magnetic **oi** testing
- Easily replaceable **oi** reflector plate
- Fire, fault, and auxiliary relays standard
- 0 to 20 mA isolated output (optional)
- Eagle Quantum Premier LON/SLC output (optional)
- HART communication (optional)
- FDT/DTM capable
- A tri-color LED on the detector faceplate indicates normal condition and notifies personnel of fire alarm or fault conditions
- Operates under adverse weather conditions
- Mounting arm allows easy sighting
- Integral wiring compartment for ease of installation
- Explosion-proof/flame-proof detector housing. Meets FM, CSA, ATEX, and IECEx certification requirements.
- Class A wiring per NFPA-72
- Meets NFPA-33 response requirement for under 0.5 second (available when model selected)
- 3 year warranty
- Advanced signal processing (ARC/TDSA)
- RFI and EMC Directive compliant

Associated Manuals

List of related manuals:

| TITLE | FORM NUMBER |
|--|-------------|
| Pulse | 95-8547 |
| EQP | 95-8533 |
| SIL 2 (Safety) | 95-8672 |
| HART Addendum | 95-8636 |
| Q9033 Mounting Arm and Collar Attachment | 95-8686 |
| Enhanced Flame Inspector Software for X-Series Flame Detectors | 95-8751 |

SPECIFICATIONS

OPERATING VOLTAGE—

24 Vdc nominal (18 Vdc minimum, 30 Vdc maximum).
Maximum ripple is 2 volts peak-to-peak.

POWER CONSUMPTION—

Without heater: 2.8 watts at 24 Vdc nominal;
4.8 watts at 24 Vdc in alarm.
3.1 watts at 30 Vdc nominal;
5.4 watts at 30 Vdc in alarm.

Heater only: 8 watts maximum.
Total power: 17.5 watts at 30 Vdc with EOL resistor installed and heater on maximum.

For HART models, refer to Addendum number 95-8636.

POWER UP TIME—

Fault indication clears after 0.5 second; device is ready to indicate an alarm condition after 30 seconds.

OUTPUT RELAYS—

Fire Alarm relay, Form C, 5 amperes at 30 Vdc:

The Fire Alarm relay has redundant terminals and normally open / normally closed contacts, normally de-energized operation, and latching or non-latching operation.

Fault relay, Form A, 5 amperes at 30 Vdc:

The Fault relay has redundant terminals and normally open contacts, normally energized operation, and latching or non-latching operation.

Auxiliary relay, Form C, 5 amperes at 30 Vdc:

The auxiliary relay has normally open / normally closed contacts, normally energized or de-energized operation, and latching or non-latching operation.

CURRENT OUTPUT (Optional)—

0 to 20 milliampere (± 0.3 mA) dc current, with a

100% REPRESENTS THE MAXIMUM DETECTION DISTANCE FOR A GIVEN FIRE. THE SENSITIVITY INCREASES AS THE ANGLE OF INCIDENCE DECREASES.

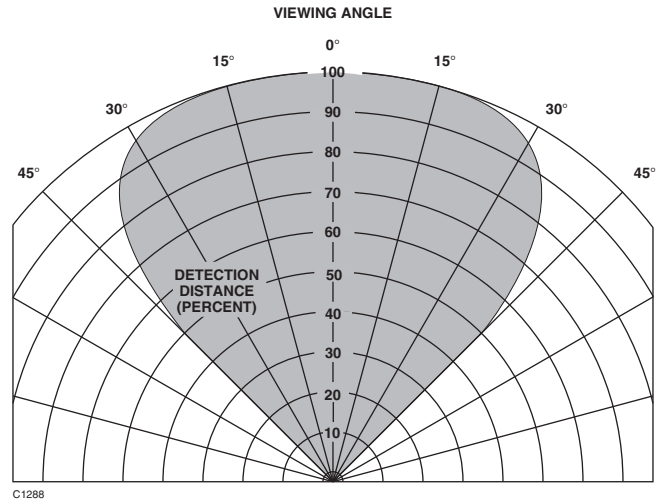

Figure 20—Detector Cone of Vision

maximum loop resistance of 500 ohms from 18 to 19.9 Vdc and 600 ohms from 20 to 30 Vdc.

LON OUTPUT—

Digital communication, transformer isolated (78.5 kbps).

TEMPERATURE RANGE—

Operating: -40°F to $+167^{\circ}\text{F}$ (-40°C to $+75^{\circ}\text{C}$).
Storage: -67°F to $+185^{\circ}\text{F}$ (-55°C to $+85^{\circ}\text{C}$).
Hazardous location ratings from -55°C to $+75^{\circ}\text{C}$ available on flameproof model.

HUMIDITY RANGE—

0 to 95% relative humidity, can withstand 100% condensing humidity for short periods of time.

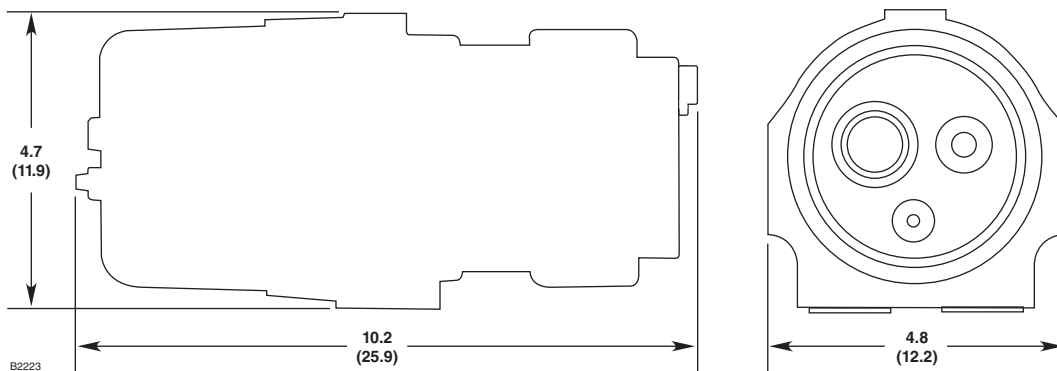

Figure 21—Dimensions in Inches (cm)

CONE OF VISION—

The detector has a 90° cone of vision (horizontal) with the highest sensitivity lying along the central axis. See Figure 20.

RESPONSE TIME—

32 inch methane plume: < 10 seconds.
1 foot x 1 foot n-Heptane: < 15 seconds.
(See Appendix A for details.)

SOURCE TUBE—

Contains radioactive isotope Krypton 85 (Kr⁸⁵)
Calculated Activity: 14,800 Becquerels (0.4µCi).
Note: Not applicable to model X5200G

ENCLOSURE MATERIAL—

Copper-free aluminum (painted) or Stainless Steel (316/CF8M Cast).

VIBRATION—

Conformance per FM 3260: 2018, MIL-STD 810C (Curve AW).

DIMENSIONS—

See Figure 21.

WIRING—

Field wiring screw terminals are UL/CSA rated for up to 14 AWG wire, and are DIN/VDE rated for 2.5 mm² wire. Screw terminal required torque is 3.5 in.-lbs. (0.4 N·m).

Important: 18 Vdc minimum must be available at the detector. For ambient temperatures below -10°C (14°F) and above +60°C (140°F) use field wiring suitable for both minimum and maximum ambient temperature.

THREAD SIZE—

Conduit connection: Four entries, 3/4 inch NPT or M25.
Conduit seal not required.

SHIPPING WEIGHT (Approximate)—

Aluminum: 7 pounds (3.2 kilograms).
Stainless Steel: 14.6 pounds (6.7 kilograms).
Mounting Arm (AL): 6 pounds (2.75 kilograms).
Mounting Arm (SS): 14 pounds (6.4 kilograms).

WARRANTY PERIOD—

3 years

CERTIFICATION—



For complete approval details, refer to the appropriate Appendix:

- Appendix A - FM
- Appendix B - CSA
- Appendix C - ATEX
- Appendix D - IECEx
- Appendix E - EN54
- Appendix F - Additional Approvals
- Appendix G - Declaration of Conformity

REPLACEMENT PARTS

Certain parts (see table below) of the detector can be replaced if needed.

REPLACEMENT PARTS LIST

| Part Number | Description |
|-------------|--|
| 009208-002 | oj Replacement kit for X52/X22/X98 (5 Reflector Plates) with Inspector Connector and Monitor |
| 007307-002 | Replacement oj Reflector Plate for X52/X22/X98 (requires Inspector Connector to calibrate) |

DEVICE REPAIR AND RETURN

The detector is not designed to be repaired in the field. If a problem should develop, refer to the "Troubleshooting" section. If it is determined that the problem is caused by an electronic defect, the device must be returned to the factory for repair.

Prior to returning devices, a Return Materials Authorization (RMA) number must be obtained. The process for obtaining this number can be found [here](#). You may also contact your [authorized local sales representative](#) or Det-Tronics Technical Support for assistance:

1.800.765.3473, ext.3 (M-F, 8 AM - 5 PM, Central Prevailing Time)
RMA@Det-Tronics.com

When items are being returned, please note:

NOTE

Shipments received without an RMA number clearly marked on the outside of the shipment will be refused.

NOTE

Shipping personnel must be hazmat trained to pack, mark, and label the return package. Please consult your country-specific regulations.

Pack the unit properly. Always use sufficient packing material. Where applicable, use an antistatic bag as protection from electrostatic discharge.

NOTE

Det-Tronics reserves the right to apply a service charge for repairing returned product damaged as a result of improper packaging.

Return all equipment transportation prepaid to the factory in Minneapolis.

NOTE

It is highly recommended that a complete spare be kept on hand for field replacement to ensure continuous protection.

NOTE

*Radioactive material is subject to regulation. All products containing a source tube meet the definition of an "excepted package" for radioactive material under the US Department of Transportation (DOT), the International Air Transport Association (IATA), the International Civil Aviation Organization (ICAO), the International Maritime Dangerous Goods Code (IMDG), and any other specific hazardous material regulations from the country of source of return (TDG, RID, ADR, etc.). These units are classified as "UN2911, Radioactive Material, Excepted Package – Article." **Not applicable to model X5200G; not subjected to UN2911 Classification.***

ORDERING INFORMATION

When ordering, please specify:
 X5200, X5200G, or X5200M UVIR Flame Detector
 Refer to the X5200 Series Model Matrix below for details
 Q9033 Mounting Arm is required:

- Q9033A for aluminum detectors only
- Q9033B for aluminum and stainless steel detectors

ACCESSORIES

| Part Number | Description |
|-------------|--|
| 000511-029 | Converter RS485 to RS232 |
| 103881-001 | Converter RS485 to USB |
| 007819-002 | W6300B1003 USB Inspector Connector (Flame Inspector software included) |
| 009207-001 | Flame Inspector CD |
| 103922-003 | AMS Trex HART Communicator |
| 102740-002 | Magnet |
| 008082-001 | Magnet and Adapter for Extension Pole |
| 007739-001 | Magnet and Extension Pole |
| 007240-001 | Q1116A1001, Air Shield (AL) |
| 007818-001 | Q1118A1001 Aluminum Air Shield/Flange Mount (AL) |
| 007818-002 | Q1118S1001 Stainless Steel Air Shield/Flange Mount (SS) |
| 009177-001 | Q1120A1001 Paint Shield mounting ring (AL) |
| 006097-002 | Q1201 Green Laser |
| 102871-001 | Laser Battery, 3V Lithium (laser) |
| 007255-001 | Q1201C1001 X-Series Laser Holder (AL/Plastic) |
| 007338-001 | Q2000A1001 X-Series Weather Shield (AL) |
| 007290-001 | Q9033B Stainless Steel Mounting Arm Assembly is for aluminum and stainless steel detectors |
| 007290-002 | Q9033A Aluminum Mounting Arm Assembly is for aluminum detectors only |
| 011385-001 | Q9033 Collar Attachment |
| 101197-001 | Stop Plug, 3/4" NPT, AL |
| 101197-004 | Stop Plug, 3/4" NPT, SS |
| 101197-005 | Stop Plug, M25, AL, IP66 |
| 101197-003 | Stop Plug, M25, SS, IP66 |
| 010816-001 | Stop Plug, 20 Pack, 3/4"NPT, AL |
| 010817-001 | Stop Plug, 20 Pack, 3/4"NPT, SS |
| 010818-001 | Stop Plug, 20 Pack, M25, AL, IP66 |
| 010819-001 | Stop Plug, 20 Pack, M25, SS, IP66 |
| 103363-001 | 14 mm Hex Wrench (Steel) |
| 103406-001 | Screwdriver |
| 001680-001 | Window cleaner (6 pack) |
| 107427-040 | O-ring - Rear Cover (Viton) - black or brown |
| 005003-001 | 1 oz grease for detectors (silicone-free) |
| 104346-154 | O-ring - Rear Cover (Fluorosilicone) - blue |
| 012549-001 | 1 oz PTFE silicone-free lubricant |

X5200 SERIES MODEL MATRIX

| MODEL | DESCRIPTION | | | | | | | | | | | | | | |
|---------------|---|------|----------------|-----------|-----------------------|-----------|-----------------------|-----------|-----------------------------|-----------|-----------------|-----------|--------------------------|-----------|------------------|
| X5200 | UV/IR Flame Detector | | | | | | | | | | | | | | |
| X5200G | UV/IR Flame Detector with Kr ⁸⁵ Free Source Tube | | | | | | | | | | | | | | |
| X5200M | UV/IR Flame Detector with Molybdenum Tube | | | | | | | | | | | | | | |
| | <table border="1"> <thead> <tr> <th>TYPE</th> <th>MATERIAL</th> </tr> </thead> <tbody> <tr> <td>A</td> <td>Aluminum</td> </tr> <tr> <td>S</td> <td>Stainless Steel (316)</td> </tr> </tbody> </table> | TYPE | MATERIAL | A | Aluminum | S | Stainless Steel (316) | | | | | | | | |
| TYPE | MATERIAL | | | | | | | | | | | | | | |
| A | Aluminum | | | | | | | | | | | | | | |
| S | Stainless Steel (316) | | | | | | | | | | | | | | |
| | <table border="1"> <thead> <tr> <th>TYPE</th> <th>THREAD TYPE</th> </tr> </thead> <tbody> <tr> <td>4M</td> <td>4 Port, Metric M25</td> </tr> <tr> <td>4N</td> <td>4 Port, 3/4" NPT</td> </tr> </tbody> </table> | TYPE | THREAD TYPE | 4M | 4 Port, Metric M25 | 4N | 4 Port, 3/4" NPT | | | | | | | | |
| TYPE | THREAD TYPE | | | | | | | | | | | | | | |
| 4M | 4 Port, Metric M25 | | | | | | | | | | | | | | |
| 4N | 4 Port, 3/4" NPT | | | | | | | | | | | | | | |
| | <table border="1"> <thead> <tr> <th>TYPE</th> <th>OUTPUTS</th> </tr> </thead> <tbody> <tr> <td>11</td> <td>Relay</td> </tr> <tr> <td>13</td> <td>Relay and 0-20 mA</td> </tr> <tr> <td>14</td> <td>Eagle Quantum Premier (EQP)</td> </tr> <tr> <td>15</td> <td>Relay and Pulse</td> </tr> <tr> <td>23</td> <td>HART, Relay and 0-20 mA</td> </tr> <tr> <td>24</td> <td>Eagle Quantum</td> </tr> </tbody> </table> | TYPE | OUTPUTS | 11 | Relay | 13 | Relay and 0-20 mA | 14 | Eagle Quantum Premier (EQP) | 15 | Relay and Pulse | 23 | HART, Relay and 0-20 mA | 24 | Eagle Quantum |
| TYPE | OUTPUTS | | | | | | | | | | | | | | |
| 11 | Relay | | | | | | | | | | | | | | |
| 13 | Relay and 0-20 mA | | | | | | | | | | | | | | |
| 14 | Eagle Quantum Premier (EQP) | | | | | | | | | | | | | | |
| 15 | Relay and Pulse | | | | | | | | | | | | | | |
| 23 | HART, Relay and 0-20 mA | | | | | | | | | | | | | | |
| 24 | Eagle Quantum | | | | | | | | | | | | | | |
| | <table border="1"> <thead> <tr> <th>TYPE</th> <th>APPROVALS*</th> </tr> </thead> <tbody> <tr> <td>T</td> <td>SIL/FM/CSA/ATEX/IECEX</td> </tr> <tr> <td>W</td> <td>FM/CSA/ATEX/IECEX</td> </tr> <tr> <td>S</td> <td>SIL</td> </tr> <tr> <td>E</td> <td>ATEX/IECEX</td> </tr> <tr> <td>R</td> <td>VNIIP0/VNIIFTRI (Russia)</td> </tr> <tr> <td>B</td> <td>INMETRO (Brazil)</td> </tr> </tbody> </table> | TYPE | APPROVALS* | T | SIL/FM/CSA/ATEX/IECEX | W | FM/CSA/ATEX/IECEX | S | SIL | E | ATEX/IECEX | R | VNIIP0/VNIIFTRI (Russia) | B | INMETRO (Brazil) |
| TYPE | APPROVALS* | | | | | | | | | | | | | | |
| T | SIL/FM/CSA/ATEX/IECEX | | | | | | | | | | | | | | |
| W | FM/CSA/ATEX/IECEX | | | | | | | | | | | | | | |
| S | SIL | | | | | | | | | | | | | | |
| E | ATEX/IECEX | | | | | | | | | | | | | | |
| R | VNIIP0/VNIIFTRI (Russia) | | | | | | | | | | | | | | |
| B | INMETRO (Brazil) | | | | | | | | | | | | | | |
| | <table border="1"> <thead> <tr> <th>TYPE</th> <th>CLASSIFICATION</th> </tr> </thead> <tbody> <tr> <td>1</td> <td>Division/Zone Ex d e</td> </tr> <tr> <td>2</td> <td>Division/Zone Ex d</td> </tr> </tbody> </table> | TYPE | CLASSIFICATION | 1 | Division/Zone Ex d e | 2 | Division/Zone Ex d | | | | | | | | |
| TYPE | CLASSIFICATION | | | | | | | | | | | | | | |
| 1 | Division/Zone Ex d e | | | | | | | | | | | | | | |
| 2 | Division/Zone Ex d | | | | | | | | | | | | | | |

*Type Approvals can use one or more letters to designate the approvals of the product.

APPENDIX A

FM APPROVAL AND PERFORMANCE REPORT

THE FOLLOWING ITEMS, FUNCTIONS, AND OPTIONS DESCRIBE THE FM APPROVAL FOR THE X5200, X5200G AND X5200M:

- Explosion-proof for Class I, Div. 1, Groups B, C, and D (T5) Hazardous (Classified) Locations per FM 3615.
- Dust-ignition proof for Class II/III, Div. 1, Groups E, F, and G (T5) Hazardous (Classified) Locations per FM 3615.
- Nonincendive for Class I, Div. 2, Groups A, B, C, and D (T3) Hazardous (Classified) Locations per FM 3611.
- Nonincendive for Class II, Div. 2, Groups F and G (T3) Hazardous (Classified) Locations per FM 3611.
- Enclosure rating NEMA/Type 4X per NEMA 250.
- Ambient Temperature Limits: -40°F to +167°F (-40°C to +75°C).
- Automatic Fire Alarm Signaling Performance verified per FM 3260 (2018).

Flameproof per ANSI/ISA 60079-0, -1, -7, -31

Class I, Zone 1, AEx db eb IIC T6...T5

T6 (Tamb -40°C to +60°C)

T5 (Tamb -40°C to +75°C)

Zone 21, AEx tb IIIC T80°C

Tamb -40°C to +75°C

IP66/IP67

Class I, Zone 1, AEx db IIC T6...T5

T6 (Tamb -40°C to +60°C)

T5 (Tamb -40°C to +75°C)

Zone 21, AEx tb IIIC T80°C

Tamb -40°C to +75°C

IP66/IP67

The following accessories are FM approved for use with the X5200, X5200G and X5200M Flame Detectors:

| Part Number | Description |
|-------------|--|
| 102740-002 | Magnet |
| 007739-001 | Magnet and Extension Pole |
| 007290-001 | Q9033B Stainless Steel Mounting Arm Assembly is for aluminum and stainless steel detectors |
| 007290-002 | Q9033A Aluminum Mounting Arm Assembly is for aluminum detectors only |
| 011385-001 | Q9033 Collar Attachment |

The following performance criteria were verified:

AUTOMATIC OPTICAL INTEGRITY TEST:

The detector generated an optical fault in the presence of contamination on any single or combination of lens surfaces resulting in a loss of approximately 50% of its detection range, verifying that the detector performs a calibrated Automatic **oi** test for each sensor. Upon removal of the contamination, the detector fault was cleared and the detector was verified to detect a fire.

MANUAL OPTICAL INTEGRITY TEST:

The Manual / Magnetic **oi** performs the same calibrated test as the Automatic **oi**, and additionally actuates the alarm relay to verify output operation. If there is a 50% loss of its detection range, an alarm signal is not generated.

The **oi** test procedure, as described in the "Magnetic **oi** / Manual **oi**" section of this instruction manual, is the approved external optical test method for this detector to verify end-to-end detector function. This test replaces the function and need of a traditional external test lamp.

X5200 and X5200G RESPONSE CHARACTERISTICS

High Sensitivity UV & IR, Hi Arc, TDSA On, Quick Fire Off

| Fuel | Size | Distance feet (m) | Average Response Time (seconds)* |
|-----------|---------------|-------------------|----------------------------------|
| n-Heptane | 1 x 1 foot | 50 (15.2) | 7 |
| Methane | 32 inch plume | 35 (10.7) | 3.5 |

*Add 2 seconds for EQP model.

High Sensitivity UV & IR, Very Hi Arc, TDSA On, Quick Fire Off

| Fuel | Size | Distance feet (m) | Average Response Time (seconds)* |
|-----------|------------|-------------------|----------------------------------|
| n-Heptane | 1 x 1 foot | 50 (15.2) | 8 |

*Add 2 seconds for EQP model.

High Sensitivity UV & IR, Very Hi Arc, TDSA On, Quick Fire On

| Fuel | Size | Distance feet (m) | Average Response Time (seconds)* |
|-----------|------------|-------------------|----------------------------------|
| n-Heptane | 1 x 1 foot | 50 (15.2) | 8 |

*Add 2 seconds for EQP model.

High Sensitivity UV, Low Sens. IR, Hi Arc, TDSA On, Quick Fire Off

| Fuel | Size | Distance feet (m) | Average Response Time (seconds)* |
|-----------|------------|-------------------|----------------------------------|
| n-Heptane | 1 x 1 foot | 15 (4.6) | 9 |

*Add 2 seconds for EQP model.

High Sensitivity UV, Very High Sens. IR, Arc Off, TDSA On, Quick Fire On

| Fuel | Size | Distance feet (m) | Average Response Time (seconds)* |
|---------|---------------|-------------------|----------------------------------|
| Methane | 32 inch plume | 15 (4.6) | 0.12 |

*Add 2 seconds for EQP model.

High Sensitivity UV, Very High Sens. IR, Hi Arc, TDSA On, Quick Fire On

| Fuel | Size | Distance feet (m) | Average Response Time (seconds)* |
|---------|---------------|-------------------|----------------------------------|
| Methane | 32 inch plume | 15 (4.6) | 0.3 |

*Add 2 seconds for EQP model.

Very High Sensitivity UV & IR, Low Arc, TDSA On, Quick Fire On

| Fuel | Size | Distance feet (m) | Average Response Time (seconds)* |
|-----------|---------------|-------------------|----------------------------------|
| n-Heptane | 1 x 1 foot | 85 (25.9) | 14 |
| Methane | 32 inch plume | 65 (19.8) | 5 |

*Add 2 seconds for EQP model.

High Sensitivity UV, Very High Sensitivity IR, Hi Arc, TDSA On, Quick Fire Off

| Fuel | Size | Distance feet (m) | Average Response Time (seconds)* |
|-----------|---------------|-------------------|----------------------------------|
| n-Heptane | 1 x 1 foot | 60 (18.3) | 6 |
| Methane | 32 inch plume | 65 (19.8) | 9 |

*Add 2 seconds for EQP model.

Medium Sensitivity UV, High Sensitivity IR, Hi Arc, TDSA On, Quick Fire On

| Fuel | Size | Distance feet (m) | Average Response Time (seconds)* |
|-----------|---------------|-------------------|----------------------------------|
| n-Heptane | 1 x 1 foot | 50 (15.2) | 5 |
| Methane | 32 inch plume | 60 (18.3) | 5 |

*Add 2 seconds for EQP model.

FM Approval and Performance Report – Continued

X5200 and X5200G RESPONSE CHARACTERISTICS IN THE PRESENCE OF FALSE ALARM SOURCES

High Sensitivity, Hi Arc, TDSA On, Quick Fire Off

| False Alarm Source | Distance feet (m) | Fire Source | Distance feet (m) | Average Response Time (seconds)* |
|---|-------------------|--------------------|-------------------|----------------------------------|
| Sunlight, direct, modulated/unmodulated | — | 2 inch dia Heptane | 10 (3) | < 30 |
| Sunlight, reflected, modulated/unmodulated | — | 2 inch dia Heptane | 10 (3) | < 30 |
| 70 w sodium vapor lamp, unmodulated | 5 (1.5) | 2 inch dia Heptane | 5 (1.5) | 3 |
| 70 w sodium vapor lamp, modulated | 5 (1.5) | 2 inch dia Heptane | 5 (1.5) | 3 |
| 250 w mercury vapor lamp, unmodulated | 5 (1.5) | 2 inch dia Heptane | 5 (1.5) | 2 |
| 250 w mercury vapor lamp, modulated | 5 (1.5) | 2 inch dia Heptane | 5 (1.5) | 3 |
| 300 w incandescent lamp, unmodulated | 5 (1.5) | 2 inch dia Heptane | 5 (1.5) | 4 |
| 300 w incandescent lamp, modulated | 5 (1.5) | 2 inch dia Heptane | 5 (1.5) | 3 |
| 500 w shielded quartz halogen lamp, unmodulated | 5 (1.5) | 2 inch dia Heptane | 5 (1.5) | 2 |
| 500 w shielded quartz halogen lamp, modulated | 5 (1.5) | 2 inch dia Heptane | 5 (1.5) | 2 |
| 1500 w electric quartz heater, unmodulated | 10 (3) | 2 inch dia Heptane | 5 (1.5) | 3 |
| 1500 w electric quartz heater, modulated | 10 (3) | 2 inch dia Heptane | 3 (0.9) | 11 |
| Two 34 w fluorescent lamps, unmodulated | 3 (0.9) | 2 inch dia Heptane | 10 (3) | 3 |
| Two 34 w fluorescent lamps, modulated | 3 (0.9) | 2 inch dia Heptane | 10 (3) | 5 |
| Arc welding | 15 (4.6) | 2 inch dia Heptane | 5 (1.5) | N/A |

*Add 2 seconds for EQP model.

X5200 and X5200G FALSE ALARM IMMUNITY

High Sensitivity, Hi Arc, TDSA On, Quick Fire Off

| False Alarm Source | Distance feet (m) | Modulated Response | Unmodulated Response |
|------------------------------------|-------------------|--------------------|----------------------|
| Sunlight, direct, reflected | — | No alarm | No alarm |
| Vibration | N/A | No alarm | No alarm |
| Arc welding | 15 (4.6) | No alarm | No alarm |
| 70 w sodium vapor lamp | 3 (0.9) | No alarm | No alarm |
| 250 w mercury vapor lamp | 3 (0.9) | No alarm | No alarm |
| 300 w incandescent lamp | 3 (0.9) | No alarm | No alarm |
| 500 w shielded quartz halogen lamp | 3 (0.9) | No alarm | No alarm |
| 1500 w electric quartz heater | 10 (3) | No alarm | No alarm |
| Two 34 w fluorescent lamps | 3 (0.9) | No alarm | No alarm |

FM Approval and Performance Report – Continued

X5200 and X5200G Field of view

High Sensitivity UV & IR, Hi Arc, TDSA On, Quick Fire Off

| Fuel | Size | Distance feet (m) | Horizontal (degrees) | Average Horz. Response Time (seconds)* | Vertical (degrees) | Average Vert. Response Time (seconds)* |
|-----------|---------------|-------------------|----------------------|--|--------------------|--|
| n-Heptane | 1 x 1 foot | 25 | +45 | 5 | +45 | 4 |
| | | (7.6) | -45 | 8 | -30 | 8 |
| Methane | 32 inch plume | 17.5 | +45 | 3 | +45 | 4 |
| | | (5.3) | -45 | 4 | -30 | 4 |

*Add 2 seconds for EQP model.

High Sensitivity UV & IR, Very Hi Arc, TDSA On, Quick Fire On

| Fuel | Size | Distance feet (m) | Horizontal (degrees) | Average Horz. Response Time (seconds)* | Vertical (degrees) | Average Vert. Response Time (seconds)* |
|-----------|------------|-------------------|----------------------|--|--------------------|--|
| n-Heptane | 1 x 1 foot | 25 | +45 | 12 | +45 | 13 |
| | | (7.6) | -45 | 9 | -30 | 6 |

*Add 2 seconds for EQP model.

High Sensitivity UV, Low Sensitivity IR, Hi Arc, TDSA On, Quick Fire Off

| Fuel | Size | Distance feet (m) | Horizontal (degrees) | Average Horz. Response Time (seconds)* | Vertical (degrees) | Average Vert. Response Time (seconds)* |
|-----------|------------|-------------------|----------------------|--|--------------------|--|
| n-Heptane | 1 x 1 foot | 7.5 | +45 | 6 | +45 | 9 |
| | | (2.2) | -45 | 6 | -30 | 6 |

*Add 2 seconds for EQP model.

High Sensitivity UV, Very High Sensitivity IR, Arc Off, TDSA On, Quick Fire On

| Fuel | Size | Distance feet (m) | Horizontal (degrees) | Average Horz. Response Time (seconds)* | Vertical (degrees) | Average Vert. Response Time (seconds)* |
|---------|---------------|-------------------|----------------------|--|--------------------|--|
| Methane | 32 inch plume | 7.5 | +45 | 0.9 | +45 | 0.1 |
| | | (2.2) | -45 | 0.2 | -30 | 0.1 |

*Add 2 seconds for EQP model.

Very High Sensitivity UV & IR, Low Arc, TDSA On, Quick Fire On

| Fuel | Size | Distance feet (m) | Horizontal (degrees) | Average Horz. Response Time (seconds)* | Vertical (degrees) | Average Vert. Response Time (seconds)* |
|-----------|---------------|-------------------|----------------------|--|--------------------|--|
| n-Heptane | 1 x 1 foot | 42.5 | +45 | 12 | +45 | 11 |
| | | (13) | -45 | 14 | -30 | 13 |
| Methane | 32 inch plume | 32.5 | +45 | 5 | +45 | 6 |
| | | (9.9) | -45 | 7 | -30 | 6 |

*Add 2 seconds for EQP model.

High Sensitivity UV, Very High Sensitivity IR, Hi Arc, TDSA On, Quick Fire Off

| Fuel | Size | Distance feet (m) | Horizontal (degrees) | Average Horz. Response Time (seconds)* | Vertical (degrees) | Average Vert. Response Time (seconds)* |
|-----------|---------------|-------------------|----------------------|--|--------------------|--|
| n-Heptane | 1 x 1 foot | 30 | +45 | 8 | +45 | 10 |
| | | (9.1) | -45 | 8 | -30 | 7 |
| Methane | 32 inch plume | 32.5 | +45 | 4 | +45 | 5 |
| | | (9.9) | -45 | 5 | -30 | 5 |

*Add 2 seconds for EQP model.

Medium Sensitivity UV, High Sensitivity IR, Hi Arc, TDSA On, Quick Fire On

| Fuel | Size | Distance feet (m) | Horizontal (degrees) | Average Horz. Response Time (seconds)* | Vertical (degrees) | Average Vert. Response Time (seconds)* |
|-----------|---------------|-------------------|----------------------|--|--------------------|--|
| n-Heptane | 1 x 1 foot | 25 | +45 | 15 | +45 | 7 |
| | | (7.6) | -45 | 7 | -30 | 9 |
| Methane | 32 inch plume | 30 | +45 | 8 | +45 | 8 |
| | | (9.1) | -45 | 6 | -30 | 12 |

*Add 2 seconds for EQP model.

FM Approval and Performance Report – Continued

MODEL X5200M

The X5200M uses a sensor that has a broader spectrum than the standard sensor. It is designed to detect fires with unusual chemistry such as black powder. Consult factory for usage recommendations.

X5200M RESPONSE CHARACTERISTICS

High Sensitivity UV & IR, Arc Off, TDSA On, Quick Fire On

| Fuel | Size | Distance feet (m) | Average Response Time (seconds) |
|--------------|----------|-------------------|---------------------------------|
| Black Powder | 40 grams | 10 (3) | 0.12 |

X5200M RESPONSE CHARACTERISTICS IN THE PRESENCE OF FALSE ALARMS

High Sensitivity UV & IR, Arc Off, TDSA On, Quick Fire On

| False Alarm Source | Distance feet (m) | Fire Source | Distance feet (m) | Average Response Time (seconds) |
|--|-------------------|----------------------|-------------------|---------------------------------|
| Sunlight, direct, reflected, modulated & unmodulated | — | 2 inch dia Heptane | 10 (3) | < 15 |
| 70 w sodium vapor lamp, unmodulated | 3 (0.9) | 1 x 1 foot n-Heptane | 40 (12) | 5 |
| 70 w sodium vapor lamp, modulated | 3 (0.9) | 1 x 1 foot n-Heptane | 40 (12) | < 1 |
| 250 w vapor lamp, unmodulated | 3 (0.9) | 1 x 1 foot n-Heptane | 40 (12) | 11 |
| 250 w vapor lamp, modulated | 3 (0.9) | 1 x 1 foot n-Heptane | 40 (12) | < 1 |
| 300 w incandescent lamp, unmodulated | 3 (0.9) | 1 x 1 foot n-Heptane | 40 (12) | 7 |
| 300 w incandescent lamp, modulated | 3 (0.9) | 1 x 1 foot n-Heptane | 40 (12) | 6 |
| 500 w halogen lamp, unmodulated | 3 (0.9) | 1 x 1 foot n-Heptane | 40 (12) | < 1 |
| 500 w halogen lamp, modulated | 3 (0.9) | 1 x 1 foot n-Heptane | 40 (12) | 11 |
| 1500 w electric radiant heater, unmodulated | 10 (3) | 1 x 1 foot n-Heptane | 40 (12) | < 1 |
| 1500 w electric radiant heater, modulated | 10 (3) | 1 x 1 foot n-Heptane | 40 (12) | < 1 |
| 2-34 w fluorescent lamps, unmodulated | 3 (0.9) | 1 x 1 foot n-Heptane | 40 (12) | 15 |
| 2-34 w fluorescent lamps, modulated | 3 (0.9) | 1 x 1 foot n-Heptane | 40 (12) | < 1 |

X5200M FALSE ALARM IMMUNITY

High Sensitivity UV & IR, Arc Off, TDSA On, Quick Fire On

| False Alarm Source | Distance feet (m) | Modulated Response | Unmodulated Response |
|--------------------------------|-------------------|--------------------|----------------------|
| Sunlight, direct, reflected | — | No alarm | No alarm |
| Arc welding | 15 (4.6) | No alarm | No alarm |
| 70 w sodium vapor lamp | 3 (0.9) | No alarm | No alarm |
| 250 w vapor lamp | 3 (0.9) | No alarm | No alarm |
| 300 w incandescent lamp | 3 (0.9) | No alarm | No alarm |
| 500 w halogen lamp | 3 (0.9) | No alarm | No alarm |
| 1500 w electric radiant heater | 3 (0.9) | No alarm | No alarm |
| 2-34 w fluorescent lamps | 3 (0.9) | No alarm | No alarm |

X5200M FIELD OF VIEW

High Sensitivity UV & IR, Arc Off, TDSA On, Quick Fire On

| Fuel | Size | Distance feet (m) | Horizontal (degrees) | Average Horz. Response Time (seconds) | Vertical (degrees) | Average Horz. Response Time (seconds) |
|--------------|----------|-------------------|----------------------|---------------------------------------|--------------------|---------------------------------------|
| Black Powder | 40 grams | 5 (1.5) | +45 | 0.1 | +45 | 0.1 |
| | | | -45 | 0.1 | -30 | 0.1 |

APPENDIX B

CSA APPROVAL

DIVISION CLASSIFICATION:

Ultraviolet Infrared Flame Detector/Controller X5200 series, rated 18-30 Vdc, 2.8 Watts to 17.5 Watts.
Relay contacts rated 5 Amps @ 30 Vdc.

CLASS 4818 04 - SIGNAL APPLIANCES - Systems - For Hazardous Locations

Class I, Division 1, Groups B, C, and D (T5); Class II, Division 1, Groups E, F, and G (T5);
Class I, Division 2, Groups A, B, C, and D (T3); Class II, Division 2, Groups F and G (T3);
Class III; Enclosure NEMA/Type 4X;

APPLICABLE REQUIREMENTS

- CAN/CSA-C22.2 No. 0-M91 – General requirements - Canadian Electrical Code, Part II
- CAN/CSA-C22.2 No. 25-1966 – Enclosures for use in Class II Groups E, F & G Hazardous Locations.
- CAN/CSA-C22.2 No. 30-M1986 – Explosion-Proof Enclosures for Use in Class I Hazardous Locations.
- CAN/CSA C22.2 No. 94-M91 – Special Purpose Enclosures.
- CAN/CSA-C22.2 No. 142-M1987 – Process Control Equipment.
- CAN/CSA-C22.2 No. 213-M1987 – Nonincendive Electrical Equipment for Use in Class I, Division 2 Hazardous Locations.

ZONE CLASSIFICATION:

CLASS 4818 04 - SIGNAL APPLIANCES - Systems - For Hazardous Locations

Ex db eb IIC T6...T5

T6 (Tamb = -50°C to +60°C)

T5 (Tamb = -50°C to +75°C)

Ex tb IIIC T95°C

(Tamb = -50°C to +75°C)

Seal required adjacent to enclosure

IP66/IP67

Ex db IIC T6...T5

T6 (Tamb = -55°C to +60°C)

T5 (Tamb = -55°C to +75°C)

Ex tb IIIC T95°C

(Tamb = -55°C to +75°C)

Seal required adjacent to enclosure

IP66/IP67

APPLICABLE REQUIREMENTS

- CAN/CSA-C22.2 No. 60079-0: 2007 – Electrical apparatus for explosive atmospheres. Part 0: General requirements
- CAN/CSA-C22.2 No. 60079-1: 2011 – Explosive atmospheres. Part 1: Equipment protection by flameproof enclosures "d"
- CAN/CSA-C22.2 No. 60079-7: 2012 – Explosive atmospheres. Part 7: Equipment protection by increased safety "e"
- CAN/CSA-C22.2 No. 60079-31: 2012 – Explosive atmospheres. Part 31: Equipment dust ignition protection by enclosure "t"

The following accessories are CSA approved for use with the X5200, X5200G, and X5200M Flame Detectors:

| Part Number | Description |
|-------------|--|
| 102740-002 | Magnet |
| 007739-001 | Magnet and Extension Pole |
| 007290-001 | Q9033B Stainless Steel Mounting Arm Assembly is for aluminum and stainless steel detectors |
| 007290-002 | Q9033A Aluminum Mounting Arm Assembly is for aluminum detectors only |
| 011385-001 | Q9033 Collar Attachment |

APPENDIX C

ATEX APPROVAL

EC-TYPE EXAMINATION CERTIFICATE

DEMKO 02 ATEX 132195X

Increased Safety Model

CE 0539  II 2 G
II 2 D

Ex db eb IIC T6...T5 Gb

Ex tb IIIC T85°C Db

T6 (Tamb = -50°C to +60°C)

T5 (Tamb = -50°C to +75°C)

IP66/IP67.

Flameproof Model

CE 0539  II 2 G
II 2 D

Ex db IIC T6...T5 Gb

Ex tb IIIC T85°C Db

T6 (Tamb = -55°C to +60°C)

T5 (Tamb = -55°C to +75°C)

IP66/IP67.

Compliance with:

EN 60079-0: 2018

EN 60079-1: 2014

EN 60079-7: 2015+A1:2018

EN 60079-31: 2014

EN 60529:1991+A1:2000+A2:2013

INSTALLATION INSTRUCTIONS

The field wiring connections in the terminal compartment are ATEX certified and accepts wiring specifications from 14-24 AWG or 2.5-0.2 mm².

The flame detector shall be installed according to the instructions given by the manufacturer.

The cable entry devices shall be certified in type of explosion protection flameproof enclosure "d" for use with the terminal compartment in type of explosion protection flameproof enclosure "d", or in type of explosion protection increased safety "e" for use with the terminal compartment in type of explosion protection increased safety "e". They shall be IP66/IP67 rated, suitable for the conditions of use and correctly installed.

Unused entries shall be closed with suitable certified blanking elements.

The metal housing for the Ultraviolet Infrared (UVIR) flame detector must be electrically connected to earth ground.

For ambient temperatures below -10°C and above +60°C use field wiring suitable for both minimum and maximum ambient temperature.

Special conditions for safe use:

- Up to two resistors may be used within the flameproof terminal compartment only.
- The total maximum power dissipation of the resistor(s) shall not exceed 5 watts and each resistor must be rated appropriately for the application.
- The Ultraviolet Infrared (UVIR) flame detector is to be installed in places where there is a low risk of mechanical damage.
- See the "Maintenance" section of this manual for guidance on minimizing the risk from electrostatic discharge.
- Flameproof joints are not intended to be repaired. See the "Device Repair and Return" section of this manual for more information on conducting repairs.

APPENDIX D

IECEX APPROVAL

CERTIFICATE OF CONFORMITY

IECEX ULD 06.0018X

| | | |
|----------------------------|----|----------------------------|
| Ex db eb IIC T6...T5 Gb | | Ex db IIC T6...T5 Gb |
| Ex tb IIIC T85°C Db | | Ex tb IIIC T85°C Db |
| T6 (Tamb = -50°C to +60°C) | or | T6 (Tamb = -55°C to +60°C) |
| T5 (Tamb = -50°C to +75°C) | | T5 (Tamb = -55°C to +75°C) |
| IP66/IP67. | | IP66/IP67. |

Compliance with:

IEC 60079-0: 2017, Ed. 7
IEC 60079-1: 2014, Ed. 7
IEC 60079-7: 2017, Ed. 5.1
IEC 60079-31: 2013, Ed. 2
IEC 60529: 2013, Ed. 2.2

INSTALLATION INSTRUCTIONS

The field wiring connections in the terminal compartment are suitable certified and accepts wiring specifications from 14-24 AWG or 2.5-0.2 mm².

The flame detector shall be installed according to the instructions given by the manufacturer.

The cable entry devices shall be certified in type of explosion protection flameproof enclosure "d" for use with the terminal compartment in type of explosion protection flameproof enclosure "d," or in type of explosion protection increased safety "e" for use with the terminal compartment in type of explosion protection increased safety "e." They shall be IP66/IP67 rated, suitable for the conditions of use and correctly installed.

Unused entries shall be closed with suitable certified blanking elements.

The metal housing for the Ultraviolet Infrared (UVIR) flame detector must be electrically connected to earth ground.

For ambient temperatures below -10°C and above +60°C use field wiring suitable for both minimum and maximum ambient temperature.

Special conditions for safe use:

- Up to two resistors may be used within the flameproof terminal compartment only.
- The total maximum power dissipation of the resistor(s) shall not exceed 5 watts and each resistor must be rated appropriately for the application.
- The Ultraviolet Infrared (UVIR) flame detector is to be installed in places where there is a low risk of mechanical damage.
- See the "Maintenance" section of this manual for guidance on minimizing the risk from electrostatic discharge.
- Flameproof joints are not intended to be repaired. See the "Device Repair and Return" section of this manual for more information on conducting repairs.

APPENDIX E

EN54 APPROVALS

APPLICABLE TO MODEL X5200

| Certification Bodies | Conventional Output | | LON Output | |
|---------------------------------------|-----------------------------|---------------------------------------|-----------------------------|---------------------------|
| | Certificate/Approval Number | Basis of Approval | Certificate/Approval Number | Basis of Approval |
| VdS – Construction Product Regulation | — | — | — | — |
| VdS | G 203085 | VdS 2344 VdS 2504 EN 54-10 + A1 | — | — |
| BRE – Construction Product Regulation | 2831 – CPR- F1838 | EN 54-10 + A1 | 2831 – CPR – F1839 | EN 54-10 + A1 EN 54-17 |
| LPCB | 973e/02 | EN 54-10 + A1 | 973a/02 | EN 54-10 + A1 EN 54-17 |

APPLICABLE TO MODEL X5200G

| Certification Bodies | Conventional Output | | LON Output | |
|---------------------------------------|-----------------------------|---------------------------------------|-----------------------------|---------------------------|
| | Certificate/Approval Number | Basis of Approval | Certificate/Approval Number | Basis of Approval |
| VdS – Construction Product Regulation | — | — | — | — |
| VdS | G 203058 | VdS 2344 VdS 2504 EN 54-10 + A1 | — | — |
| BRE – Construction Product Regulation | 2831 – CPR- F1178 | EN 54-10 + A1 | 2831-CPR-F1685 | EN 54-10 + A1 EN 54-17 |
| LPCB | 973e/05 | EN 54-10 + A1 | 973a/05 | EN 54-10 + A1 EN 54-17 |

INSTRUCTIONS FOR THE APPLICATION OF THE APPROVAL COMPONENT/SYSTEM

The installation of the X5200 and X5200G flame detectors meet the directional dependence requirements of EN 54-10, Clause 5.4 for any β angle when the α angle does not exceed $\pm 30^\circ$ (total field of view = 60°).

A maximum achievable horizontal α angle of $\pm 45^\circ$ (total Horizontal field of view = 90°) was obtainable with a β angle of 0° (unit mounted in the upright position).

The X5200 and X5200G flame detectors are EN 54-10 approved for any combination of the following settings described for each Class:

| Setting | Class 1 (25 m) | Class 2 (17 m) | Class 3 (12 m) |
|----------------|---------------------------------|---------------------------------|---------------------------------|
| UV Sensitivity | High or Very High | Medium, High, or Very High | Low, Medium, High, or Very High |
| IR Sensitivity | High or Very High | Medium, High, or Very High | Low, Medium, High, or Very High |
| Arc Rejection | Low, Medium, High, or Very High | Low, Medium, High, or Very High | Low, Medium, High, or Very High |
| TDSA | On | On | On |
| Quick Fire | On or Off | On or Off | On or Off |

The following accessories are EN54-10 and EN54-17 approved for use with X5200 and X5200G Flame Detectors:

| Part Number | Description |
|-------------|--|
| 102740-002 | Magnet |
| 007739-001 | Magnet and Extension Pole |
| 007290-001 | Q9033B Stainless Steel Mounting Arm Assembly is for aluminum and stainless steel detectors |
| 007290-002 | Q9033A Aluminum Mounting Arm Assembly is for aluminum detectors only |
| 011385-001 | Q9033 Collar Attachment |

APPENDIX F

ADDITIONAL APPROVALS

SIL 2



IEC 61508

Certified SIL 2 Capable.

Applies to specific models – refer to the SIL 2 Certified X5200/X5200G Safety Manual (95-8672) for details.

RUSSIA & KAZAKHSTAN



VNIIFTRI

CERTIFICATE OF CONFORMITY TO TP TC 012/2011

TC RU C-US. BH02.B.00234

2ExdIICT6/T5 IP66

T6 (Tamb = -55°C to +60°C)

T5 (Tamb = -55°C to +75°C)

- OR -

1ExdIICT6/T5IP66

T6 (Tamb = -55°C to +60°C)

T5 (Tamb = -55°C to +75°C)

RUSSIA



VNIIPO

CERTIFICATE OF CONFORMITY TO TECHNICAL REGULATIONS, GOST R 53325-2012

C-US.ПБ01.B.02841

BRAZIL



UL-BR 17.0216X

Ex db eb IIC T6...T5 Gb

Ex tb IIIC T85°C Db

T6 (Tamb -50°C TO +60°C)

T5 (Tamb -50°C TO +75°C)

IP66/IP67

- OR -

Ex db IIC T6...T5 Gb

Ex tb IIIC T85°C Db

T6 (Tamb -55°C TO +60°C)

T5 (Tamb -55°C TO +75°C)

IP66/IP67

FRANCE



AFNOR Identification No: LIR 010 A0.

For specific information regarding the X5200G Flame Detector's conformity to NF EN54-10, reference Addendum number 95-8699.

APPENDIX G

DECLARATION OF CONFORMITY



EU Declaration of Conformity

Model X5200 Series (Ultraviolet/Infrared Flame Detector)

The object of the declaration described above is in conformity with the relevant Union harmonisation legislation:

ATEX Directive: 2014/34/EU

Certificate No.: DEMKO 01 ATEX 132195X

EN 60079-0:2018

Issued by: DEMKO

EN 60079-1:2014



II 2 G Ex db IIC T6...T5 Gb IP66/IP67

EN 60079-7:2015+A1:2018

EN 60079-31:2014



II 2 G Ex db eb IIC T6...T5 Gb IP66/IP67



II 2 D Ex tb IIIC T85°C Db IP66/IP67

QAN by:

UL International DEMKO A/S, NB. No. 0539

Borupvang 5A, 2750 Ballerup, Denmark

EMC Directive: 2014/30/EU

EN 61000-6-2:2005

EN 61000-6-4:2007

EN 50130-4:2011

RoHS Directive: 2011/65/EU

EN 50581:2012

Radiological protection – Sealed radioactive sources
(not applicable to X5200G)

ISO 2919:2012

This declaration of conformity is issued under the sole responsibility of the manufacturer

Signature:

2020-08-20

Mike Farrell

Approvals Manager

Manufactured by:

Detector Electronics Corporation
6901 West 110th Street | Minneapolis, MN 55348 USA
Phone: +1 (1) 952-946-6488
www.det-tronics.com



95-8546



FlexSonic® Acoustic
Leak Detector



X3301 Multispectrum
IR Flame Detector



PointWatch Eclipse® IR
Combustible Gas Detector



FlexVu® Universal Display
with GT3000 Toxic Gas Detector



Eagle Quantum Premier®
Safety System

Specifications subject to change without notice.

All trademarks are the property of their respective owners.

© 2020 Detector Electronics Corporation. All rights reserved.



Corporate Office
6901 West 110th Street
Minneapolis, MN 55438 USA
www.det-tronics.com

Phone: +1 952.941.6665
Toll-free: +1 800.765.3473
Fax: 952.829.8750
det-tronics@carrier.com