

## Electrochemical H<sub>2</sub>S Detector Model C7064E



### APPLICATION

The C7064E Electrochemical H<sub>2</sub>S Detector provides reliable detection and measurement of hydrogen sulfide (H<sub>2</sub>S) gas concentrations in hazardous industrial areas. The detector is designed for use with Det-Tronics FlexVu® UD10 Universal Display Unit, Model U9500B Transmitter, R8471B Controller, or other devices capable of monitoring a 4 to 20 mA dc input. The C7064E is FM Approved and CSA Certified for use in hazardous environments.

### FEATURES

- Reliable electrochemical sensor delivers excellent accuracy, specificity, and is performance-approved.
- Robust stainless steel housing is certified explosion-proof and EMI/RFI hardened.
- Temperature compensated to ensure consistent performance over operating temperature range.
- Hydrophobic filter provides exceptional sensor protection.
- Easily replaced electrochemical sensor cell.
- Easy two-wire installation can be used with or without a display transmitter.

## DESCRIPTION

The C7064E detector consists of an explosion-proof stainless steel enclosure, which houses the electrochemical sensor and the transmitter circuitry. The detector provides a loop-powered 4 to 20 mA output signal that is proportional to the full scale range of the electrochemical sensor installed in the detector. Three (3) electrochemical sensors providing 20, 50, and 100 PPM ranges are offered. The user must ensure that the 4-20 mA signal receiver is properly scaled to match the full scale range of the sensor installed within the C7064E. The C7064E provides three (3) wires for user termination: Signal (+), Signal (-), and earth ground.

## ELECTROCHEMICAL SENSOR

The electrochemical sensor uses capillary diffusion barrier technology for detecting the presence of hydrogen sulfide gas. The sensor provides improved accuracy, reliability, and extended calibration intervals when compared to ordinary solid state type sensors.

The response of the sensor is highly specific to H<sub>2</sub>S. Most commonly encountered gases have little if any cross sensitivity effect. Table 1 shows the response of a typical electrochemical H<sub>2</sub>S sensor (0 to 100 ppm range) when exposed to 100 ppm concentrations of various commonly encountered substances.

## Sensor Output

The 4 to 20 mA dc drive circuitry is rated at a maximum 600 ohms loop resistance with 24 Vdc supply voltage.

Table 1—Cross Sensitivity of Electrochemical Sensor to 100 ppm Concentrations

0 ppm	<1 ppm	<20 ppm	<10 ppm	-20 ppm
HCN	NO	SO <sub>2</sub>	CO	Cl <sub>2</sub>
C <sub>2</sub> H <sub>4</sub>	HCl		H <sub>2</sub>	NO <sub>2</sub>

NOTE: Values shown are for a typical 0 to 100 ppm sensor. Response of 0 to 20 ppm and 0 to 50 ppm sensor will be proportionately lower.

## OPTIONAL TRANSMITTERS, CONTROLLER AND CALIBRATOR

The C7064E detector's 4 to 20 mA output is calibrated at the factory, but requires an additional transmitter or controller to perform calibration in the field. For applications where a local display of detected H<sub>2</sub>S gas level is required, the FlexVu® Model UD10 Universal Display Unit or the Model U9500B200x Infinity Transmitter is recommended for use with the C7064E. For applications where a control/display card in a mounting rack is required, the Model R8471B Series H<sub>2</sub>S controller is recommended for use with the C7064E.

## HYDROPHOBIC FILTER

The C7064E uses a hydrophobic filter to protect the electrochemical sensor from contamination by dirt and moisture. The hydrophobic filter can be replaced quickly and conveniently in the field if damaged or fouled. Removal of the filter is not necessary to perform calibration.

## SPECIFICATIONS

### GAS MEASUREMENT RANGE—

0 to 20, 50, or 100 ppm H<sub>2</sub>S depending upon the 005434-xxx electrochemical sensor specified.

### OUTPUT SIGNAL—

Two-wire, loop-powered 4 to 20 mA analog signal at 600 ohms maximum resistance with 24 Vdc applied.

### POWER CONSUMPTION RANGE—

0.25 to 0.8 watts maximum.

### VOLTAGE REQUIREMENTS—

12-32 Vdc, 24 Vdc recommended.

### MAXIMUM LOOP RESISTANCE—

300 ohms @ 18 Vdc, 600 ohms @ 24 Vdc, 1000 ohms @ 32 Vdc.

### TEMPERATURE RANGE—

Operating: -40°F to +122°F (-40°C to +50°C).  
Storage: +32°F to +68°F (0°C to +20°C).

### NOTE

*The C7064E has successfully completed Hazardous Location testing from -40°C to +75°C; however, the label will indicate -40°C to +50°C.*

### HUMIDITY RANGE—

Operating: 15 to 90% RH, non-condensing.  
Storage: 15 to 90% RH, non-condensing.

### ACCURACY—

±10 percent of applied gas concentration or ±3 ppm, whichever is greater.

### RESPONSE TIME—

T20 in ≤ 12 seconds,  
T50 in ≤ 30 seconds,  
T90 in ≤ 60 seconds.

### STABILITY—

Zero: < 1 PPM / month,  
Span: < 1 % FS / month.

## CERTIFICATION—

FM: Model C7064E5014:  
Class I, Div. 1, Groups B, C & D.

Model C7064E4012 and C7064E5012:  
Class I, Div. 1, Groups C & D.

CSA: Model C7064E5014:  
Class I, Div. 1, Groups B, C & D;  
Class I, Div. 2, Groups A, B, C & D (T4A).

C7064E Series:  
Class I, Div. 1, Groups C & D;  
Class I, Div. 2, Groups A, B, C & D (T4A).

IEC: Ex d IIB +H2 T4.  
SIRA Ex 02Y1010X.  
T<sub>amb</sub>: -40°C to +75°C.  
IP54.

## WARNING

*Ensure that the sensor hazardous (classified) location rating is applicable for the intended use.*

## ENCLOSURE MATERIAL—

316 stainless steel.

## DIMENSIONS—

See Figure 1.

## SHIPPING WEIGHT (APPROXIMATE)—

Detector housing: 2.5 pounds (1.1 kilograms),  
Sensor: 0.2 pound (0.1 kilogram).

## WARRANTY—

Two years from date of manufacture. Typical service life is 3-5 years depending upon ambient environmental conditions.

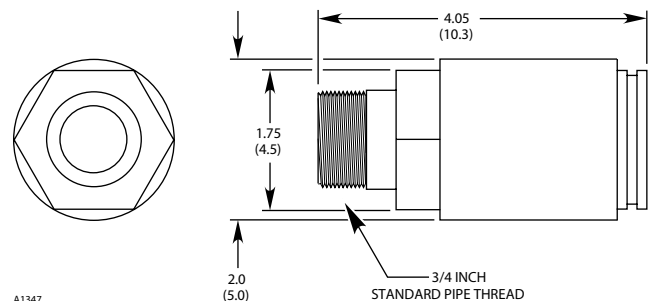

Figure 1—Sensor Dimensions in Inches (Centimeters)

## INSTALLATION

### CAUTION

*The electrochemical sensor contains semiconductor devices that are sensitive to electrostatic discharge. Damage caused by electrostatic discharge can be virtually eliminated if the equipment is handled only in a static safeguarded work area and if it is transported in a package that will provide the necessary protection against static electricity (such as the original factory packaging). Since a static safeguarded work area is usually impractical in most field installations, handle the device by the housing, taking care not to touch electronic components or terminals.*

### DETECTOR POSITIONING

Proper detector location is essential for providing maximum protection. The most effective number and placement of detectors varies depending on the conditions at the job site. The individual designing the system must rely on experience and common sense to determine the number of detectors needed and the best locations to adequately protect the area. The following factors are important and should be considered for every installation:

1. Since hydrogen sulfide is a highly toxic gas, a primary consideration in determining optimum detector locations is to identify where people are most likely to first come into contact with the toxic gas. This contact point is typically a prime location for an H<sub>2</sub>S gas detector.
2. Factors such as vapor density should also be considered when determining detector locations. Hydrogen sulfide is slightly heavier than clean air, and therefore may tend to settle near the floor or ground, unless it is heated, mixed with other gases that are lighter than air, or prevented from doing so by ambient air movement patterns.
3. How rapidly will the H<sub>2</sub>S gas diffuse into the air? Select a location for the detector as close as practical to an anticipated source.
4. Ventilation characteristics of the immediate area must also be considered. Air movement may cause the gas to accumulate more heavily in one area than another. Detectors should be placed where the most concentrated accumulation of hydrogen sulfide gas is anticipated. Also consider the fact that some ventilation systems do not operate continuously, and therefore areas with poor circulation should be evaluated for toxic gas accumulation.

5. The detector should be located where it is safe from potential sources of contamination.
6. To prevent the buildup of contaminants on the filter, the detector should never be installed with the opening pointed straight up.
7. The detector must be accessible for testing and calibration.
8. Exposure to excessive heat or vibration can cause premature failure of electronic devices, and should be avoided if possible. Shielding the device from intense sunlight will reduce solar heating and can increase the life of the unit.

### WIRING REQUIREMENTS

Two or three wire, shielded cable is recommended for connecting the C7064E detector to a transmitter, controller or other analog input device. Note that the third conductor from the C7064E is an earth ground conductor that is normally terminated at the junction box earth ground lug. The use of shielded cable will help protect against interference caused by extraneous electrical "noise." In applications where the detector cable is installed in conduit, the conduit should not be used for wiring to other electrical equipment whenever possible. If other equipment power wiring is run in the same conduit, the detector cabling **must** be shielded. The maximum allowable distance between the detector and signal receiver is limited by the resistance of the cabling used. Table 2 shows the maximum cabling distance allowed for a given wire size with 24 Vdc supplied. If an additional signal conditioning or relay output transmitter is being used along with the C7064E detector, refer to the specific transmitter manual for detailed wiring instructions.

Table 2—Maximum Wiring Distances-  
C7064E Detector to Controller/Transmitter

Wire Size (AWG)	Maximum Distance C7064E Detector to Controller	
	Feet	Meters
18	5700	1750
16	9000	2800

## DETECTOR INSTALLATION AND WIRING

1. Determine the best mounting locations for the detectors. Whenever possible, mount the detector with the filter pointing down to minimize exposure to contamination.
2. The C7064 detector junction box (or housing of associated transmitter) is intended for flat-surface mounting, such as on a wall or post. A junction box spacer or stand-off (1/4 to 1/2 inch) may be needed to allow adequate clearance for the detector and calibration cup. The junction box should be electrically connected to earth ground.

### NOTE

Coat the junction box cover and detector threads with an appropriate grease to ease installation and future removal. The recommended lubricant is a silicone free grease, part number 005003-001, available from Detector Electronics.

### NOTE

The 005434-xxx electrochemical H<sub>2</sub>S sensor does not need to be installed within the C7064E housing while installing and wiring the detector/junction box. It is recommended to keep the sensor within the manufacturer's sealed shipping bag in a cool storage environment until actual power-up and calibration commissioning is performed. This will ensure that the sensor will provide maximum longevity.

### NOTE

Some C7064E models are furnished with the red and black wires connected to a four-position plug. When wiring the C7064E to a transmitter or junction box using screw terminals, cut off the plug and strip the wires back approximately 1/4 inch (6 cm).

3. Install the C7064 detector within the proper opening in the junction box. Terminate all three (3) C7064 conductors at the proper terminals. Refer to the appropriate illustration for details:

Figure 2 — Typical C7064E stand-alone detector.

Figures 3 & 4 — C7064E wired to UD10 Display Unit.

Figures 5 & 6 — C7064E wired to U9500 Infinity Transmitter.

Figure 7 — C7064E wired to R8471B Controller.

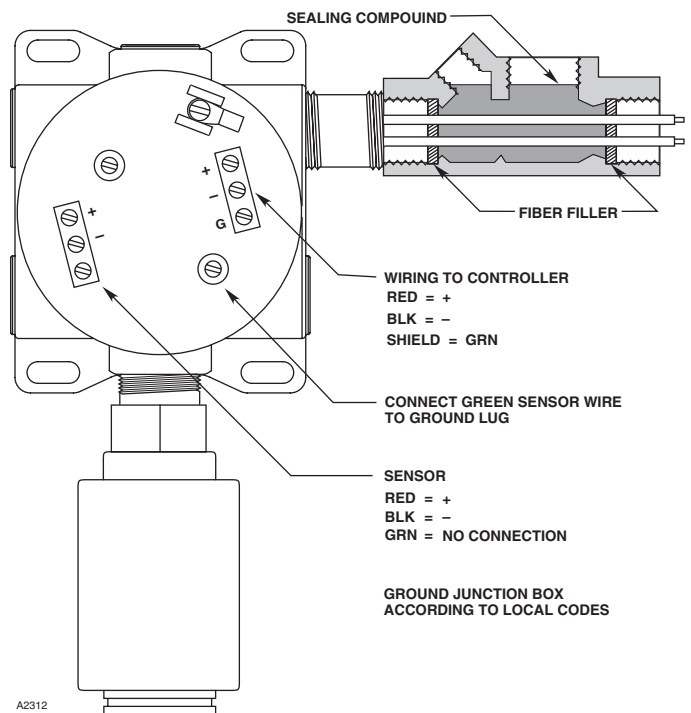

Figure 2—A Typical C7064E Stand-Along Detector

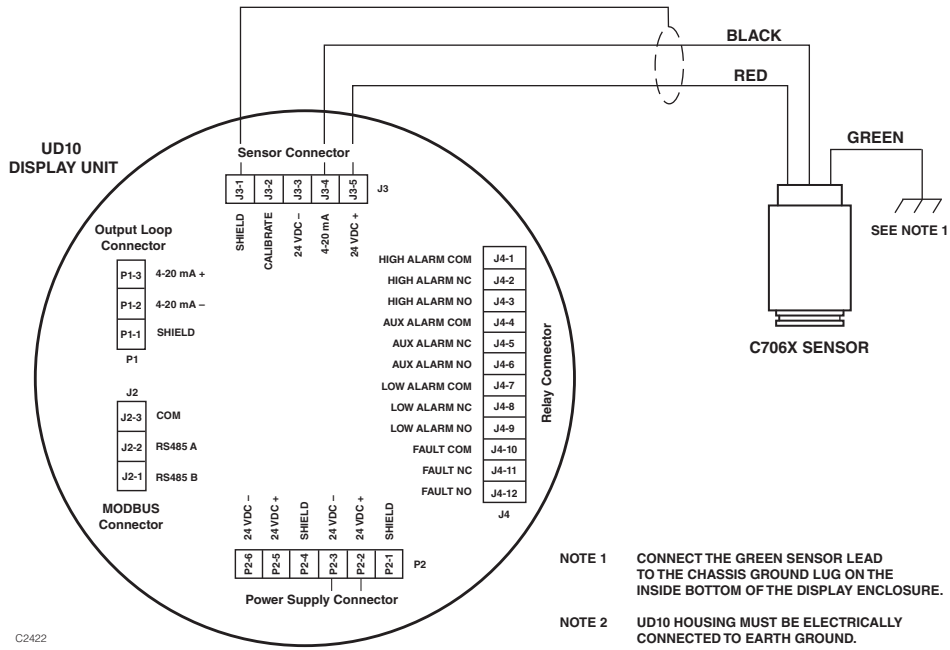

Figure 3—C7064E Sensor Wired Directly to a UD10 Universal Display Unit

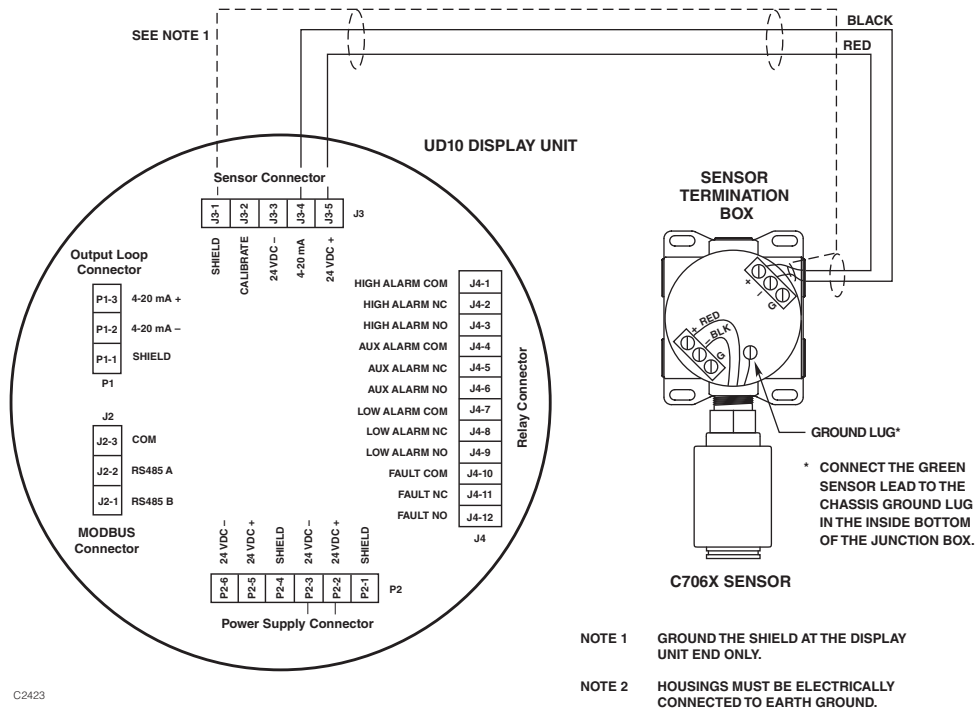
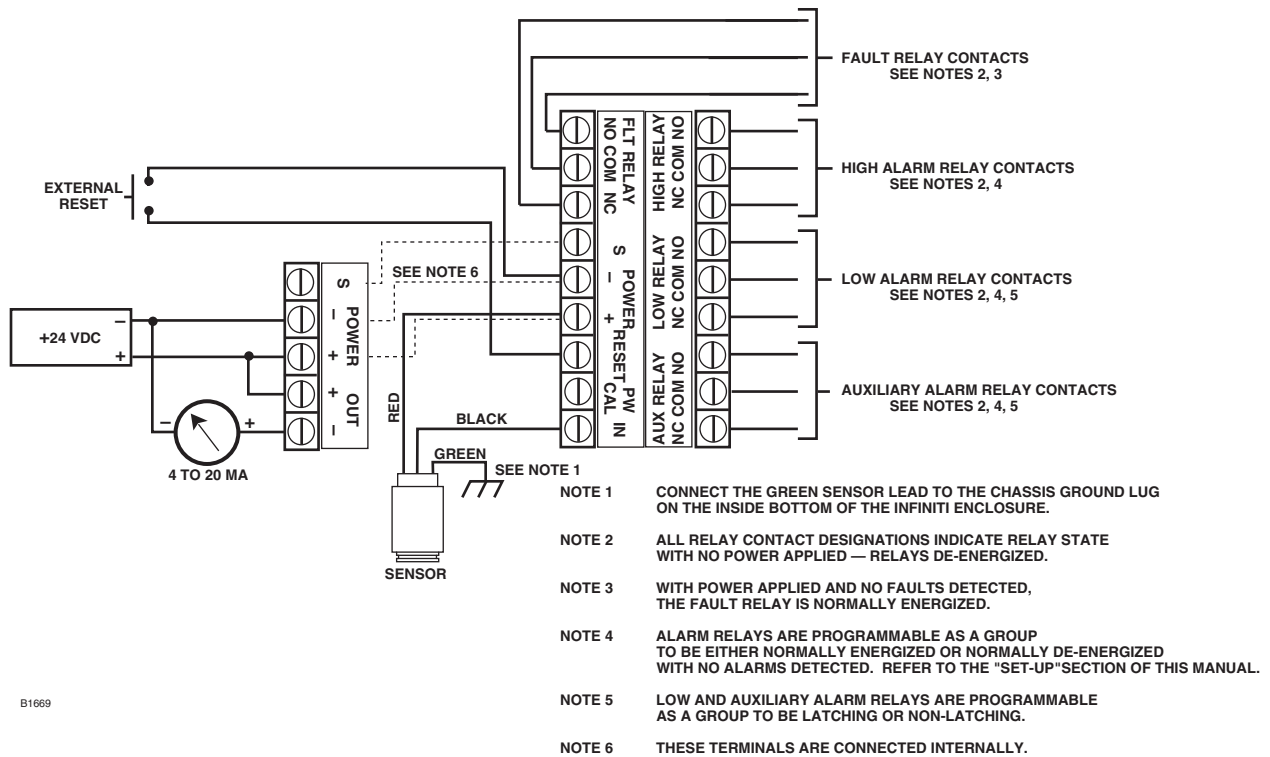

Figure 4—C7064E Sensor Wired to a UD10 Universal Display Unit through STB Termination Box



B1669

Figure 5—C7064E Detector Directly Wired to a U9500 Infiniti Transmitter

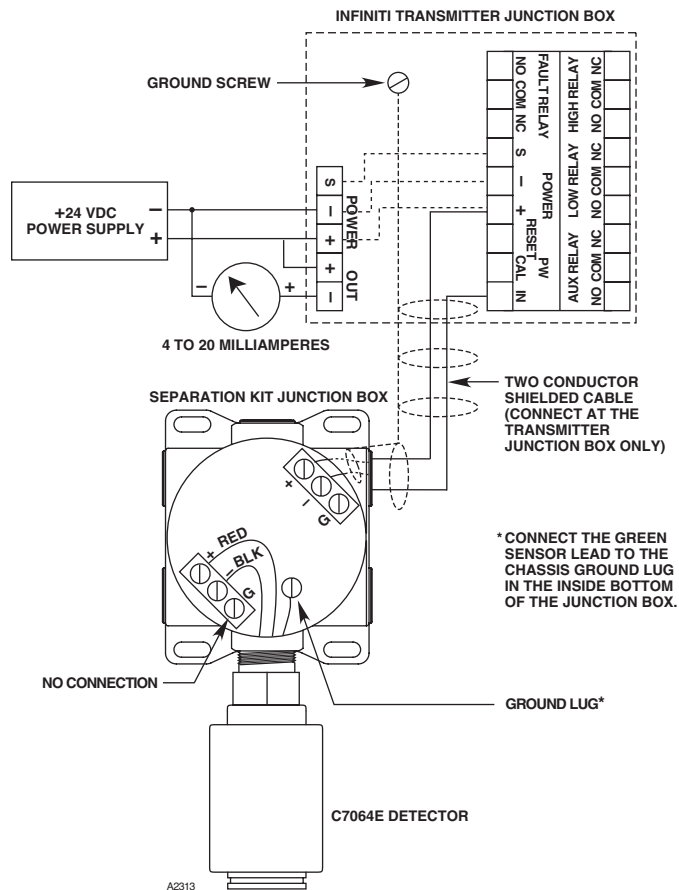

Figure 6—C7064E Detector Wired to a U9500 Infiniti Transmitter Using a Separation Kit Junction Box

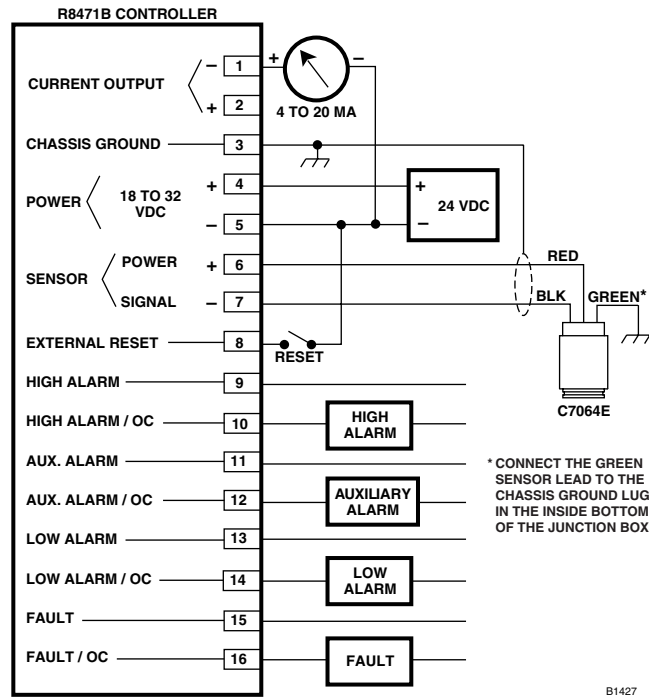

Figure 7—C7064E Detector Wired to an R8471B Controller

4. Confirm that the power and signal cabling for the detector is the proper size and type, and is appropriate for the application requirements. After all electrical connections are made, double check the terminations against the wiring diagrams to ensure that all connections are properly terminated.
5. The C7064E is designed to operate with an input voltage from 12 to 32 Vdc. Before proceeding with complete system commissioning, measure the delivered voltage at the C7064E detector to ensure that possible voltage drops have not compromised the necessary supply voltage.

**NOTE**

*Do not apply power to the system with the junction box cover removed unless the area has been de-classified.*

6. After confirming that all connections are properly terminated and other installation requirements such as conduit seals are installed as required, the sensor may be installed within the C7064E detector. Begin by removing the cap from the detector housing. Refer to Figure 8.

7. Remove the sensor assembly from its packaging. Determine proper orientation for the assembly, then **carefully** plug it into the detector housing.

**NOTE**

*Handle the sensor assembly carefully. To avoid possible damage, observe the normally accepted procedures for handling electrostatic sensitive devices.*

8. Replace the cap back on the detector housing. Ensure that the cap O-ring is present and in good condition. Tighten the cap only until snug. **Do not over tighten.**
9. After confirming that the sensor is installed within the detector housing, all electrical terminations are properly made, proper operating voltage is provided to the detector, and all field cabling is appropriate for the application requirements, the installer may conduct the startup procedure.



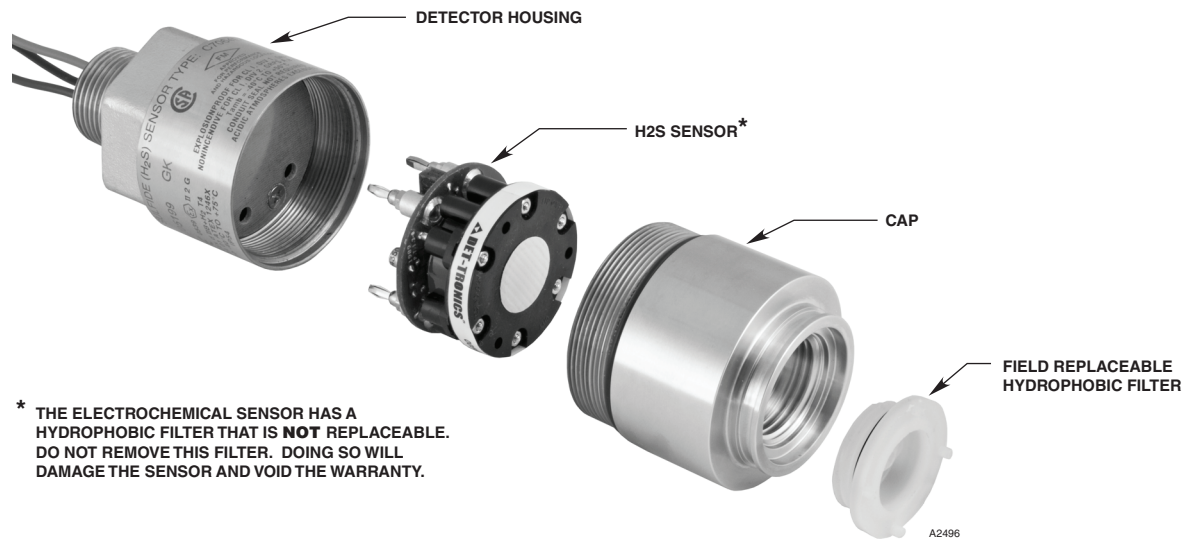

Figure 8—C7064E Detector

## STARTUP PROCEDURE

1. Ensure that any output loads actuated by the detection system are bypassed to prevent accidental or unnecessary activation of these devices if required.
2. Apply power to the system. If the C7064E is used in a stand-alone configuration, verify that a nominal 4 mA output signal is generated by the detector. If the C7064E is used with the U9500B Infronti, verify that both "warm-up" and "toxic" messages are displayed on the LCD readout, and that after warmup is complete, a nominal 0 ppm indication is displayed. If the C7064E is used with a UD10, ensure that the appropriate operating mode is selected by following the procedure described in the Startup section of the UD10 manual.
3. Allow the detector to operate for about 24 hours prior to an initial calibration, then perform the "Calibration Procedure" as described in the following section. It may be necessary to refer to other transmitter and/or controller manuals to complete C7064E detector calibration.
4. Complete any additional startup/commissioning requirements as described in the controller/transmitter manual if utilized.
5. Place the system in normal operation.

## CALIBRATION

### FREQUENCY OF CALIBRATION

The C7064E detector is typically utilized to protect human life. For this reason, a frequent calibration inspection is recommended. The specific frequency required in different applications can vary depending upon the amount of background gas, concentration of exposed H<sub>2</sub>S, and ambient environmental conditions.

Calibration **must** be performed:

- When a new system is initially put into service.
- When the electrochemical sensor or C7064E detector housing is replaced.
- If a transmitter, controller or other device used in conjunction with the C7064E detector is replaced.
- When the hydrophobic filter is cleaned or replaced.

The following calibration schedule is recommended when placing a new sensor into operation and will ensure reliable operation in most applications:

1. 24 hours after initial power-up
2. One week later
3. Every 30 days thereafter, or as determined by the needs of the specific application.

### **IMPORTANT**

*To ensure adequate protection, the H<sub>2</sub>S detection system must be calibrated on a regularly scheduled basis.*

## CALIBRATION GAS

The detector must be calibrated using hydrogen sulfide mixed with either air or nitrogen. For best results, calibration should be performed using a calibration gas concentration equal to mid-point of the electrochemical sensor's specific measurement range. This is typically either 50, 25, or 10 ppm H<sub>2</sub>S concentrations, and all are available within a complete H<sub>2</sub>S calibration kit available from Detector Electronics. Each kit provides the proper compressed gas, 1 LPM regulator, hose, and special calibration cup for the C7064E detector.

If background H<sub>2</sub>S gas is present, it may be necessary to purge the detector with clean air to ensure that an accurate zero or "clean air" condition is present prior to initiating calibration.

### CALIBRATION PROCEDURE

The C7064E detector requires a two-step calibration process similar to other two-wire gas detectors, but does not provide field access to the on-board zero or span potentiometers. Therefore, it is highly recommended that a Model UD10 Universal Display Unit, Model U9500B Transmitter, or Model R8471B Controller be utilized with the C7064E to enable non-intrusive field calibration. (Refer to the UD10, U9500B or R8471B instruction manual for calibration information.)

Some control systems provide calibration capability by allowing the system alarm output threshold levels to be adjusted up or down as necessary to match C7064E span output level deviation (if present) from optimum condition (typically 12 mA detector output level is generated in response to 50% full scale calibration gas exposure). While this method does not actually adjust detector zero or span levels, it ensures that the output actions occur at a verified gas concentration condition.

## MAINTENANCE

The C7064E detector is an industrial-grade device suitable for a wide variety of challenging environmental conditions. However, a routine maintenance schedule is recommended to ensure that the detector is in peak operating condition at all times. To ensure top performance, service the device as follows.

### VISUAL INSPECTION

A visual inspection of the detector approximately once per week is recommended to ensure that physical obstructions such as trash, debris, mud, snow, or oil have not blocked or impeded hazardous gas access to the sensor. This includes visually inspecting the hydrophobic filter on the detector nosepiece.

### RESPONSE TEST

It is acceptable to perform a detector response verification test in lieu of a complete calibration if the detector output in clean air appears stable and the device has been calibrated recently. This test involves simply applying calibration gas to the detector while in normal operating mode and confirming that the detector output is proportional to the applied gas concentration. It is the operator's responsibility to bypass any and all system alarm output devices, if necessary, prior to conducting the detector response test. If the response test results are not acceptable, then a complete calibration must be performed.

### CALIBRATION

As mentioned earlier, the recommended Calibration frequency for the C7064E is as follows:

- 24 hours after initial power-up
- One week later
- Every 30 days thereafter, or as determined by the needs of the specific application.

## HYDROPHOBIC FILTER

A dirty filter can significantly reduce the amount of H<sub>2</sub>S gas that is able to reach the sensor, thereby impairing the ability of the system to respond to a hazardous condition. If the filter becomes dirty and cannot be properly cleaned or if it is damaged, it must be replaced. Do not use solvents to clean the filter. To replace the hydrophobic filter, simply unscrew the existing filter from the housing, then replace it with a new filter. Use care not to over tighten.

### NOTE

*If the detector cannot be calibrated or responds slowly to the calibration gas, check the condition of the hydrophobic filter before replacing the sensor assembly. The hydrophobic filter should be clean and squarely seated in the housing.*

## ELECTROCHEMICAL SENSOR REPLACEMENT

The electrochemical sensor is not field repairable. If calibration can no longer be properly performed, the sensor must be replaced. The area must be de-classified or power to the detector should be removed prior to replacing the sensor in a hazardous area.

To replace the sensor in the C7064E Detector:

1. Remove power from the detector.
2. Remove the cap from the detector housing. See Figure 8. (There is no need to remove the detector housing from the junction box.)
3. Remove the old sensor. Check for corrosion or contamination on the terminals inside the detector housing. Clean if necessary.
4. Determine proper orientation for the new sensor, then **carefully** plug it in.

### NOTE

*Handle the sensor carefully. To avoid possible damage, observe the normally accepted procedures for handling electrostatic sensitive devices.*

5. Place the cap back on the detector housing. Tighten only until snug. **Do not over-tighten.**
6. Re-apply power.
7. Allow time for the sensor to warm up (approximately 24 hours for best results), then calibrate.

An adequate supply of spare sensors should be kept on hand for field replacement. For maximum protection against contamination and deterioration, they should not be removed from the original protective packaging until the time of installation. To ensure maximum storage life, sensors should be stored at a temperature between 32°F and 68°F (0 to 20°C) and a relative humidity between 15 and 90 percent. Always calibrate after replacing the sensor or detector housing.

**NOTE**

*The sensor contains an acid that occasionally can leak. If leakage should occur, handle the sensor carefully to prevent any acid from contacting the skin. If acid should come in contact with the skin, wash the affected area thoroughly with soap and water. Never attempt to open the sensor.*

**DEVICE REPAIR AND RETURN**

Prior to returning devices, contact the nearest local Detector Electronics office so that a Service Order number can be assigned. A written statement describing the malfunction must accompany the returned device or component to expedite finding the cause of the failure.

Pack the unit properly. Use sufficient packing material in addition to an antistatic bag or aluminum-backed cardboard as protection from electrostatic discharge.

Return all equipment transportation prepaid to the factory in Minneapolis.

**ASSISTANCE**

For additional information or for assistance in ordering a system to fit your application, please contact:

Detector Electronics Corporation  
 6901 West 110th Street  
 Minneapolis, Minnesota 55438 USA  
 Operator: +1 (952) 941-5665 or +1 (800) 765-FIRE  
 Customer Service: +1 (952) 946-6491  
 Fax: (952) 829-8750  
 Web site: [www.det-tronics.com](http://www.det-tronics.com)  
 E-mail: [det-tronics@carrier.com](mailto:det-tronics@carrier.com)



FlexSonic® Acoustic Leak Detector



X3301 Multispectrum IR Flame Detector



PointWatch Eclipse® IR Combustible Gas Detector



FlexVu® Universal Display with GT3000 Toxic Gas Detector



Eagle Quantum Premier® Safety System

Specifications subject to change without notice.

All trademarks are the property of their respective owners. © 2020 Detector Electronics Corporation. All rights reserved.

Det-Tronics manufacturing system is certified to ISO 9001—the world's most recognized quality management standard.



**Corporate Office**  
 6901 West 110th Street  
 Minneapolis, MN 55438 USA  
[www.det-tronics.com](http://www.det-tronics.com)

Phone: +1 952.941.6665  
 Toll-free: +1 800.765.3473  
 Fax: 952.829.8750  
[det-tronics@carrier.com](mailto:det-tronics@carrier.com)