

Eagle Quantum Premier®
8 Channel Enhanced Discrete
Input/Output Module (EDIO)
Model EQ3730EDIO

DESCRIPTION

The 8 Channel EDIO Module is specially designed to expand the Input and Output capability of the Det-Tronics Eagle Quantum Premier® System.

The unit is designed to provide continuous and automated fire/gas protection, while ensuring system operation through continuous supervision of System Inputs/Outputs and Local Operating Network/Signaling Line Circuit (LON/SLC) Class X monitoring in the controller.

The EDIO module provides eight channels of configurable input or output points that can be programmed for supervised or unsupervised operation. Each input point can accept fire detection devices such as heat, smoke, or unitized flame detectors. Each output point can be configured for signaling or releasing output operation. Each channel on the module is provided with individual indicators for active and fault conditions.

IMPORTANT

For Class A wiring, two input/output channels are combined, thereby supporting up to four input/output circuits.

NOTE

An input must be active for at least 750 milliseconds in order to be recognized.

The EDIO module can be mounted directly to a panel, or it can be DIN rail mounted. System status can be determined using the trouble-shooting procedures, Eagle Quantum Safety System Software (S3) and the status indicators on the module.

THEORY OF OPERATION

Each channel on the EDIO module can be configured as an input to accept a connection from manual alarm stations, heat sensors, smoke sensors, pressure sensors, or as an output for notification or releasing.

Both input and output circuits can be configured as either a supervised or an unsupervised point. Each input point is also assigned a circuit type, such as: Alarm, Trouble, Supervisory, Gas High or Low Alarm, or other. The EDIO module reports to the EQP Controller and activates the appropriate static or user logic in the EQP Controller.

The EDIO module supports ANSI/NFPA 72:2010 Class X monitoring with the Eagle Quantum Premier Controller.

To ensure reliable system operation, the module can continuously monitor its input and output circuits for opens and short circuit conditions. The Eagle Quantum Premier Controller also continuously monitors the status of the EDIO module as well as the status of each device connected to the EDIO module.

LED INDICATORS

LEDs on the front panel of the EDIO are provided for indicating device status conditions. The LED's are tested upon power up to verify their operation. Red LEDs indicate an active condition. Yellow LEDs indicate trouble.

MOUNTING

The EDIO module is DIN rail or direct panel mountable for configurations requiring installation in NEMA or IP enclosures. DIN rail and mounting clip options must be specified at the time of order. Refer to the "Specifications" section for mounting arrangements and dimensions.

FEATURES

- Expands the capabilities of the Det-Tronics Eagle Quantum Premier® system
- Monitors eight independent I/O channels
- Individual channels are configurable as an Input or Output
- Individual channels are configurable as supervised or unsupervised points
- Supports Class A wiring when two channels are combined
- Individual point Type is configurable for alarm/supervisory/other inputs, notification/releasing output
- Individual channel LEDs indicate Active and Fault status
- Provides remote I/O capabilities via LON/SLC
- Panel or DIN rail mounting
- Power LED display
- Plug-in wiring connectors
- Meets the requirements of NFPA 72:2010
- RFI and EMI hardened (CE Marked).
- Supports up to eight conventional "two-wire" smoke/heat zones including the ability to reset latched zones. Does not require the use of "relay bases".

SPECIFICATIONS

POWER REQUIREMENTS—

3 watts nominal, 11 watts maximum.

INPUT VOLTAGE—

24 Vdc nominal, 18 to 30 Vdc. 10% overvoltage will not cause damage to the equipment.

21 to 30 Vdc for Pre-action / Deluge applications.

Note: For deluge and pre-action applications, input voltage to the device must be 21 Vdc minimum to ensure proper operation of the connected output device.

SLC OUTPUT—

Digital communication, transformer isolated (78.5 kbps).

TEMPERATURE RANGE—

Operating: -40°C to $+85^{\circ}\text{C}$ (-40°F to $+185^{\circ}\text{F}$).

Storage: -55°C to $+85^{\circ}\text{C}$ (-67°F to $+185^{\circ}\text{F}$).

HUMIDITY RANGE—

0 to 95% RH, non-condensing.

VIBRATION—

FM 3260-2000 (clause 4.9).

DIMENSIONS—

Refer to Figure 1.

SHIPPING WEIGHT—

1 lbs. (0.45 kg).

CERTIFICATION—

FM / CSA: Class I, Div. 2, Groups A, B, C, D (T4).
Class I, Zone 2, Group IIC (T4).



ATEX/CE: ATEX/EMC Directive Compliant.



II 3 G
Ex nA nC IIC T4 Gc EN 60079-29-1
DEMKO 05 ATEX 138864X
Tamb = -40°C to $+85^{\circ}\text{C}$.

IECEX: IECEX ULD 10.0004X.



Ex nA nC IIC Gc.
Tamb = -40°C to $+85^{\circ}\text{C}$.

SIL:



IEC 61508:2000
Certified SIL 2 Capable.
Applies to specific models –
Refer to the SIL 2 Certified
EQP Safety manual (95-8599).

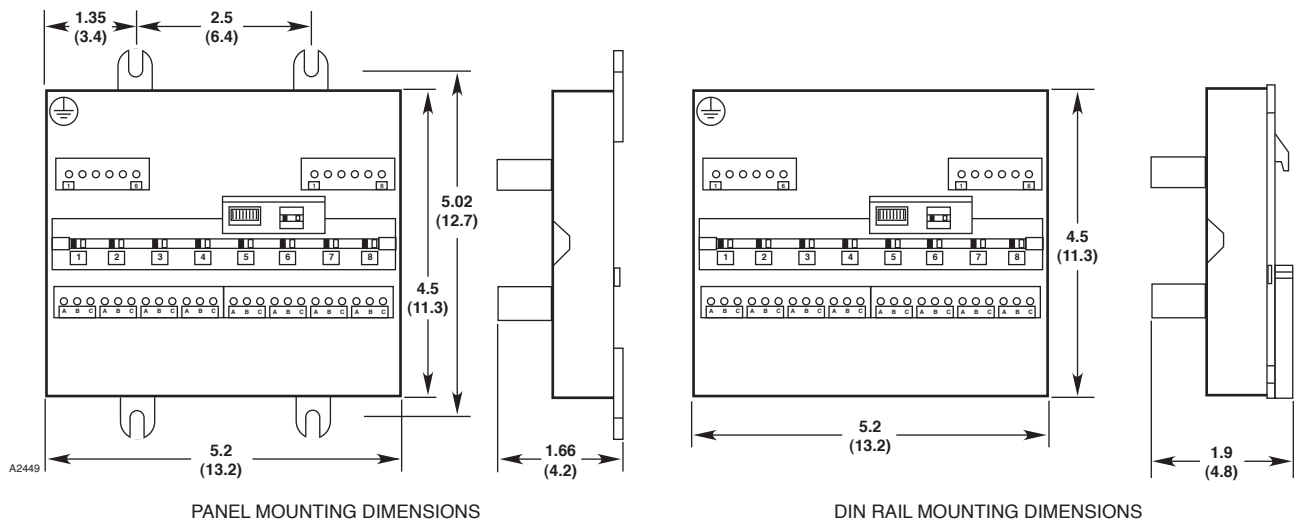

Figure 1—Dimensions of the EDIO Module in Inches (Centimeters)

INPUT / INITIATING DEVICE CIRCUITS

UNSUPERVISED INPUT—

Two state input (on/off).
Normally open contact.

SUPERVISED INPUT (Open Circuit)—

For Class A and Class B wiring.
Two state input (active/trouble):

- End of Line Resistor 10 K ohms nominal
- Open Circuit > 45 K ohms
- Active Circuit < 5 K ohms.

SUPERVISED INPUT (Open and Short Circuit)—

For Class A and Class B wiring.

Three State input (active/short/open):

- End of Line Resistor 10 K ohms nominal
- In Line Resistor 3.3 K ohms nominal
- Open Circuit > 45 K ohms
- Short Circuit < 250 ohms
- Active Circuit 2.5 K ohms to 5 K ohms.

INPUT, TYPES—

Configurable for static logic applications:

- Fire Alarm
- Supervisory
- Trouble
- High Gas Alarm
- Low Gas Alarm
- Other.

For Class A wiring on inputs, configure adjacent channels for Class A wiring and connect both channels to single contact device(s).

INPUT CIRCUITS – TWO WIRE SMOKE/HEAT TYPE—

Supervised Input, Class B:

Up to 15 two wire detectors per circuit.

Maximum line resistance 50 ohms.

5K ohm EOL.

Open circuit fault impedance 22k ohms.

OUTPUT / NOTIFICATION / RELEASING OR UNSUPERVISED DEVICE CIRCUITS

UNSUPERVISED OUTPUT RATING (Per Channel)—
2 amperes at 30 Vdc maximum.

Automatic short circuit protection provided.

Instantaneous short circuit current < 15 amperes.

Note: Voltage available at outputs is dependent on input voltage ($V_{out} \approx V_{in} - 0.5 \text{ Vdc}$).

OUTPUT—

Form “A” normally off.

RESPONSE TIME—

Output actuates in <0.15 second after acknowledging an alarm command message.

SUPERVISED OUTPUT RATING—SIGNALING CIRCUIT, CLASS A AND CLASS B WIRING

MAXIMUM OUTPUT CURRENT (Per Channel)—
2 amperes at 30 Vdc maximum.

Automatic short circuit protection provided.

Instantaneous short circuit current < 15 amperes.

SUPERVISORY CURRENT (Per Channel)—

Reverse current monitored at 1.5 mA, $\pm 0.5 \text{ mA}$.

RESPONSE TIME—

Output actuates in <0.15 second after acknowledging an alarm command message.

EOL RESISTORS—

10 K ohms $\pm 2 \text{ K ohms}$. Each circuit must have an EOL resistor.

SIGNALING OUTPUT, TYPES—

Configurable for device applications:

- Continuous
- 60 beats per minute
- 120 beats per minute
- Temporal Pattern.

Note: All eight channels are synchronized when programmed as a signaling output.

SUPERVISED OUTPUT RATING— Releasing Circuit, Class A and Class B wiring

MAXIMUM OUTPUT CURRENT (Per Channel)—

2 amperes at 30 Vdc maximum.

Automatic short circuit protection provided.

Instantaneous short circuit current < 15 amperes.

SUPERVISORY CURRENT (Per Channel)—

Monitored at 1.3 mA ±0.2 mA.

RESPONSE TIME—

Output actuates in <0.15 second after acknowledging an alarm command message.

RELEASING OUTPUT, TYPES—

Configurable for device applications:

- Continuous
- Timed.

For Class A wiring on outputs, configure adjacent channels for Class A wiring and connect both channels to single output device(s).

INSTALLATION

All electrical connections are made to the field wiring connectors furnished with the module. Refer to Figure 2 for identification of module wiring terminals.

Connector P1, Terminals 1 to 6 24 Vdc Power Input

Connect the module power supply to terminals 1 and 2. If additional terminals are required for powering other devices, these devices should be connected to terminals 4 and 5. Shields are to be connected to terminals 3 and 6 — chassis (earth) ground terminals. Terminals are rated for 10 amperes. Use both sets of input terminals in parallel if total output current can exceed 10 amperes.

Connector P2, Terminals 1 to 6 LON/SLC Signaling Circuit Terminals

Be sure to observe polarity when wiring the LON/SLC shield connection — terminals 3 and 6.

1 — “A” side of signaling circuit for COM 1

2 — “B” side of signaling circuit for COM 1

4 — “A” side of signaling circuit for COM 2

5 — “B” side of signaling circuit for COM 2

Connector P3, Terminals 1 to 12 Terminals A,B & C

Channels 1 to 4 Input / Output Terminals

Refer to individual wiring configurations for terminal descriptions. Only channel 1 is shown in each diagram. The information is typical for channels 2-8.

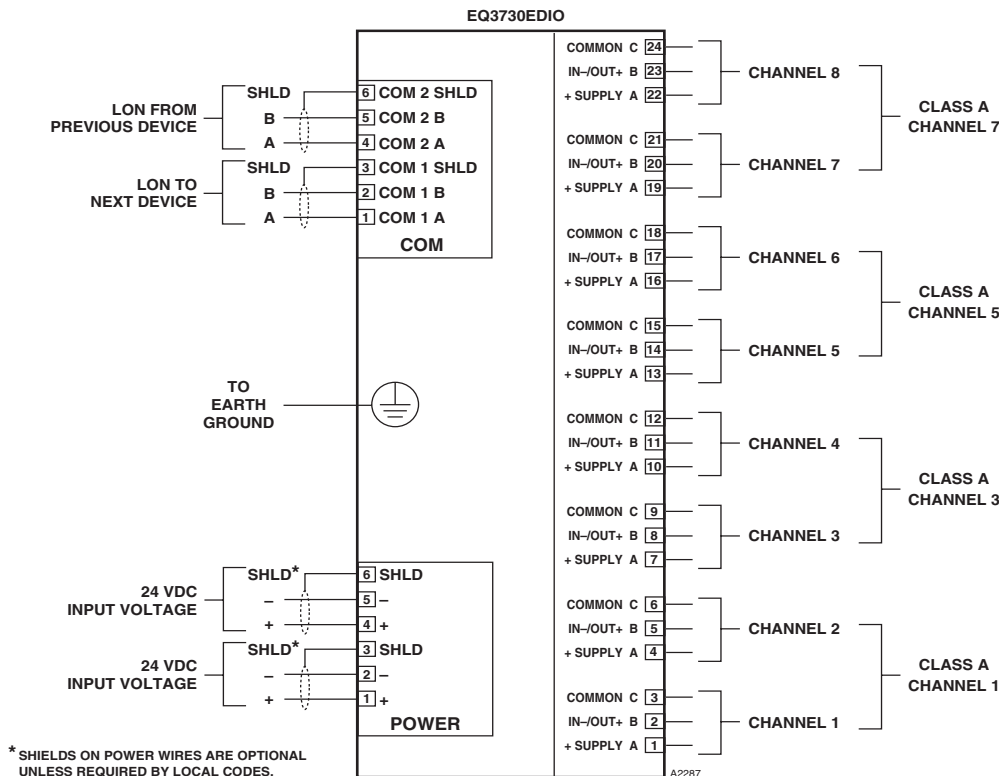

Figure 2—EDIO Module Wiring Terminals

Connector P4, Terminals 13 to 24
Terminals A, B & C

Channels 5 to 8 Input / Output Terminals

Refer to individual wiring configurations for terminal descriptions. Only channel 1 is shown in each diagram. The information is typical for channels 2-8.

Unsupervised Input

Connect external system wiring to the appropriate terminals on the terminal block. See Figure 3.

The input to the EDIO consists of one or more normally open or normally closed switches. An EOL resistor is not required.

Make no connection to “+ Supply” terminal.

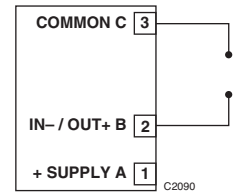

Figure 3—Unsupervised Input Configuration

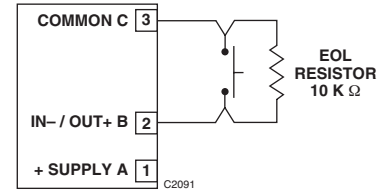

Figure 4—Supervised Input Configuration – Class B

Supervised Input (IDC) Open Circuit Supervision

Connect external system wiring to the appropriate terminals on the terminal block. For Class B wiring, see Figure 4. For Class A wiring, see Figure 5. Note that two channels are used for one circuit.

The input to the EDIO module consists of one or more normally open switches, with a 10 K ohm, 1/4 watt EOL resistor in parallel across the last switch.

Make no connection to “+ Supply” terminal.

Supervised Input Open and Short Circuit Supervision

Connect external system wiring to the appropriate terminals on the terminal block. For Class B wiring, see Figure 6. For Class A wiring, see Figure 7. Note that two channels are used for one circuit.

The input to the EDIO module consists of normally open switches, with a 10 K ohm, 1/4 watt EOL resistor in parallel across the return channel, and a 3.3 K ohm, 1/4 watt resistor in series with each switch.

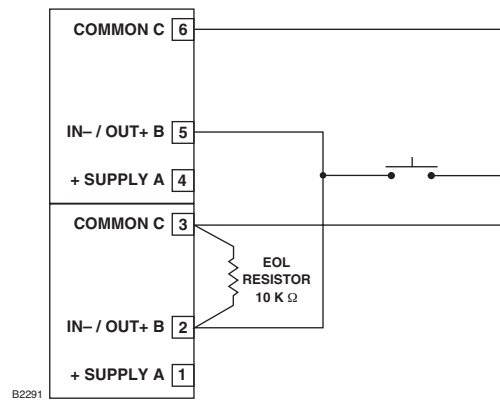

Figure 5—Supervised Input Configuration – Class A

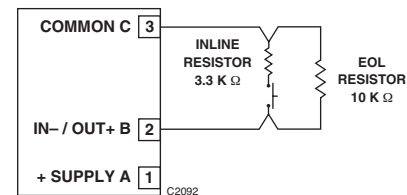

Figure 6—Supervised Input Configuration (Opens and Shorts) – Class B

NOTE

If using more than one switch, the first active condition (switch closed) must be latched. Any subsequent closed switch will indicate a short circuit fault condition.

Make no connection to “+ Supply” terminal.

Input — Deluge and Pre-Action

The initiating device circuit(s) for use with the deluge and pre-action system configuration must use Class A wiring or be wired within 20 feet (6.1 m) and in conduit from the EDIO. See Table 2 for a list of FM Approved solenoids for deluge and pre-action applications.

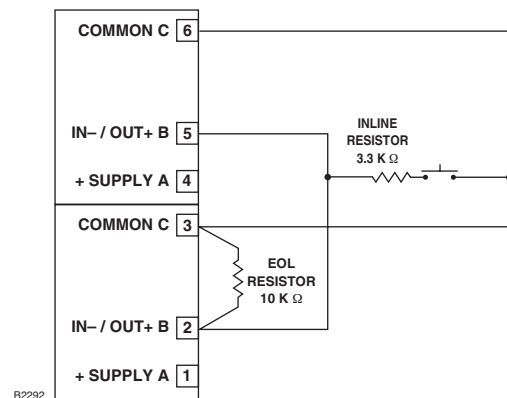

Figure 7—Supervised Input Configuration (Opens and Shorts) – Class A

Two-Wire Smoke Detectors

The EDIO supports 2-wire devices from Kidde-Fenwal and Apollo. Figure 8 shows the wiring for Apollo detectors connected to EDIO Channel 1 through terminals 1 and 2.

Figure 9 shows the typical wiring for Kidde-Fenwal detectors connected to the EDIO through Channel 1 using terminals 1 and 2.

The EDIO supports either brand of detection products, however, mixing brands is not supported on either a single channel or module.

IMPORTANT

No more than 15 devices can be connected per channel.

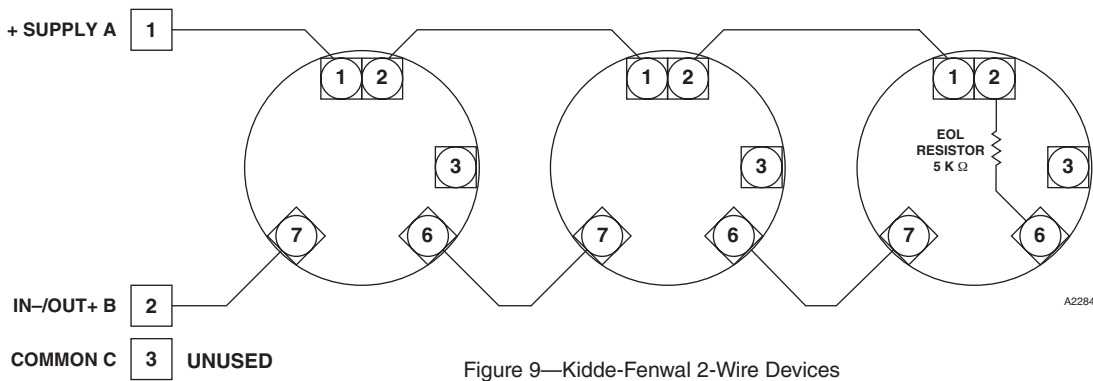
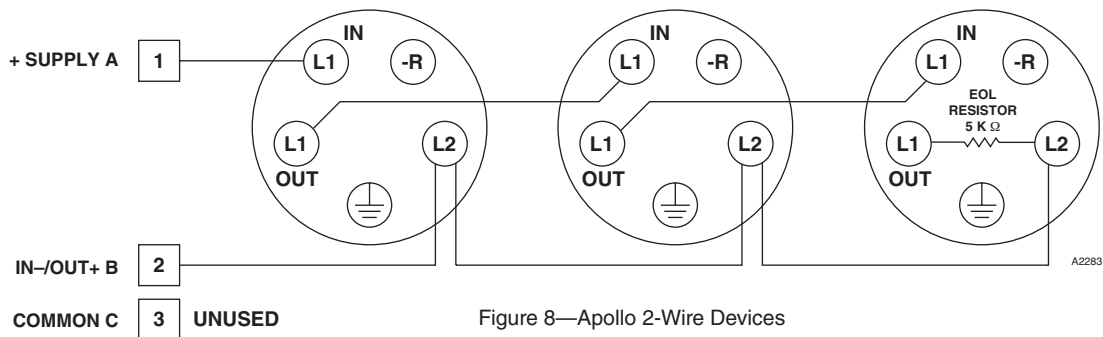

Unsupervised Output

Connect external system wiring to the appropriate terminals on the terminal block. See Figure 10.

No connection should be made to “+ Supply” terminal.

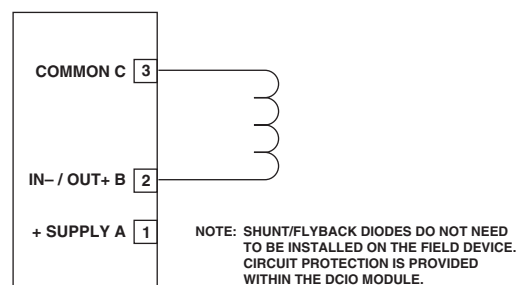

Figure 10—Unsupervised Output Configuration

**Supervised Output—
Notification Supervised for Open & Short Circuits**

Connect external system wiring to the appropriate terminals on the terminal block. For Class B wiring, refer to Figure 11.

For Class A wiring, refer to Figure 12. Note that two channels are used for one output circuit.

The output of the EDIO module supervises the notification circuit by reversing the polarity of the monitoring circuit. Polarity must be observed when connecting the notification device. It is essential to utilize a notification device approved for fire alarm notification. These devices are polarized and would not require the use of an external diode for the supervision of the circuit. Wire one or more notification devices to the output, with a 10 K ohm, 1/4 watt EOL resistor in parallel across the last device.

No connection should be made to “+ Supply” terminal.

Each output channel is individually activated for response pattern:

- supervisory
- continuous output
- 60 beats per minute
- 120 beats per minute
- temporal
- timed
- trouble.

**Supervised Output—
Agent Release**

Connect external system wiring to the appropriate terminals on the terminal block. For Class B wiring, refer to Figure 13.

For Class A wiring, refer to Figure 14. Note that two channels are used for one output circuit. Trouble indication is provided for any open wire and the output can still be activated with a single open wire.

Wire one or more releasing devices to the module output.

No connection should be made to “+ Supply” terminal.

The output of the EDIO module supervises the releasing circuit via the coil of the releasing solenoid. It is essential to utilize a releasing device approved for use with this output module. This type of output does not require the use of EOL resistors or diodes to supervise the circuit.

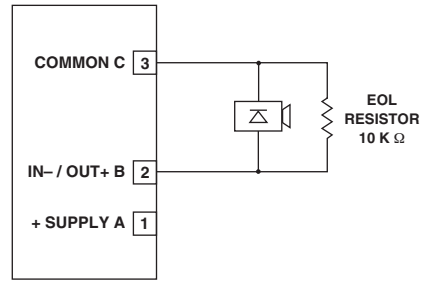

Figure 11—Supervised Output Configuration (Notification)—
Class B

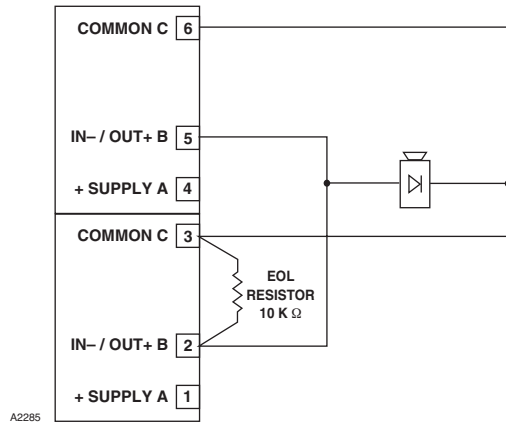

Figure 12—Supervised Output Configuration (Notification)—
Class A

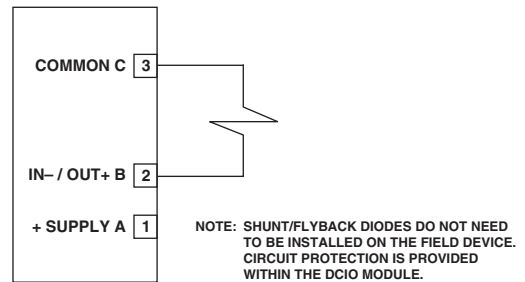

Figure 13—Supervised Output Configuration (Agent Release)

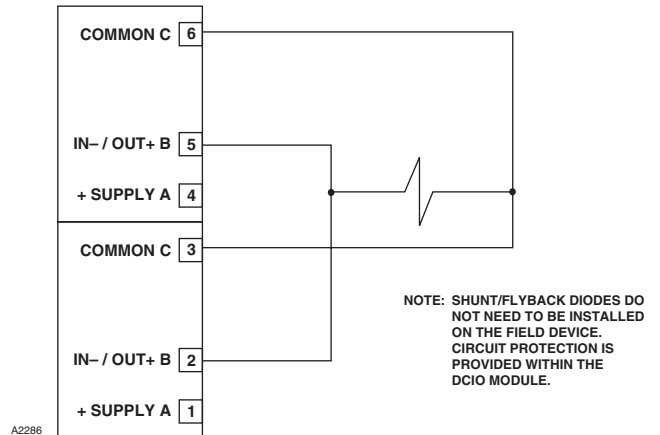

Figure 14—Supervised Output Configuration (Agent Release)—
Class A Wiring

The output can be configured for latching, continuous, supervisory, trouble or timed response.

To ensure adequate operating voltage for the output device, the maximum wiring length from the power source to the output device must not exceed the values shown in Table 1 for automatic release applications. (For solenoids, this wire length includes both the wiring from the power supply to the EDIO module and the wiring from the module to the solenoid.)

Supervised Output for Deluge and Pre-action

To ensure proper operating voltage, the input voltage to the EDIO must be in the range from 21 to 30 Vdc and the maximum wiring length must not exceed the values shown in Table 2 for deluge and pre-action applications. Per FM Approval requirements, the secondary power must provide capacity for a 90 hour minimum standby operation followed by a minimum of 10 minutes of releasing and alarm operation. **The initiating device circuit(s) for use with the deluge and pre-action system configuration must use Class A wiring or be wired in conduit within 20 feet from the EDIO.**

ORDERING INFORMATION

When ordering, please specify:

EQ3730EDIO 8 Channel Enhanced Discrete Input/Output Module

Options Panel Mount
 DIN Rail Mount
 EOL Resistors
 Inline Resistors

For additional information or for assistance in designing a system to meet the needs of a specific application, please contact:

Detector Electronics Corporation
 6901 West 110th Street
 Minneapolis, Minnesota 55438 USA
 Operator: (952) 941-5665 or (800) 765-FIRE
 Customer Service: (952) 946-6491
 Fax: (952) 829-8750
 Web site: www.det-tronics.com
 E-mail: det-tronics@det-tronics.com

Table 1—Maximum Wire Length for Releasing Applications

Device	Maximum Wire Length in Feet			
	12 AWG	14 AWG	16 AWG	18 AWG
890181*	150	100	60	
899175*	150	100	60	
895630-000*	150	100	60	
897494*	190	120	75	
570537**	3000	1900	1200	750
2 Amp Load	190	120	75	

*Fenwal Solenoid

**Ansul Solenoid

Table 2—Maximum Wire Length for FM Approved Solenoids for Deluge and Pre-Action Applications

Solenoids			Maximum Wire Length in Feet (Meters)			
FM Solenoid Group	Manufacturer	Model	12 AWG	14 AWG	16 AWG	18 AWG
B	ASCO	T8210A107	183 (56)	115 (35)	72 (22)	46 (14)
D	ASCO	8210G207	314 (96)	198 (60)	124 (38)	78 (24)
E	Skinner	73218BN4UNLVNOC111C2	331 (101)	208 (63)	131 (40)	82 (25)
F	Skinner	73212BN4TNLVNOC322C2	130 (40)	82 (25)	51 (16)	32 (10)
G	Skinner	71395SN2ENJ1NOH111C2	331 (101)	208 (63)	131 (40)	82 (25)
H	Viking	HV-274-0601	180 (55)	110 (34)	70 (21)	45(14)

Specifications subject to change without notice.

All trademarks are the property of their respective owners.
 © 2020 Detector Electronics Corporation. All rights reserved.

Det-Tronics manufacturing system is certified to ISO 9001—
 the world's most recognized quality management standard.



Corporate Office
 6901 West 110th Street
 Minneapolis, MN 55438 USA
www.det-tronics.com

Phone: +1 952.941.6665
 Toll-free: +1 800.765.3473
 Fax: 952.829.8750
det-tronics@carrier.com