

Instructions

95-8493-02

Dual Spectrum® Infrared Flame Detector
PM-5MP & PM-5MP+



Table of Contents

APPLICATIONS	1
DETECTOR USE IN HAZARDOUS AREAS	2
ELECTRICAL CHARACTERISTICS.....	2
ENVIRONMENTAL CHARACTERISTICS	3
DETECTOR PERFORMANCE	3
Detection Range and Response Time	3
False Alarm Immunity	4
DETECTOR INSTALLATION	4
Physical Mounting	4
Electrical Wiring Connection	4
Intrinsically Safe Circuits	5
Nonincendive Circuits	5
System Test.....	5
Optional Test Method	6
TROUBLESHOOTING	6
MAINTENANCE	6
Routine Visual Inspection	6
Periodic System Test.....	6
DEVICE REPAIR AND RETURN	7
ORDERING INFORMATION.....	7

APPENDIX A	
CONTROL DRAWING CONFIGURATION	8

APPENDIX B	
INTRINSICALLY SAFE CLASS B, STYLE B WIRING	9

APPENDIX C	
NON-INCENDIVE CLASS B, STYLE B WIRING	10

APPENDIX D	
NON-INCENDIVE CLASS A, STYLE D WIRING	11

APPENDIX E	
PSS-MP TEST SET	12

List of Illustrations

Figure 1	Dimensions of PM-5MP and PM-5MP+ Detectors	2
Figure 2	Graphical Representation of Detector Range as a Function of Angle from the Optical Axis	3
Figure 3	Testing a PM-5MP with the PSS-MP Test Set	5
Figure A1	Control Drawing Configuration (Drawing No. 420031)	8
Figure B1	Intrinsically Safe Class B, Style B Wiring (Drawing No. 420032)	9
Figure C1	Non-Incendive Class B, Style B Wiring (Drawing No. 420033)	10
Figure D1	Non-Incendive Class A, Style D Wiring (Drawing No. 420034)	11
Figure E1	PSS-MP Test Set	12

List of Tables

Table 1	PM-5MP and PM-5MP+ Wiring Harness Identification	3
Table 2	Detection Distances	3
Table 3	False-Alarm Immunity Distances	4
Table 4	Maximum Wiring Distances	5
Table 5	Troubleshooting Guide	6

Dual Spectrum® Infrared Flame Detector PM-5MP & PM-5MP+

IMPORTANT

Be sure to read and understand the entire instruction manual before installing or operating the Model PM-5MP and PM-5MP+ Detectors. Only qualified personnel should install, maintain or operate the flame detection system.

CAUTION

The wiring procedures in this manual are intended to ensure proper functioning of the device under normal conditions. However, because of the many variations in wiring codes and regulations, total compliance to these ordinances cannot be guaranteed. Be certain that all wiring complies with the NEC as well as all local ordinances. If in doubt, consult the authority having jurisdiction before wiring the system.

The Dual Spectrum® PM-5MP and PM-5MP+ are Factory Mutual Approved infrared flame detectors that provide reliable flame detection in semiconductor fabrication facilities and other manufacturing environments. They provide fast protection against fires, have a maximum 110° field-of-view, and are Approved for use in hazardous (classified) locations as described below. The detector response to explosive fires is as fast as 25 milliseconds.

The PM-5MP (medium sensitivity) P/N 420021 and the PM-5MP+ (high sensitivity) P/N 420737 are encapsulated and enclosed in an extremely compact molded polypropylene housing approximately 3.1 x 3.1 x 1.5 inches in size. (See Figure 1.) They are intended for mounting in locations where space is at a premium. The IP67 polypropylene housing is resistant to attack by a broad range of chemicals. The housing has four holes in the mounting flange that allow it to be attached to a bracket or other flat surface. Electrical connections are made via an integral multiconductor cable.



Factory Mutual Approvals (FMA) has Approved:

- 1) the performance of the flame detector (per 3260),
- 2) the compliance with National Fire Protection Association (NFPA) Standard 72 of the detectors and the installation described in this document,
- 3) the suitability for use in protected semiconductor fabrication areas, as described in the FM Loss Prevention Data Sheets 7-7/17-12, and
- 4) the suitability of the installation for use in hazardous (classified) locations.

NOTE

These detectors are specifically tuned and tested to respond to fires as described in this manual. The detector response to other fuel sources not described in this manual may vary. Please contact Detector Electronics Corporation for further information.

APPLICATIONS

The PM-5MP and PM-5MP+ are intended for fast detection of hydrocarbon fueled fires in harsh chemical environments. The detector is ideal for semiconductor wet benches and is suitable for clean-room and other indoor applications.



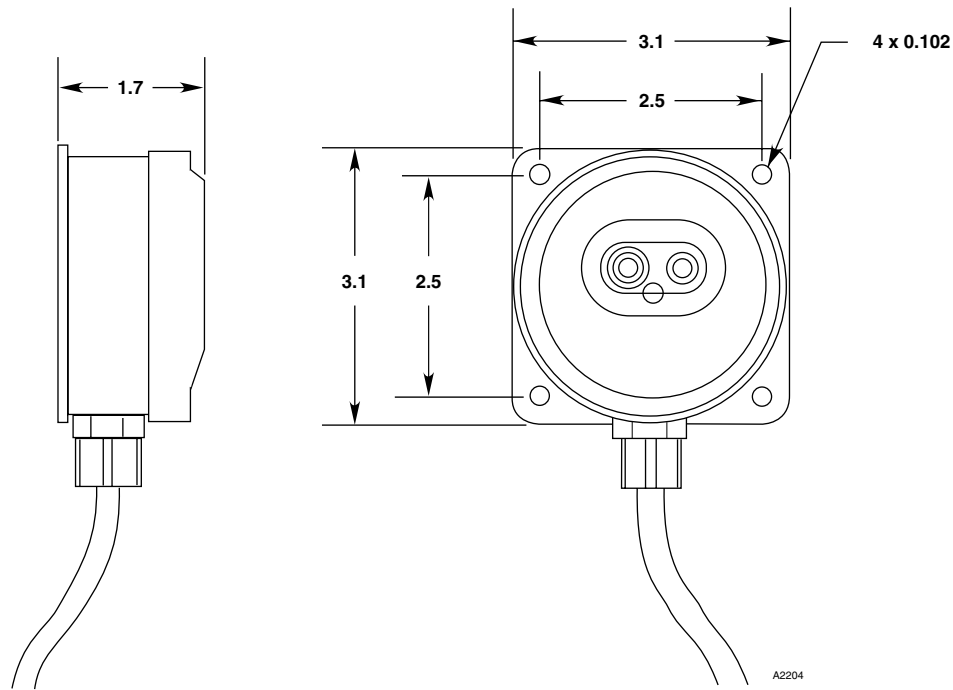

Figure 1—Dimensions of PM-5MP and PM-5MP+ Detectors

DETECTOR USE IN HAZARDOUS AREAS

The Dual Spectrum® Models PM-5MP and PM-5MP+ are Factory Mutual Approved to 3260, intrinsically safe for use in Class I, II, III, Division 1, Groups C, D, E, F & G hazardous (classified) locations; non-incendive for use in Class I, Division 2 Groups A, B, C & D locations and suitable for use in Class II/III Division 2, Groups F & G. This Approval depends on proper installation and choice of components, which are described in this installation manual. See the following sections and Control Drawing Configuration (Appendix A) for installation instructions and component selection criteria.

ELECTRICAL CHARACTERISTICS

The PM-5MP and PM-5MP+ are designed to interface to any NFPA type fire alarm control panel. A normally open contact is provided for an alarm signal. The alarm contacts close for a minimum of five and a maximum of 15 seconds when a fire is detected and are automatically reset after a fire. An internal supervision contact closes when the detector powers up and opens if a detector fault (such as loss of power or low power supply voltage) occurs. In NFPA 72, Class A or B circuits (see Appendix B to D), such a fault condition is indicated at the control panel as a trouble signal. A blinking red LED on the front of the housing indicates normal operation with no faults.

OPERATING VOLTAGE—

9 to 30 VDC at the detector (observe polarity), including line drops and ripple.

NOTE

Detector output is not guaranteed below 9 VDC. The status LED and relay will reflect this condition.

POWER CONSUMPTION—

10 milliamps maximum at +30 VDC.

ALARM OUTPUT—

Alarm relay is non-latching. Contacts close for 5 to 15 seconds.

TROUBLE OUTPUT—

Opening of normally closed relay contacts.

RELAY CONTACT RATINGS—

100 milliamps at 30 VDC

STABILIZATION TIME—

Maximum 0.5 second after power up.

WIRING HARNESS—

Identification: See Table 1.
 Length: 50 feet (15 m).
 Diameter: 0.3 inches (7.6 mm).
 Individual Wires: 20 AWG, solid.

Table 1—PM-5MP and PM-5MP+ Wiring Harness Identification

Wire Color	Description
Black	Power Return
Brown	Power Return
Red	V+, Input Power
Orange	V+, Input Power
Yellow	Alarm +
Green	Alarm +
Blue	Alarm –
Violet	Alarm –
Gray	Trouble +
White	Trouble –

T0044

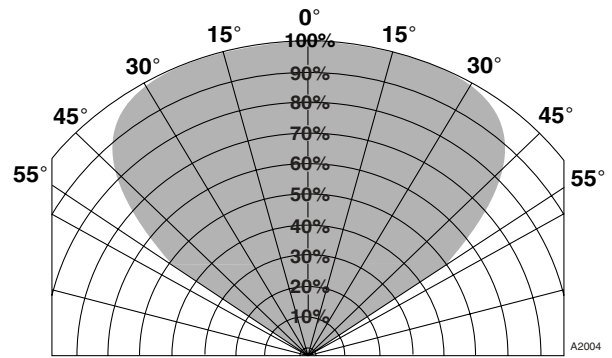

Figure 2—Graphical Representation of Detector Range as a Function of Angle from the Optical Axis

ENVIRONMENTAL CHARACTERISTICS

TEMPERATURE RANGE—

(Operating and Storage) 32° F to +158° F (0° C to +70° C).

RELATIVE HUMIDITY—

0 to 100% relative humidity.

NOTE

Water or other liquids on the face of the detector may decrease sensitivity.

ENCLOSURE RATING—

IP67.

VIBRATION—

Compliance with FMR Approval Standard 3260.

CE—

Conforms to all relevant European norms.

ELECTROMAGNETIC INTERFERENCE—

Highly resistant to radiated and conducted Electromagnetic Interference (EMI). The detectors are immune to radiated fields of 100 volts per meter, including amplitude and frequency modulated (AM & FM) signals in the frequency range of 1 MHz to 1 GHz. The detectors can operate in the presence of conducted noise levels up to 1.0 VRMS in the frequency range of 30 Hz to 250 kHz while the input voltage, including noise, remains between 9 and 30 volts.

Table 2—Detection Distances (Factory Mutual Research Verified)

Fuel	Size	PM-5MP Medium Sensitivity Range(ft)	PM-5MP+ High Sensitivity Range (ft)
Gasoline	12 x 12 inch	12	20
Isopropyl Alcohol	4 in. diameter	2	2.5
Isopropyl Alcohol	8 in. diameter	5	9
Isopropyl Alcohol	24 x 24 inch	20	38
Acetone	4 in. diameter	2	2.5
Acetone	8 in. diameter	5	9
Cyclohexanone	8 in. diameter	5	9
Polypropylene	4 in. diameter	1.5	3
Polypropylene	8 in. diameter	4	10
Photo Resist (Microposit 1805)	8 in. diameter	4	7.5
N-Methyl-2-Pyrrolidone (NMP)	8 in. diameter	4	6
Resist Remover (Microposit 1165)	8 in. diameter	4	6
Propylene Glycol Monomethyl Ether Acetate	8 in. diameter	4	7
Methyl Alcohol	8 in. diameter	3	5
Ethyl Lactate	8 in. diameter	3	5.5
Dimethyl Sulfoxide (DMSO)	8 in. diameter	3	4.5
Hydrogen Flare	24 inch tall	2	5
Silane	30 inch tall	4	>4*
Photo-Etch (DATAK ER-71 Spray Developer)	8 in. diameter	3*	10.5

*Not Factory Mutual witnessed.

DETECTOR PERFORMANCE

DETECTION RANGE AND RESPONSE TIME

Best performance is achieved when the detector is mounted so that the protected area is within the range, or detection threshold distance, given in Table 2 for various flammable hazards, and within the 110° field of view. See Figure 2. The PM-5MP and PM-5MP+ detectors can respond to fires in as little as 25 milliseconds. Actual detection times of fires depends on the source of fuel, ignition sources and other aspects of the initial fire stages. The detector has a typical response time of one second to the fires specified in Table 2. The detector can respond most quickly to closer or larger fires, but is unlikely to detect the fires specified in Table 2 when they are further away than shown. The range is smaller for sources when they are close to the edge of the field of view of the detector. At the edge ($\pm 55^\circ$) the range is reduced no more than 50%.

NOTE

The detector range to fires not listed in Table 2 will vary and should be verified by fire tests using the fuel in question. Please contact Detector Electronics Corporation for further information.

FALSE ALARM IMMUNITY

The PM-5MP and PM-5MP+ are highly resistant to false alarms. However, no flame detector is perfect — a fire alarm output due to non-fire stimuli is possible. Table 3 lists common stimuli and the false alarm immunity distance for those stimuli, as tested by Factory Mutual Research. No false alarms occur for larger distances in laboratory measurements.

For best performance, the detector should be mounted so that any exposure to these sources occurs at distances at least as large as those given in Table 3. In addition, to ensure optimum performance, detectors should be mounted so that they do not view very brightly illuminated areas. For example, indoor mounting locations where the detectors look out doors or windows should be avoided wherever possible.

Table 3—False Alarm Immunity Distances
(Factory Mutual Research Verified)

Stimulus (Modulated or Unmodulated)	PM-5MP Medium Sensitivity Range (in)	PM-5MP+ High Sensitivity Range (in)
Sunlight through Glass	No Response	No Response
Flashlight (3 D-Cell Maglite)	No Response	No Response
Vehicle Headlight	12	12
Electronic Flash (Sunpak 411/Vivitar 5200)	6	6
Arc Welding (5/32" Steel Rod, 140 A)	30	40
Radiant Heater, Quartz (1500 W)	48	62
Brightly Colored Clothing	No Response	No Response
Fluorescent (40 W / 68 W)	No Response	No Response
Incandescent Light (100 W Frosted)	3	3
Flood Light	36*	72**
Sodium-Vapor Lamp (70 W / 250 W)	3	3
Forced Air Heater (1500 W)	24	24

*Sungun-II, 650 W

**Nite Tracker, Quartz Halogen, 1.5 M Candlepower

DETECTOR INSTALLATION

PHYSICAL MOUNTING

The PM-5MP and PM-5MP+ must be installed in conformance with the appropriate drawing provided in this manual, NFPA-72, the NEC, and all local codes for the hazard classification of the location to be protected. The detectors come with an integral multi-conductor cable for the alarm and power circuits.

CAUTION

The factory sealed front cover is essential to the approval of the detectors. Removing this cover will compromise the performance of the detector.

The compact package of the PM-5MP and PM-5MP+ is of great benefit in applications where space is a limiting factor. It has four holes in the mounting flange that can be used to mount the detector directly to a flat surface or bracket. Take care not to over-tighten mounting hardware.

The number of detectors required to protect a given area will depend on the size of the area, the distance from the detector and the size and type of the fire threat. Certain factors need to be considered when designing an installation:

1. The detectors should be mounted so that objects do not block their field of view. This includes glass, plexiglass and other visibly transparent materials.
2. Whenever possible, detectors should be mounted so their ranges and fields of view overlap.

3. Detectors should be mounted so they will not be blocked by moving machinery or personnel during normal operations within the area.
4. To ensure optimum sensitivity and performance, detectors should be mounted so they do not view brightly illuminated areas.
5. The detectors should be mounted so that they are easily and safely accessible for inspection and maintenance.
6. If mechanical or high-temperature damage, or window contamination is likely in the installed location, then the detectors should be protected. However, the protection method cannot obstruct the detector's field of view with any material, including visibly transparent materials like glass and plexiglass.
7. The detectors can be mounted in any orientation, so long as the manufactured mounting points are the point of support.
8. Mounting the detectors so that they point below horizontal is recommended, as this generally results in minimal window contamination. When practical mount the detector with the cable entry pointing below horizontal.

ELECTRICAL WIRING CONNECTION

An approved installation of the PM-5MP and PM-5MP+ flame detectors must be in accordance with the FM Approved drawings included as appendices to this manual and all local codes. The required drawing for specific hazardous (classified) or non-hazardous locations can be determined from the Control Drawing Configuration

(Drawing 420031, Appendix A). Detectors may be wired in a standard NFPA class B, style B configuration or in a class A, style D configuration. Approved initiating device circuits may be either intrinsically safe, nonincendive, or suitable for the classified location as required.

INTRINSICALLY SAFE CIRCUITS

Intrinsically safe installations require the use of suitable and approved barriers, an approved fire alarm control panel that is compatible with the barriers, and wiring methods consistent with ANSI/ISA-RP12.6 and other code. Appendix B calls out the type and quantity of barriers required for installation in hazardous (classified) locations and shows the electrical interconnection to an NFPA compliant fire alarm control panel. Wiring that passes from the non-hazardous location to the hazardous location should pass through a seal appropriate for the type of hazard. All control room instrumentation must operate at less than 250 VRMS.

The barriers may be located in the main control panel or in a separate enclosure, but adequate separation between intrinsically safe and non-intrinsically safe wiring must be observed as defined by ANSI/ISA-RP12.6. Barrier grounds should be connected separately to the same grounding location.

All initiating device wiring should be run in its own separate raceway. Table 4 gives the maximum one way wiring distances based on wire and barrier resistance. It is also important not to exceed the maximum inductance and capacitance listed on the intrinsic safety barriers. This may restrict the maximum cable length to less than the values listed in Table 4. Consult Appendix B for further instructions.

NONINCENDIVE CIRCUITS

In Class I, Division 2, Group A, B, C, & D locations, the detector may be installed in nonincendive circuits. It is also suitable for installation in Class II/III, Division 2, Group F & G hazardous locations. Installations require the use of an approved fire alarm control panel that is compatible with the Class B, Style B and/or Class A, Style D initiating device circuits. See Appendix C and D.

NOTE

ANSI/NFPA 70 (NEC) Article 501-4(b) requires the use of enclosed gasketed wireways.

SYSTEM TEST

After the fire protection system is installed, it should be tested for correct operation. The detectors may be tested with live fires or by using the hand-held model PSS-MP Test Set P/N 420116. The details of this sequence will vary with particular installations, but the procedure must include the following steps. See Appendix E.

Table 4—Maximum Wiring Distances

AWG (Solid)	Maximum One Way Wiring Distance in Feet (Excluding Integral Cable)
14–18	1000
20	600
22	400

T0047

PSS-MP Test Procedure

WARNING

A full system test results in an alarm output. This will result in the automatic suppression system being activated if it is not disabled prior to testing.

1. **Suppression System.** Disable the suppression system if its activation is not desired during this test.

WARNING

Do not use the PSS-MP Test Set unless the area is known to be non-hazardous.

2. **Operation of PSS-MP Test Set.** Turn on the PSS-MP and wait at least 15 seconds. Direct the beam into the front of the detector to cause an alarm output. Hold the PSS-MP so that the infrared filter is less than 1 inch from the front of the flame detector to be tested as shown in Figure 3. See Appendix E for more detailed information.
3. **Fire Response.** Expose the sensor under test to a PSS-MP as described in Step 2. The control panel should indicate an alarm condition for the position or zone corresponding to the sensor.



Figure 3—Testing a PM-5MP with the PSS-MP Test Set

4. **Interconnection Wiring.** Correct interconnection wiring should be checked by disconnecting any wire from the multi-conductor cable where it is connected to the power or alarm circuit. The result, in an approved wiring scheme, should be a trouble signal indication at the control panel.
5. **Restore Fire Protection System.** Restore the system to an operational condition after all tests have been completed.

OPTIONAL TEST METHOD

With the detector powered up, the following tests can be done. False alarm immunity can be checked using stimuli and distances shown in Table 3. Fire response can be checked by exposing the detector under test to a live fire source. See Table 2. Follow all required precautions when testing in this manner.

TROUBLESHOOTING

See Table 5.

MAINTENANCE

ROUTINE VISUAL INSPECTION

A properly installed PM-5MP detector system is highly resistant to blinding by contamination build-up on the detector front face window. However, a thick enough build-up will begin to reduce the performance of the detector. This can be prevented by periodically inspecting installed detectors visually for contamination build-up on the detector front face. If such a build-up is observed, it should be removed by cleaning the detector front face window with a soft cloth or lens tissue. The minimum inspection period should be compatible with appropriate regulating agency requirements.

PERIODIC SYSTEM TEST

The authority having jurisdiction and internal facility requirements generally call for routine testing of safety systems at defined intervals, which, at a minimum, should conform to the requirements of NFPA 72. These tests should include visual inspections and the steps listed in the System Test section above.

WARNING

A full system test results in an alarm output. This will result in the suppression system being activated if it is not disabled prior to testing.

Table 5—Troubleshooting Guide

Symptom	Probable Cause	Corrective Action
Trouble signal at fire alarm control panel.	Incorrect wiring.	Check circuit installation.
	Low or no voltage to detector.	Check voltage of Red or Orange wire with respect to the Black or Brown wire. Should be 9 to 30 vdc.
	Detector malfunction.	Replace Detector.
Detector does not alarm during FIRE RESPONSE test with PSS-MP.	Incorrect wiring	Check circuit installation.
	PSS-MP temperature different from detector.	Allow detector and PSS-MP temperatures to stabilize. Turn on PSS-MP at least 15 seconds prior to test.
	Low Batteries in PSS-MP.	Replace batteries and retest.
	Detector malfunction.	Replace detector.
Red LED out.	Incorrect wiring or incorrect power to the detector.	Check circuit installation.
	Detector malfunction	Replace detector.

T0048

DEVICE REPAIR AND RETURN

The PM-5MP and PM-5MP+ are not designed to be repaired in the field. If a problem should develop, carefully check for proper system wiring. If it is determined that the problem is caused by a detector failure, the device must be returned to the factory for repair.

Prior to returning devices or components, contact the nearest local Detector Electronics office so that a Service Order number can be assigned. A written statement describing the malfunction must accompany the returned device or component to expedite finding the cause of the failure.

Pack the unit or component properly. Use sufficient packing material in addition to an anti-static bag or aluminum-backed cardboard as protection from electrostatic discharge.

Return all equipment transportation prepaid to the factory in Minneapolis.

ORDERING INFORMATION

When ordering, please specify:

PM-5MP (medium sensitivity) or PM-5MP+ (high sensitivity) Dual Spectrum® Infrared Flame Detector

For assistance in ordering a system to meet the needs of a specific application, contact:

Detector Electronics Corporation
6901 West 110th Street
Minneapolis, Minnesota 55438 USA
Operator: (952) 941-5665 or (800) 765-FIRE
Customer Service: (952) 946-6491
Fax: (952) 829-8750
Web site: www.detrronics.com
E-mail: detrronics@detrronics.com

APPENDIX A

Control Drawing Configuration

PM-5MP & PM-5MP+ CONTROL DRAWING CONFIGURATION			
HAZARDOUS (CLASSIFIED) LOCATION	NFPA 72 INITIATING DEVICE CIRCUIT CLASS & STYLE	INSTALLATION TYPE	CONTROL DWG NO.
CLASS I, DIV. 1, GROUPS C & D	CLASS B, STYLE B	INTRINSICALLY SAFE	420032
CLASS II, DIV. 1, GROUPS E, F & G	CLASS B, STYLE B	INTRINSICALLY SAFE	420032
CLASS I, DIV. 2, GROUPS A, B, C & D	CLASS B, STYLE B	INTRINSICALLY SAFE	420032
CLASS II, DIV. 2, GROUPS F & G	CLASS B, STYLE B	INTRINSICALLY SAFE	420032
CLASS III, DIV. 2	CLASS B, STYLE B	INTRINSICALLY SAFE	420032
CLASS I, DIV. 2, GROUPS A, B, C & D	CLASS B, STYLE B	NON-INCENDIVE	420033
CLASS II, DIV. 2, GROUPS F & G	CLASS B, STYLE B	NON-INCENDIVE	420033
CLASS III, DIV. 2	CLASS B, STYLE B	NON-INCENDIVE	420033
NON-HAZARDOUS (UNCLASSIFIED)	CLASS B, STYLE B	NON-INCENDIVE	420033
CLASS I, DIV. 2, GROUPS A, B, C & D	CLASS A, STYLE D	NON-INCENDIVE	420034
CLASS II, DIV. 2, GROUPS F & G	CLASS A, STYLE D	NON-INCENDIVE	420034
CLASS III, DIV. 2	CLASS A, STYLE D	NON-INCENDIVE	420034
NON-HAZARDOUS (UNCLASSIFIED)	CLASS A, STYLE D	NON-INCENDIVE	420034

Figure A1—Control Drawing Configuration (Drawing No. 420031)

NOTES:

1. SUITABLE FOR INTRINSICALLY SAFE INSTALLATION IN CLASS I, DIV. 1, GP. C, D; CLASS I, DIV. 2, GP. A, B, C, D; CLASS II, DIV. 1, GP. E, F & G; CLASS II, DIV. 2, GP. F & G. CLASS III, DIV. 2 HAZARDOUS LOCATIONS. WIRING METHODS SHALL BE INSTALLED IN ACCORDANCE WITH ANS/NFPA 70 (NEC), ANS/NFPA 72 AND ISA RP 12.6.
2. I. S. BARRIERS MUST BE INSTALLED IN ACCORDANCE WITH THE MANUFACTURER'S GUIDELINES.
3. THIS DRAWING SHOWS ONE SENSOR CONNECTED IN A CLASS B, STYLE B CONFIGURATION PER NFPA 72. MULTIPLE SENSORS MAY NOT BE CONNECTED TO THE SAME BARRIER. AN END OF LINE DEVICE (EOL) IS REQUIRED TO MONITOR LINE CONTINUITY.
4. END OF LINE DEVICE VALUE PLUS BARRIER RESISTANCE MUST PROVIDE ADEQUATE SUPERVISION CURRENT FOR FIRE ALARM CONTROL PANEL.
5. RESISTANCE BETWEEN BARRIER GROUND AND EARTH GROUND MUST NOT EXCEED ONE OHM.
6. PM-5MP AND PM-5MP+ INTERCONNECT VIA FLYING LEAD. EXTENSION CABLE SHALL COMPLY WITH ANS/NFPA 70 (NEC) ARTICLE 504-30(b)(2).
7. CABLE SHIELD MUST BE TIED TO INTRINSIC SAFETY GROUND AT THE BARRIER.
8. THE PM-5MP AND PM-5MP+ SENSORS HAVE BEEN SYSTEM APPROVED WITH THE FM APPROVED BARRIERS LISTED IN THE BARRIER TABLE.
9. MAXIMUM CABLE LENGTH: 1000 FEET.

HAZARDOUS LOCATIONS:
 CLASS I, DIV. 1, GP. C, D
 CLASS II, DIV. 1, GP. E, F, G
 CLASS III, DIV. 2

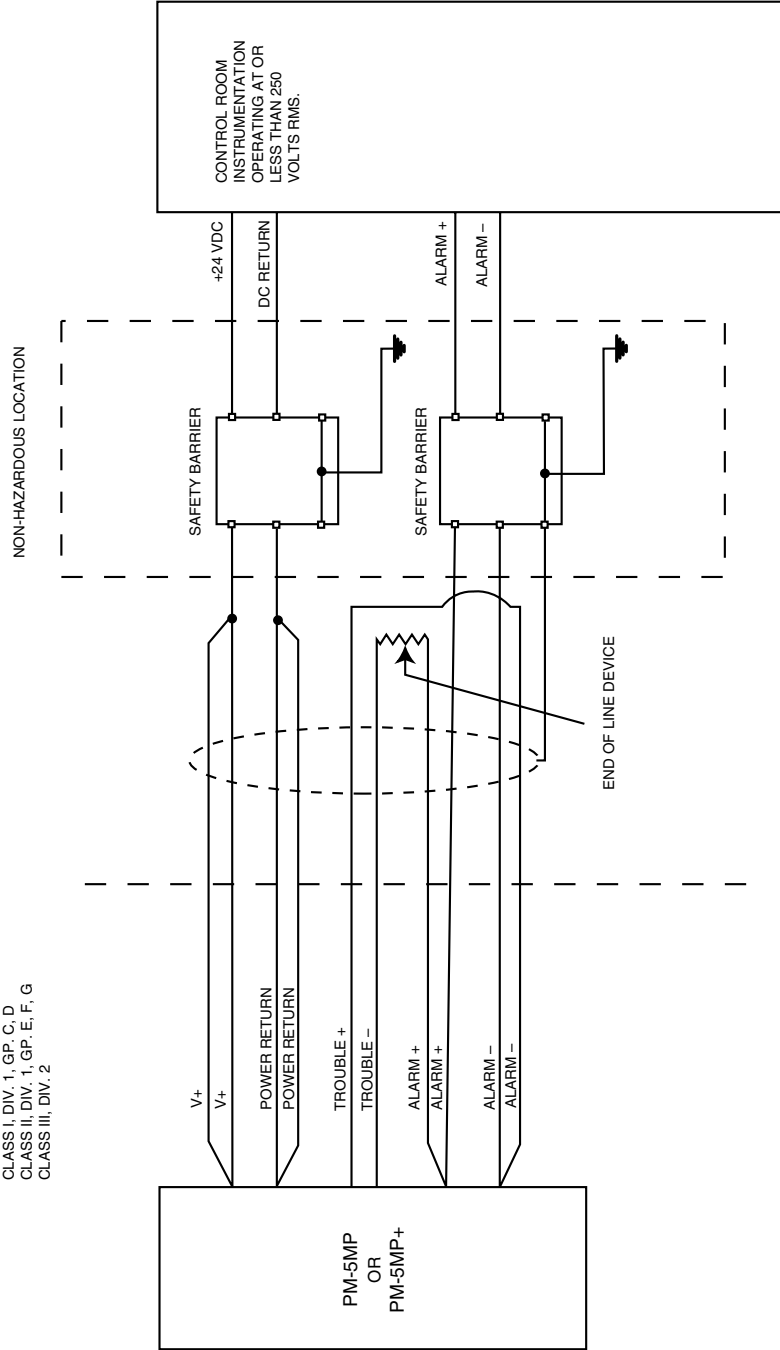

Figure B1—Intrinsically Safe Class B, Style B Wiring (Drawing No. 420032)

APPENDIX B
INTRINSICALLY SAFE
CLASS B, STYLE B WIRING
Hazardous (Classified) Locations:
Class I, Division 1, Group C, D
Class I, Division 2, Group A, B, C, D
Class II, Division 1, Group E, F, G
Class II, Division 2, Group F, G
Class III, Division 2

FIRE SENSOR ELECTRICAL INTERFACE	
Wire Color	Signal
Red	V+, Input Power
Orange	V+, Input Power
Black	Power Return
Brown	Power Return
Yellow	Alarm +
Green	Alarm +
Blue	Alarm -
Violet	Alarm -
Gray	Trouble +
White	Trouble -

BARRIER TABLE

MODEL	MANUFACTURER	BARRIER PARAMETERS	
		Vt (V)	It (mA)
900277-280-094-00	STAHL	28.1	87.0
Z978	PEPPERL + FUCHS	30.0	93.0
7278ac	MTL	28.0	94.0

HAZARDOUS LOCATION:
 CLASS I, DIV. 2, GROUPS A, B, C & D.
 CLASS II, DIV. 2, GROUPS F & G.
 CLASS III, DIV. 1 & 2.

NON-HAZARDOUS LOCATION

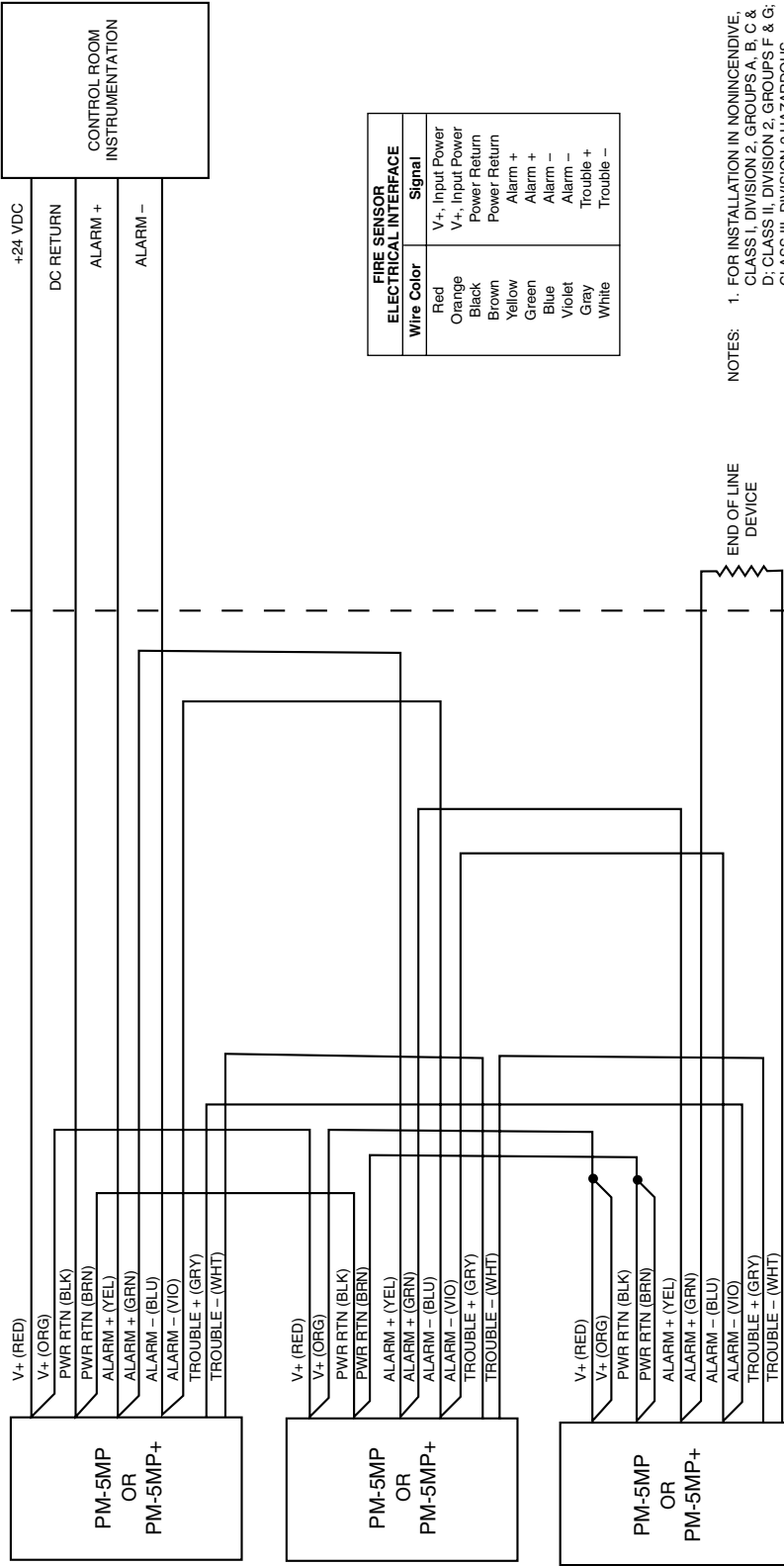

- NOTES:
- FOR INSTALLATION IN NONINCENDIVE, CLASS I, DIVISION 2, GROUPS A, B, C & D; CLASS II, DIVISION 2, GROUPS F & G; CLASS III, DIVISION 2 HAZARDOUS (CLASSIFIED) LOCATIONS, OR NON-HAZARDOUS LOCATIONS ONLY. WIRING METHODS SHALL BE INSTALLED IN ACCORDANCE WITH ANS/NFPA 70 (NEC) ARTICLE 501-4(b) AND ANS/NFPA 72.
 - THIS DRAWING SHOWS THREE SENSORS CONNECTED IN ONE ZONE IN A CLASS B, STYLE B CONFIGURATION PER NFPA 72. ADDITIONAL SENSORS CAN BE ADDED BY REPEATING THE WIRING PATTERN OF THE CENTRAL SENSOR.
 - PM-5MP AND PM-5MP+ INTERCONNECT VIA FLYING LEAD.
 - ELECTRICAL REQUIREMENT: 9 TO 30 VDC AND 10 MILLIAMPS (MAX) PER SENSOR.
 - AN END OF LINE DEVICE, AS REQUIRED BY THE FIRE ALARM CONTROL PANEL, IS USED TO MONITOR LINE CONTINUITY.

Figure C1—Non-Incendive Class B, Style B Wiring (Drawing No. 420033)

APPENDIX C
NONINCENDIVE
CLASS B, STYLE B WIRING
 Hazardous (Classified) Locations:
 Class I, Division 2, Group A, B, C, D
 Class II, Division 2, Group F, G
 Class III, Division 2
 Non-hazardous (Non-classified) Locations

HAZARDOUS LOCATION:
 CLASS I, DIV. 2, GROUPS A, B, C & D.
 CLASS II, DIV. 2, GROUPS F & G.
 CLASS III, DIV 1 & 2.

NON-HAZARDOUS LOCATION

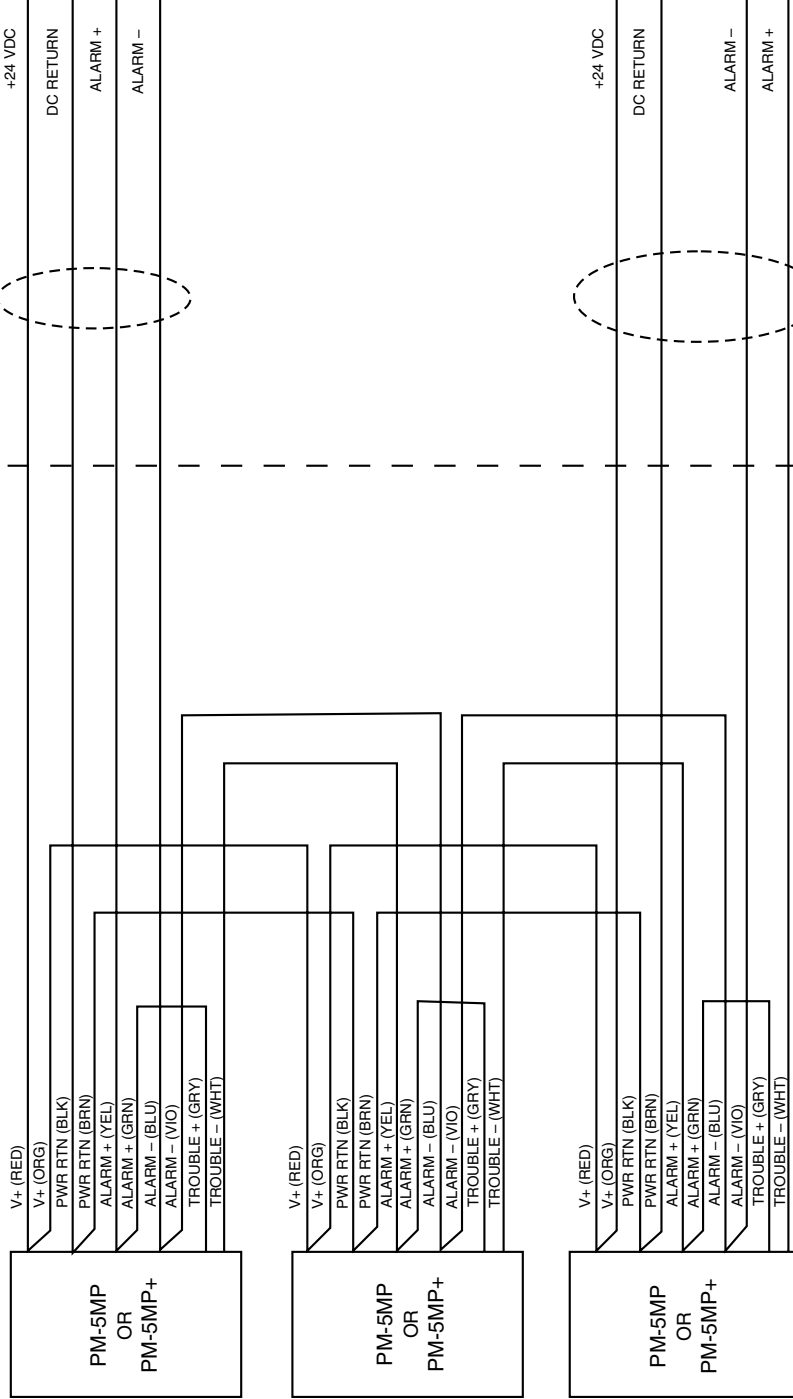

Figure D1—Non-Incendive Class A, Style D Wiring (Drawing No. 420034)

- NOTES:
1. FOR INSTALLATION IN NONINCENDIVE, CLASS I, DIVISION 2, GROUPS A, B, C & D; CLASS II, DIVISION 2, GROUPS F & G; CLASS III, DIVISION 2 HAZARDOUS (CLASSIFIED) LOCATIONS, OR NON-HAZARDOUS LOCATIONS ONLY. WIRING METHODS SHALL BE INSTALLED IN ACCORDANCE WITH ANSI/NFPA 70 (NEC) ARTICLE 501-4(b) AND ANSI/NFPA 72.
 2. THIS DRAWING SHOWS THREE SENSORS CONNECTED IN ONE ZONE IN A CLASS A, STYLE D CONFIGURATION PER NFPA 72. ADDITIONAL SENSORS CAN BE ADDED BY REPEATING THE WIRING PATTERN OF THE CENTRAL SENSOR.
 3. PM-5MP AND PM-5MP+ INTERCONNECT VIA FLYING LEAD.
 4. ELECTRICAL REQUIREMENT: 9 TO 30 VDC AND 10 MILLIAMPS (MAX) PER SENSOR.
 5. THE OUTGOING AND RETURN (REDUNDANT) CIRCUIT CONDUCTORS SHALL NOT BE RUN IN THE SAME CABLE ASSEMBLY, ENCLOSURE, OR RACEWAY PER NFPA 72.

FIRE SENSOR ELECTRICAL INTERFACE	
Wire Color	Signal
Red	V+, Input Power
Orange	V+, Input Power
Black	Power Return
Brown	Power Return
Yellow	Alarm +
Green	Alarm +
Blue	Alarm -
Violet	Alarm -
Gray	Trouble +
White	Trouble -

APPENDIX D

NONINCENDIVE

CLASS A, STYLE D WIRING

Hazardous (Classified) Locations:
 Class I, Division 2, Group A, B, C, D
 Class II, Division 2, Group F, G
 Class III, Division 2

Non-hazardous (Non-classified) Locations

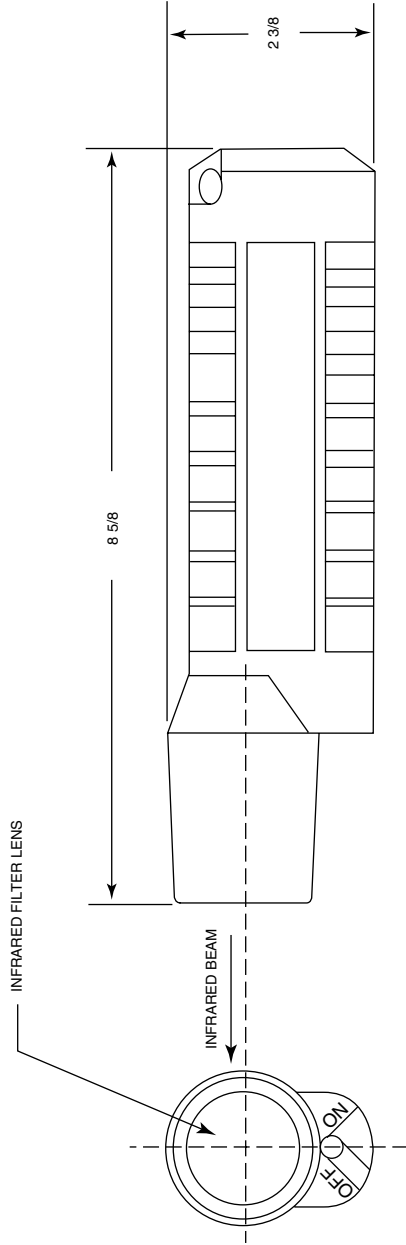
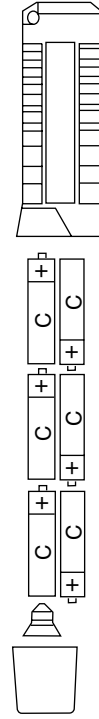

Figure E1—PSS-MP Test Set



- LAMP REPLACEMENT**
 REPLACE XENON LAMP MODULE WITH PN 18801 (UNDERWATER KINETICS).
- WARNING**
 THIS UNIT IS NOT RATED FOR USE IN HAZARDOUS (CLASSIFIED) LOCATIONS.
- CAUTION**
 A FULL SYSTEM TEST RESULTS IN AN ALARM OUTPUT. THIS WILL RESULT IN THE AUTOMATIC SUPPRESSION SYSTEM BEING ACTIVATED IF IT IS NOT DISABLED PRIOR TO TESTING.
- OPERATION**
 TURN ON PSS-MP. WAIT 15 SECONDS. TO CAUSE AN ALARM. HOLD PSS-MP SO THAT THE INFRARED FILTER LENS IS LESS THAN 1 INCH FROM THE FRONT OF THE FLAME DETECTOR TO BE TESTED. IT CAN TAKE SEVERAL SECONDS FOR THE DETECTOR TO ALARM.
- NOTE**
 FOR VALID TEST RESULTS, THE TEST SET AND THE SENSOR UNDER TEST MUST BE AT APPROXIMATELY THE SAME TEMPERATURE.
- BATTERY REPLACEMENT**
 THE TEST SET REQUIRES 6 ALKALINE C-SIZE BATTERIES.
- WARNING**
 CHANGE BATTERY IN NON-HAZARDOUS LOCATION ONLY.

APPENDIX E
PSS-MP TEST SET



Printed in USA

Detector Electronics Corporation
6901 West 110th Street • Minneapolis, Minnesota 55438 USA
Tel: 952.941.5665 or 800.765.3473 • Fax: 952.829.8750