



# INSTRUCTIONS

Eagle 2000™  
Hazard Event Monitoring System



With the trend toward increasingly widespread use of microprocessors and a wide variety of other electrostatic sensitive semiconductor devices, the need for careful handling of equipment containing these devices deserves more attention than it has received in the past.

Electrostatic damage can occur in several ways. The most familiar is by physical contact. Touching an object causes a discharge of electrostatic energy that has built up on the skin. If the charge is of sufficient magnitude, a spark will also be visible. This voltage is often more than enough to damage some electronic components. Some devices can be damaged without any physical contact. Exposure to an electric field can cause damage if the electric field exceeds the dielectric breakdown voltage of the capacitive elements within the device.

In some cases, permanent damage is instantaneous and an immediate malfunction is realized. Often, however, the symptoms are not immediately observed. Performance may be marginal or even seemingly normal for an indefinite period of time, followed by a sudden and mysterious failure.

Damage caused by electrostatic discharge can be virtually eliminated if the equipment is handled only in a static safeguarded work area and if it is transported in a package or container that will render the necessary protection against static electricity.

Det-Tronics modules that might be damaged by static electricity are carefully wrapped in a static protective material before being packaged. Foam packaging blocks are also treated with an antistatic agent.

If it should ever become necessary to return the module, it is highly recommended that it be carefully packaged in the original carton **and static protective wrapping**.

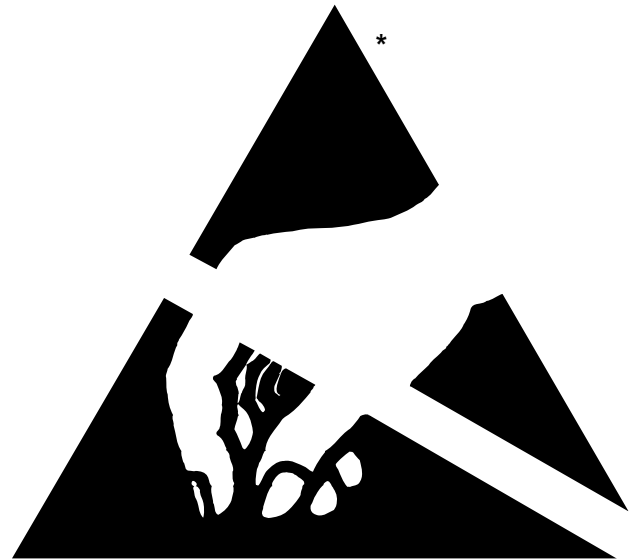

Since a static safeguarded work area is usually impractical in most field installations, caution should be exercised to handle the module by its metal shields, taking care not to touch electronic components or terminals.

In general, always exercise all of the accepted and proven precautions that are normally observed when handling electrostatic sensitive devices.

A warning label is placed on the packaging, identifying those units that use electrostatic sensitive semiconductor devices.

\*Published in accordance with EIA Standard 471

# Table of Contents

## SECTION I SYSTEM OVERVIEW

|   |   |
|---|---|
| APPLICATION .....                                   | 1 |
| FEATURES .....                                      | 1 |
| SYSTEM DESCRIPTION .....                            | 1 |
| Detector .....                                      | 1 |
| Communication Gateway – EA2100CG .....              | 2 |
| Communication Module – EA2300CM .....               | 2 |
| Digital Communication Unit – EA2200DCU .....        | 2 |
| Network Extender – EA2400NE .....                   | 3 |
| Relay Module – EA2500RM .....                       | 3 |
| NETWORK OPERATION DURING A FAULT<br>CONDITION ..... | 3 |

## SECTION II EA2300CM COMMUNICATION MODULE

|                              |   |
|------------------------------|---|
| APPLICATION .....            | 4 |
| FEATURES .....               | 4 |
| SPECIFICATIONS .....         | 4 |
| DESCRIPTION .....            | 5 |
| Addressability .....         | 5 |
| Status LED's .....           | 5 |
| Outputs .....                | 6 |
| Inputs .....                 | 6 |
| Reed Switch .....            | 6 |
| Event Logging .....          | 6 |
| Fault Tolerant Network ..... | 6 |
| Enclosure .....              | 6 |
| Terminal Wiring Board .....  | 6 |

## SECTION III EA2200DCU DIGITAL COMMUNICATION UNIT

|                          |   |
|--------------------------|---|
| APPLICATION .....        | 7 |
| FEATURES .....           | 7 |
| SPECIFICATIONS .....     | 7 |
| DESCRIPTION .....        | 8 |
| Enclosure .....          | 8 |
| DCU Circuit Boards ..... | 8 |

## SECTION IV EA2100CG COMMUNICATION GATEWAY

|                      |   |
|----------------------|---|
| APPLICATION .....    | 9 |
| FEATURES .....       | 9 |
| SPECIFICATIONS ..... | 9 |
| DESCRIPTION .....    | 9 |
| Main Gateway .....   | 9 |

|                                    |    |
|------------------------------------|----|
| Auxiliary Gateway .....            | 10 |
| Faceplate Description .....        | 10 |
| LEDs .....                         | 11 |
| Relays .....                       | 11 |
| Automatic Diagnostics .....        | 11 |
| Fault Tolerant Communication ..... | 12 |
| System Capacity .....              | 12 |
| Installation .....                 | 12 |

## SECTION V EA2400NE NETWORK EXTENDER

|  |    |
|--|----|
| APPLICATION .....                      | 12 |
| FEATURES .....                         | 12 |
| SPECIFICATIONS .....                   | 12 |
| DESCRIPTION .....                      | 13 |
| Automatic Diagnostics .....            | 13 |
| Enclosure .....                        | 13 |
| GENERAL INFORMATION .....              | 13 |
| System Capacity .....                  | 13 |
| Temperature Limitations .....          | 13 |
| Response Time Versus System Size ..... | 14 |

## SECTION VI EA2500RM RELAY MODULE

|                                      |    |
|--------------------------------------|----|
| APPLICATION .....                    | 14 |
| FEATURES .....                       | 14 |
| SPECIFICATIONS .....                 | 14 |
| DESCRIPTION .....                    | 15 |
| Conditions for Relay Actuation ..... | 15 |
| Operating Modes .....                | 15 |
| Inputs .....                         | 15 |
| Outputs .....                        | 15 |
| Status Update .....                  | 15 |
| Addressability .....                 | 16 |
| Event Logging .....                  | 16 |
| Status LEDs .....                    | 16 |
| Fault Tolerant Network .....         | 16 |
| Wiring .....                         | 16 |
| Enclosure .....                      | 16 |

## SECTION VII SYSTEM INSTALLATION

|   |    |
|---|----|
| GENERAL WIRING REQUIREMENTS .....         | 16 |
| DETERMINING GAUGE OF POWER WIRING .....   | 17 |
| COMMUNICATION MODULE AND DCU WIRING ..... | 19 |
| TYPICAL APPLICATIONS .....                | 19 |
| GATEWAY WIRING .....                      | 20 |
| Gateway Switch Settings .....             | 20 |
| INSTALLATION CHECKLIST .....              | 27 |

## SECTION VIII SYSTEM STARTUP

|   |    |
|---|----|
| STARTUP PROCEDURE .....   | 28 |
| SYSTEM CONFIGURATION .....  | 28 |
| CALIBRATION .....   | 28 |
| CALIBRATION ALGORITHMS .....  | 28 |
| Calibration Algorithm A (Type Codes 1, 2, 3, 4)<br>for Gas Detectors .....          | 29 |
| Calibration Algorithm A (Type Codes 1, 2, 3, 4)<br>for Environmental Monitors ..... | 30 |
| Calibration Algorithm B (Type Codes 5, 6) .....                                     | 31 |
| Calibration Algorithm C (Type Codes 7, 8, 9, 10) .....                              | 32 |
| Calibration Algorithm D (Type Codes 11, 12, 13, 14) .....                           | 33 |
| Calibration Algorithm E (Type Codes 23 and 24) .....                                | 34 |
| Calibration Algorithm F (Type Codes 15 to 22) .....                                 | 34 |

## SECTION IX SYSTEM MAINTENANCE

|                                      |    |
|--------------------------------------|----|
| ROUTINE MAINTENANCE .....            | 35 |
| Manual Check of Output Devices ..... | 35 |
| Checkout in Normal Mode .....        | 35 |
| O-Ring Maintenance .....             | 35 |
| Sensor Replacement .....             | 36 |
| REPLACEMENT PARTS .....              | 36 |
| DEVICE REPAIR AND RETURN .....       | 36 |
| Office Locations .....               | 36 |
| ORDERING INFORMATION .....           | 38 |
| Mounting Racks .....                 | 38 |
| Accessories .....                    | 38 |
| Replacement Parts .....              | 38 |
| REFERENCE LIST .....                 | 38 |

### List of Illustrations

|           |  |    |
|-----------|--|----|
| Figure 1  | Simplified Eagle System .....  | 2  |
| Figure 2  | Normal Communication over the Digital Highway .....  | 3  |
| Figure 3  | Communication with a Single Wiring Fault on the Network .....                                | 3  |
| Figure 4  | Communication with Multiple Wiring Faults on the Network .....                               | 4  |
| Figure 5  | Network Wiring Fault Affects Communication with Relay Module and Auxiliary Gateway .....     | 4  |
| Figure 6  | Dimensions of Communication Module and Relay Module Enclosures in Inches (Centimeters) ..... | 5  |
| Figure 7  | Terminal Wiring Board Installed in Junction Box .....  | 7  |
| Figure 8  | Dimensions of DCU and Network Extender Enclosures in Inches (Centimeters) .....              | 8  |
| Figure 9  | Gateway Dimensions in Inches (Centimeters) .....   | 9  |
| Figure 10 | Gateway Faceplate .....  | 10 |
| Figure 11 | Gateway Multiplexing .....   | 12 |

|           |   |    |
|-----------|---|----|
| Figure 12 | Basic Eagle System with One Gateway .....   | 13 |
| Figure 13 | Expanded System with Two Network Extenders .....  | 14 |
| Figure 14 | Eagle System with Two Gateways .....  | 14 |
| Figure 15 | Recommended Grounding for Cable Shields .....   | 17 |
| Figure 16 | Wiring Configuration for Communication Module and DCU .....   | 19 |
| Figure 17 | Communication Module Address Switches .....   | 19 |
| Figure 18 | A Typical Application – Communication Module with an Eagle U8700 or U8800 Detector .....                  | 20 |
| Figure 19 | A Typical Application – Communication Modules or DCUs with Toxic Gas Sensors .....                        | 21 |
| Figure 20 | A Typical Application – Communication Modules or DCUs with Combustible Gas Sensors and Transmitters ..... | 22 |
| Figure 21 | A Typical Application – Communication Modules with Flame Detection Devices .....                          | 23 |
| Figure 22 | Dimensions of Q4004 Mounting Rack .....   | 24 |
| Figure 23 | Clip Positioning for Q4004 Mounting Racks .....   | 24 |
| Figure 24 | Gateway Terminal Configuration .....  | 25 |
| Figure 25 | A Typical Eagle System with Gateway, Communication Modules and OIS .....                                  | 25 |
| Figure 26 | A Typical Eagle System with Gateway, Communication Module, Network Extender and Relay Module .....        | 26 |
| Figure 27 | Gateway DIP Switch Assignments .....  | 27 |
| Figure 28 | Gateway DIP Switch Location .....   | 27 |
| Figure 29 | Calibration Algorithms “A” and “F” .....  | 29 |
| Figure 30 | Calibration Algorithm “B” .....   | 31 |
| Figure 31 | Calibration Algorithm “C” .....   | 32 |
| Figure 32 | Calibration Algorithm “D” .....   | 34 |
| Figure 33 | Calibration Algorithm “E” .....   | 34 |

### List of Tables

|         |  |    |
|---------|--|----|
| Table 1 | Detector Type Codes .....                                | 11 |
| Table 2 | Detector Range Codes .....                               | 11 |
| Table 3 | Fault Codes .....  | 11 |
| Table 4 | Status Conditions Capable of Actuating Relay .....       | 15 |
| Table 5 | Typical Resistance of Stranded Copper Wire at 75°C ..... | 17 |
| Table 6 | Baud Rate Selection – Switches S6-1, S6-2, S6-3 .....    | 27 |
| Table 7 | Gateway Address – Switches S8-1, S8-2 .....              | 27 |

## Hazard Event Monitoring System

### Section I System Overview

#### NOTE

*This manual covers the basic operation of the communication module, digital communication unit, gateway, network extender and relay module. It will not cover any specific detector, host device or Operator Interface Station. Refer to the appropriate instruction manual for complete information relating to these devices. While this manual covers general practices and procedures for installation and wiring of the Eagle 2000 system, always refer to the instruction manual provided with each device for specific instructions.*

#### APPLICATION

Det-Tronics' Eagle 2000 is a state-of-the-art hazard detection monitoring system consisting of any combination of addressable flame, gas or environmental detectors. The system communicates through an RS422 or RS232 serial port utilizing Modbus® protocol to make the system's data available to a variety of host devices.

#### FEATURES

- Field addressable
- Utilizes industry standard Modbus protocol
- Comprehensive data acquisition
- Up to 250 devices per loop on a single twisted pair of wires
- Accommodates a variety of devices with 4 to 20 ma or relay contact inputs
- Non-volatile memory for alarm and calibration data
- Fault tolerant communication loop
- Built in diagnostics
- Compatible with Det-Tronics flame, gas or environmental sensors
- Sensor sensitivity trending.

Modbus is a registered trademark of Modicon Inc.



#### SYSTEM DESCRIPTION

The Eagle system can consist of the following components:

- Detector
- Communication Gateway (EA2100CG)
- Digital Communication Unit (EA2200DCU)
- Communication Module (EA2300CM)
- Network Extender (EA2400NE)
- Relay Module (EA2500RM)
- A host device

Shielded twisted pair cable (22 AWG, Level 4) is used to wire all nodes in a serial communication loop starting and ending at the gateway. Refer to Figure 1.

#### DETECTOR

The Eagle system is compatible with a variety of detectors including flame, combustible gas, toxic gas, oxygen, and environmental monitoring devices. The output of the detector can be a 4 to 20 ma signal, or a digital contact signal such as a switch closure or relay contact.

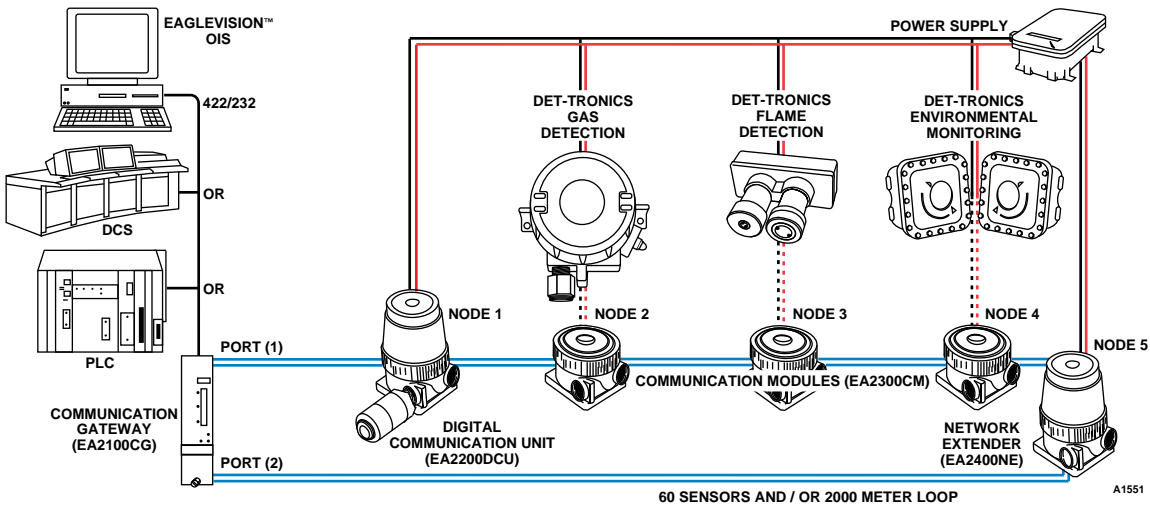

Figure 1—Simplified Eagle System

### COMMUNICATION GATEWAY – EA2100CG

The gateway provides the communication link between the communication module/detector and a Det-Tronics Operator Interface Station, programmable logic controller (PLC), distributed control system (DCS) or other host device. Registers in the gateway are used for passing information between the gateway and the host or between the gateway and nodes on the network. The gateway communicates through an RS232 or RS422 serial port using Modbus protocol.

Local annunciation capability is provided using LEDs, a three digit display, and a twenty segment bar graph display on the faceplate of the gateway. The LEDs indicate normal operation, alarm, calibration or fault condition. When an alarm condition occurs at a node on the network or when a calibration or fault event occurs, the address and type of detector are identified on the digital display, and the percentage of full scale is indicated on the bar graph. If a single event occurs, the gateway display shows the pertinent information for the detector at that specific address. If more than one event should occur at the same time, the display will sequentially show each detector's information by order of address.

Five relays are also provided – four fully configurable alarm relays and one fault relay.

The use of additional gateways (each with its own host connection) is possible, thereby ensuring enhanced system fault tolerance.

The communication gateway is a rack mountable device that occupies two spaces in a standard Det-Tronics mounting rack (in control room location).

Refer to Section IV of this manual for a complete description of gateway operation.

### COMMUNICATION MODULE – EA2300CM

Each detector on the loop has its own communication module. The communication module enables a conventional detector to be converted to an addressable detector. It provides communication capability for the detector by digitizing a 4 to 20 ma output and transmitting the value as a process variable to the gateway. The communication module can also accept two digital contact inputs. In addition, the communication module sends status and diagnostic information for itself and its detector to the gateway.

The communication module consists of an electronic printed circuit board incorporating state-of-the-art communication technology, mounted inside a watertight, explosion-proof aluminum junction box. It is designed for use in hazardous locations and is typically mounted at or near the point of detection.

DIP switches on the communication module circuit board are used to set the address of the communication module, enabling the communication gateway to identify each individual detector in the system.

Refer to Section II of this manual for a complete description of communication module operation.

### DIGITAL COMMUNICATION UNIT – EA2200DCU

The Digital Communication Unit (DCU) digitizes a 4 to 20 ma analog signal from a sensor/transmitter and transmits the value as a process variable to the gateway. The DCU consists of an aluminum enclosure containing a communication module circuit board and a terminal wiring board. The communication module circuit board is identical to the circuit board used in the communication module described above. The DCU enables the use of Det-Tronics basic sensor/transmitters, which attach directly to the DCU enclosure, and provides a means of performing non-intru-

sive calibration. Unlike the communication module, the DCU allows the operator to view three status indicating LEDs through a viewing window on the enclosure cover.

The DCU is available in three different models to allow use with a variety of sensing devices.

Refer to Section III of this manual for a complete description of DCU operation.

### NETWORK EXTENDER – EA2400NE

The EA2400NE Network Extender expands the capabilities of the Eagle system by allowing additional nodes as well as additional wiring to be added to the communication loop. Without a network extender, the communication network is limited to 60 nodes on a 2000 meter loop. Each network extender, however, increases the capacity of the loop by up to 60 nodes and 2000 meters of wiring, up to a maximum of 250 nodes and 10,000 meters of wiring.

The electronic circuitry is mounted inside an explosion-proof metal housing for installation in hazardous locations.

Refer to Section V of this manual for a complete description of network extender operation.

### RELAY MODULE – EA2500RM

The Eagle Relay Module monitors a selected group of detection nodes on the digital communication loop. The relay module is furnished with a sealed SPDT relay and generates an output when the selected criteria for output actuation are met.

The specific status conditions to which the relay module will respond are selected at the time of configuration. These can include one or more of a variety of fault, alarm or calibration events.

The relay module must be configured to operate in either the common alarm mode or the voting mode. When configured to operate as a common alarm, the relay is actuated when an event specified for output actuation occurs at any of the nodes within the specified block of addresses on the loop. Alternatively, the relay module can perform a voting function, monitoring up to 8 detection nodes in a zone and actuating its relay when an event specified for output actuation occurs at a minimum number of nodes within the zone (selectable from 1 to 8).

All electronic circuitry is contained inside a watertight, explosion-proof aluminum enclosure that is designed for installation in hazardous locations.

Refer to Section VI of this manual for a complete description of relay module operation.

## NETWORK OPERATION DURING A FAULT CONDITION

The Eagle system utilizes a unique method for detecting an open or short in the communication network wiring. This state-of-the-art feature minimizes the possibility of a communication breakdown in the event of a wiring fault in the communication loop and can also serve as an aid in troubleshooting.

The communication network is constructed as a loop that starts and ends at a pair of ports on the main gateway. The nodes communicate with the main gateway over the digital highway (Figure 2). Communication between the gateway and the communication modules normally occurs through the first gateway port.

Each communication module contains both the hardware and software necessary to isolate it in the event of a wiring fault. If a short occurs somewhere in the network wiring, the gateway annunciates the fault, while the fault isolation circuitry in the communication modules isolates the section of the network where the fault has occurred. Normal communication continues over the network utilizing the second network communication port of the gateway (Figure 3).

A single open or short on the digital highway will not affect normal system communication between the communication modules and the main gateway, since communication is re-established with the gateway from the other direction utilizing the second network communication port. Normal system communication will continue until the wiring problem can be repaired. However, two exceptions must be noted:

1. Multiple wiring faults
2. Communication involving devices other than communication modules.

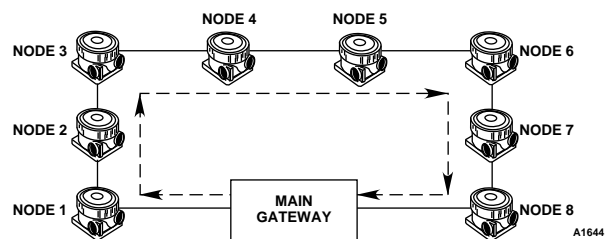

Figure 2—Normal Communication over the Digital Highway

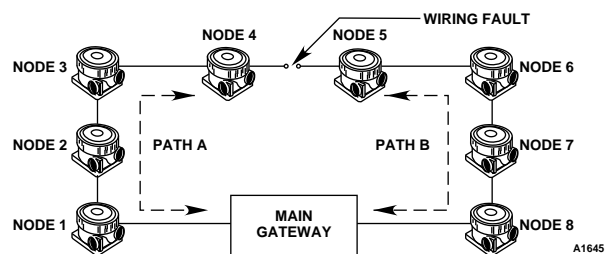

Figure 3—Communication with a Single Wiring Fault on the Network

## Multiple Wiring Faults

In the event of multiple wiring faults, the nodes between the faults will continue to function, but the faults will prevent them from communicating with the main gateway (Figure 4). In this example, nodes 1 to 4 communicate using one gateway port (path A) and nodes 7 and 8 use the other gateway port (path B). Nodes 5 and 6 are unable to report to the gateway because they are isolated by the two wiring faults.

## Communication with Relay Modules or Auxiliary Gateways

It is important to note that data will not “pass through” the main gateway. This means that when a network wiring fault condition exists, devices communicating on one side of the main gateway cannot communicate with devices on the other side of the gateway (Figure 5). In this example, devices communicating along path A cannot communicate with devices using path B.

In the event of a single wiring fault, normal communication will continue between all communication modules and the main gateway. However, if the system uses a relay module (Figure 5) and it is configured to monitor nodes on the other side of the fault, those devices will be unable to report to the relay module. For example, only nodes 4 to 6 (Figure 5) are able to communicate with the relay module. The relay module cannot receive data from nodes 1 to 3. In the same way, only nodes 1 to 3 will be able to communicate with the Auxiliary gateway.

### IMPORTANT

*Since it is impossible to predict where a network fault might occur or exactly what effect it will have on actual system operation, it is important to diagnose and repair any fault as soon as possible after it is detected to ensure reliable system operation.*

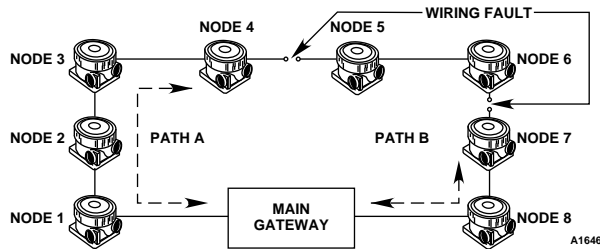

Figure 4—Communication with Multiple Wiring Faults on the Network

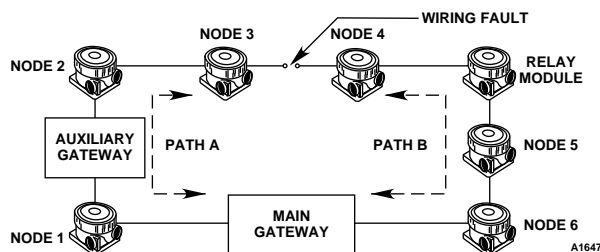

Figure 5—Network Wiring Fault Affects Communication with Relay Module and Auxiliary Gateway

# Section II EA2300CM Communication Module

## APPLICATION

The Eagle Communication Module provides communication capability for a sensing or control device capable of generating a 4 to 20 ma signal. In addition to the 4 to 20 ma input, the communication module can also simultaneously accept two digital contact inputs. Designed for use with the Eagle communication gateway, the communication module provides a unique technique for detecting and isolating opens or shorts in the field wiring. This fault isolation method allows for communication integrity in the event of a single break or short on the communication loop. The communication module circuitry is mounted inside an explosion-proof metal housing, which is typically mounted beside the associated sensing or control device.

The Eagle communication module is compatible with most Det-Tronics flame detection, gas detection or environmental monitoring devices.

## FEATURES

- Field addressable
- Fault isolation
- Pass through communication circuitry on power loss
- 4 to 20 ma analog input
- Two digital contact inputs
- Non-volatile memory for logging of alarm and calibration events
- Sealed 5 ampere SPDT relay
- 2 adjustable alarm setpoints
- 10 bit signal resolution
- EMI hardened
- Screw terminal connectors

## SPECIFICATIONS

INPUT VOLTAGE—  
18 to 32 vdc.

### INPUTS—

4 to 20 ma analog signal, with an input impedance of 200 ohms in series with a protection diode. Two digital inputs (for switch or relay contacts). One is dedicated to either detector calibration or detector fault indication (refer to the System Configuration Matrix, form 95-8453). The other is available for general use, with either a normal or inverted input.



## OUTPUTS—

Digital communication, transformer isolated (78.5 Kbps). Calibrated 0 to 4095 digital output corresponds to 0 to full scale current input from transmitter. Twelve discrete points of status and diagnostic information are also sent to the gateway. One SPDT sealed relay, rated 5 amperes resistive at 30 vdc, is used for remote annunciation, response or reset of external devices.

## POWER CONSUMPTION—

60 ma maximum during normal operation with relay energized or during startup (does not include detector/transmitter power).

## TEMPERATURE RANGE—

Operating: -40°F to +167°F (-40°C to +75°C).  
Storage: -67°F to +185°F (-55°C to +85°C).

## SHIPPING WEIGHT (Approximate)—

2.2 lb (1.0 kg).

## DIMENSIONS—

See Figure 6.

## DESCRIPTION

The Eagle Communication Module consists of a terminal wiring board and a printed circuit board containing the communication circuitry, mounted inside a water-tight, explosion-proof aluminum junction box.

## ADDRESSABILITY

Module identification (up to 250 nodes) is accomplished by setting switches on an eight position DIP switch located on the communication module circuit board.

## STATUS LEDs

Three LEDs are located at the center of the communication module circuit board. (The cover must be removed from the junction box in order to view the LEDs.)

The green LED serves as a power-on indicator and is illuminated whenever power is applied. During normal operation, only the green LED is on.

The red LED is used to indicate a calibration, power-up, fault or alarm condition. The flashing rate of the red LED indicates the following conditions:

|             |   |                                    |
|-------------|---|------------------------------------|
| Power-up    | = | Pulsed at a 0.5 Hz rate            |
| Calibration | = | Pulsed at a 1 Hz rate or on steady |
| Fault       | = | Pulsed at a 4 Hz rate              |
| Alarm       | = | Illuminated continuously.          |

The red LED indicates the various steps of the calibration process. When the calibration begins, the red LED flashes at a 1 Hz rate. When the zero part of the calibration is completed, the LED is on steady. The span gas is then applied to the sensor, the sensor input increases, and the LED flashes at a 1 Hz rate. When the span part of the calibration is completed, the LED is again on steady. When the calibration gas is removed and the sensor signal returns to below 4%, the calibration is complete and the LED turns off.

When power is applied to the system, the red LED flashes at a 1/2 Hz rate until the sensor signal is within 4% of full scale for 10 seconds or 5 minutes has elapsed, whichever comes first.

If the communication module has not been configured, the red LED blinks at the 4 Hz rate.

The amber LED comes on when the service switch is pressed. (Pressing the service switch will not affect normal operation.) The amber LED is provided for factory diagnostic purposes and is not for use in the field. Illumination of the amber LED normally indicates a failure in the communication chip. Replacement of the communication module circuit board is required.

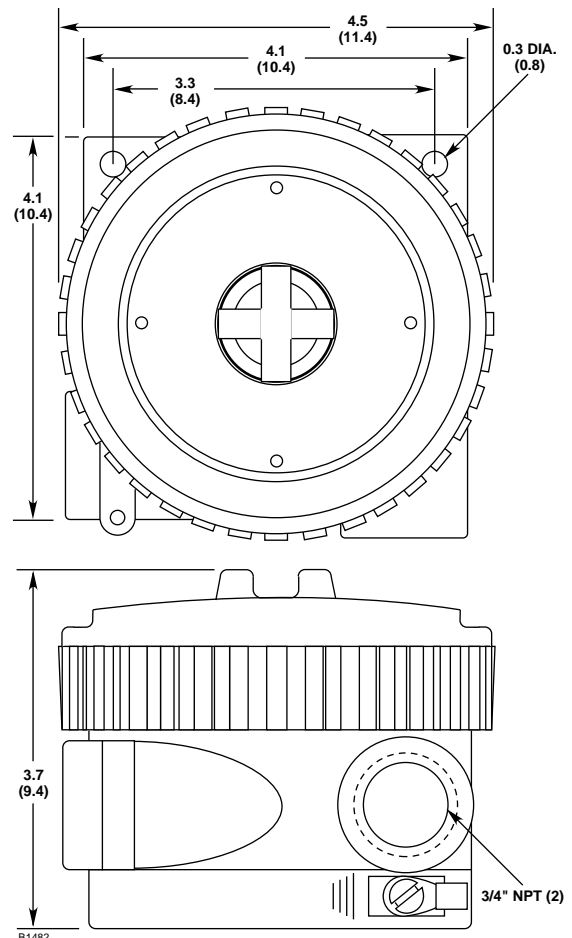

Figure 6—Dimensions of Communication Module and Relay Module Enclosure in Inches (Centimeters)

## OUTPUTS

A 5 ampere SPDT relay is provided. When the communication module is used with a U8700 or U8800, the relay output is used to reset the transmitter. The relay is actuated for 1 second when a "reset sensor" signal is sent to the communication module by the gateway in response to a request from the host.

If the communication module is used with a different sensor/transmitter, the relay is activated when the "alarm 1" threshold is reached. The communication module alarm relay is latching and is reset by a command from the host through the gateway or by cycling power.

The alarm relay is reset by setting the reset sensor bit in the communication module control word. If the process variable is still above the alarm threshold, the relay will not be reset.

## INPUTS

The communication module has one 4 to 20 ma non-isolated input, with an input impedance of 200 ohms in series with a protection diode. A 10 bit analog-to-digital (A/D) converter digitizes the analog signal.

In addition to the 4 to 20 ma analog input, the communication module has two digital inputs. Depending on the type of detector being used, digital input 1 is dedicated to either detector calibration or detector fault indication. (Refer to the System Configuration Matrix, form number 95-8453, to determine the function of input 1 for a specific detector.)

When the communication module is used with a U8700 or U8800 Transmitter, the first digital input is connected to the transmitter calibration relay contacts. The transmitter then uses this relay to signal calibration information to the communication module.

The second digital input is typically used as a simple switch input. The status of this input is reflected in the communication module status word. This input can be configured as a normal or inverted input.

## REED SWITCH

A reed switch, located on the terminal board, enables calibration of the sensor without opening the enclosure. The switch is activated by placing a magnetic calibration tool on a specified location on the side of the enclosure (midway between the two mounting holes, about an inch from the mounting surface).

## EVENT LOGGING

The communication module is capable of logging up to 8 calibration events and 8 alarm events. Date and time stamping of these events is also provided.

## Calibration Log

A log is kept for each calibration. This information can be used by the operator to evaluate the remaining life of a sensor. An aborted calibration is indicated by zeros in the zero and span values. The calibration log is cleared when the sensor replacement switch is pressed and the calibration is successfully completed.

The initial calibration is logged in position one, where it remains for the life of the sensor. If more than 8 calibrations are performed without the sensor replacement switch being pressed, the newest calibration data will replace the second oldest so that the initial calibration data can be saved. The old calibration data will be lost. This feature enables sensor sensitivity trending to aid in maintenance or troubleshooting.

## Alarm Log

A log of alarm 1 and alarm 2 events is stored in each communication module. Time, date and alarm type are logged for each alarm event. A maximum of 8 events can be stored. If more than 8 events are logged, the oldest event will be overwritten.

## FAULT TOLERANT NETWORK

The Eagle system utilizes a unique technique for detecting an open or short in the network wiring. The communication module contains both the software and hardware necessary to isolate it in the event of a wiring fault. This allows communication to continue in the remainder of the network utilizing the second network communication port of the gateway. Refer to "Network Operation During a Fault Condition" in Section I for complete information.

## ENCLOSURE

The explosion-proof, watertight aluminum enclosure is designed for use in Class I, Division 1, Groups B, C and D hazardous locations.

The enclosure is furnished with two 3/4 inch NPT conduit entries.

## TERMINAL WIRING BOARD

All external wiring is connected to screw terminal connectors on the terminal wiring board located inside the junction box (Figure 7). The communication module circuit board connects to the terminal wiring board with a ribbon connector and is mounted inside the junction box above the terminal wiring board.

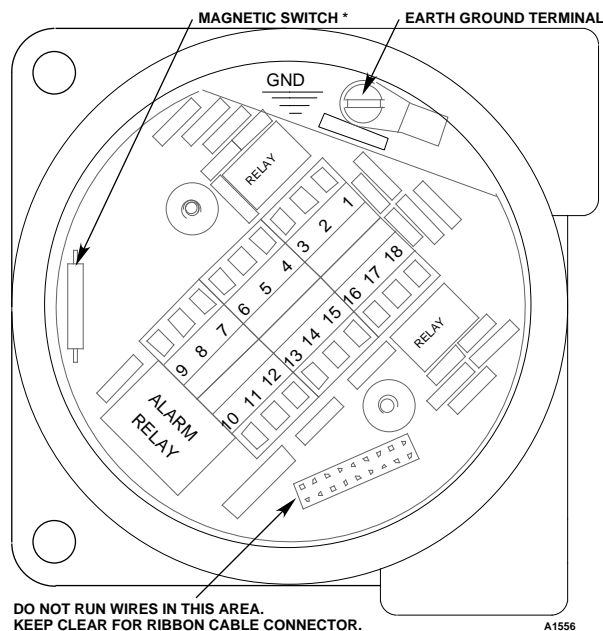

\* TO ACTIVATE THE REED SWITCH, HOLD THE MAGNETIC CALIBRATION TOOL AGAINST THE SIDE OF THE ENCLOSURE MIDWAY BETWEEN THE TWO MOUNTING HOLES, APPROXIMATELY AN INCH ABOVE THE MOUNTING SURFACE FOR COMMUNICATION MODULES, UNIVERSAL DCUs AND COMBUSTIBLE GAS DCUs, AND APPROXIMATELY 3 1/2 INCHES ABOVE THE MOUNTING SURFACE FOR INTRINSICALLY SAFE DCUs.

Figure 7—Terminal Wiring Board Installed in Junction Box

## Section III EA2200DCU Digital Communication Unit

### APPLICATION

The Eagle 2000 Digital Communication Unit (DCU) digitizes a 4 to 20 ma analog signal from a basic Det-Tronics gas sensor/transmitter and transmits the value as a process variable to the Eagle communication gateway. In addition to the 4 to 20 ma input, the DCU can also simultaneously accept two digital (switch or relay contact) inputs. All circuitry is housed in a single explosion-proof/water-tight enclosure for location at the area of detection.

The DCU is provided in various configurations, depending on the type of gas to be detected. (DCUs are available for use with combustible gas, oxygen and toxic gas sensor/transmitters.) All DCUs contain a communications module and a terminal wiring board. DCUs for detecting combustible gas also contain a transmitter board.

### FEATURES

- Field addressable
- Fault isolation
- Pass through communication circuitry on power loss
- 10 bit signal resolution
- 2 alarm setpoints
- Sealed 5 ampere SPDT relay
- Non-volatile memory for logging of alarm and calibration events
- Non-intrusive one person calibration
- LED for calibration, fault and alarm status annunciation
- EMI hardened
- Screw terminal connectors.

### SPECIFICATIONS

#### INPUT VOLTAGE—

18 to 32 vdc.

#### INPUTS—

4 to 20 ma analog signal, with an input impedance of 200 ohms in series with a protection diode. Two digital contact inputs (switch or relay contacts). One is dedicated to detector calibration. The other is available for general use, with either a normal or inverted input.

#### OUTPUTS—

Digital communication, transformer isolated (78.5 kbps). Calibrated 0 to 4095 digital output corresponds to 0 to full scale current input. Twelve discrete points of status and diagnostic information are also sent to the gateway.

One SPDT sealed relay, rated 5 amperes resistive at 30 vdc, is activated when the "alarm 1" threshold is reached. The relay is latching and is reset by the host device when the process variable is below the alarm threshold.

#### POWER CONSUMPTION—

DCU with toxic sensor/transmitter:

95 ma maximum during normal operation with relay energized or during startup.

DCU with transmitter and combustible gas sensor:

180 ma maximum during normal operation with relay energized, 500 ma during startup.

#### TEMPERATURE RANGE—

Operating: -40°F to +167°F (-40°C to +75°C).

Storage: -67°F to +185°F (-55°C to +85°C).

#### SHIPPING WEIGHT (Approximate)—

2.2 lb (1.0 kg).

#### DIMENSIONS—

See Figure 8.

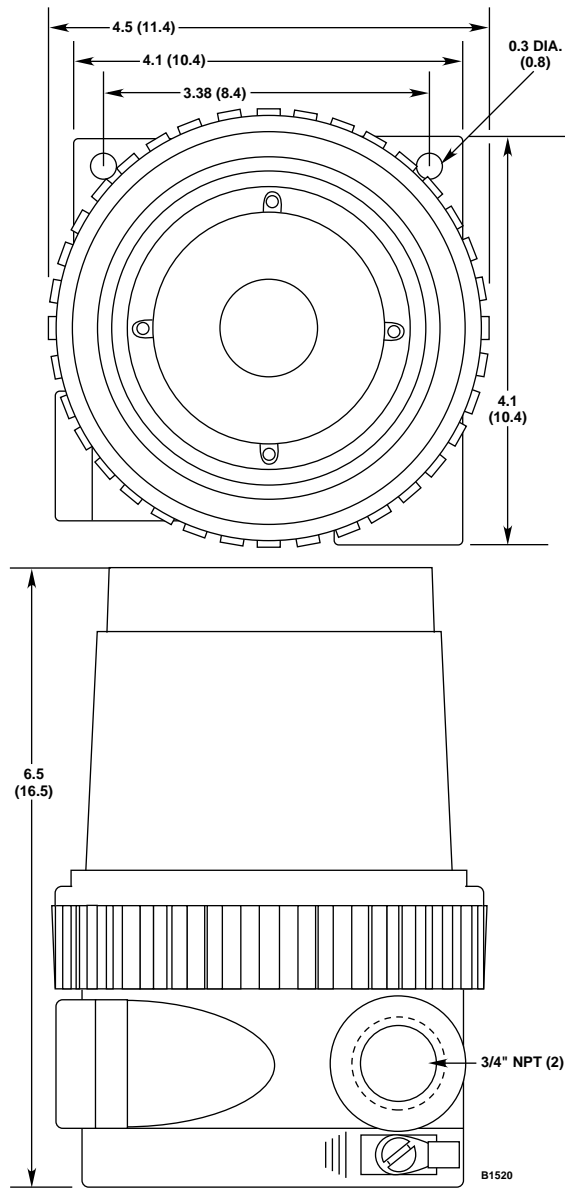

Figure 8—Dimensions of DCU and Network Extender Enclosure in Inches (Centimeters)

## DESCRIPTION

The DCU is available in three different configurations to accommodate a variety of gas sensing devices.

- The combustible gas DCU (EA2200DCU EX) includes a transmitter board for converting the sensor output signal (in millivolts) to a 4 to 20 ma signal for input to the communication module board. The transmitter board is furnished with the test points and controls needed for calibrating the sensor.
- The universal DCU (EA2200DCU UNIV) contains a communication module PC board and a terminal wiring board. This DCU is used with oxygen and toxic gas sensors.
- The intrinsically safe DCU (EA2200DCU IS) is similar to the universal DCU, but includes an intrinsically safe barrier board in addition to the other PC boards. This DCU model is required for use with intrinsically safe sensors.

## ENCLOSURE

The explosion-proof, watertight aluminum enclosure is designed for use in Class I, Division 1, Groups B, C and D hazardous locations. It is designed to meet CENELEC requirements for EEx d IIC T5 hazardous locations, and is IP66 and NEMA 4 rated. The removable cover is furnished with a window to allow the operator to view the three status indicator LEDs on the communication module PC board.

The enclosure is furnished with two 3/4 inch NPT conduit entries.

## DCU CIRCUIT BOARDS

### Terminal Wiring Board

All external wiring is connected to screw terminal connectors on the terminal wiring board located inside the junction box.

### Communication Module Board

The communication module consists of a printed circuit board containing the communication circuitry. The communication module PC board used in the DCU is identical to the PC board used in the EA2300CM Eagle Communication Module.

The communication module provides communication capability for the sensor/transmitter by converting the 4 to 20 ma transmitter output to a 10 bit digital signal and transmitting the value as a process variable to the gateway. It can also accept two digital (contact) inputs. In addition, the communication module sends status and diagnostic information for itself and its sensor to the gateway.

Refer to Section II of this manual for a complete description of the communication module board.

### Transmitter Board

DCUs that are used with combustible gas sensors (EA2200DCU EX) incorporate a transmitter board. This board furnishes operating power for the sensor and converts the sensor output to a 4 to 20 ma signal for input to the communication module board. The transmitter also provides zero and span potentiometers for calibration of the sensor. The DCU is calibrated using the Eagle system calibration algorithm C (algorithm D for oxygen sensors), as described in the "Calibration" section.

### I.S. Barrier Board

Intrinsically safe sensors must be powered through an I.S. barrier, which is included with model EA2200DCU IS.

# Section IV EA2100CG Communication Gateway

## APPLICATION

The gateway provides the communication link between a Det-Tronics addressable detector and the host device. Registers in the gateway are used for passing information between the host and communication modules. The gateway communicates with the host device through a serial interface port (RS232 or RS422) using Modbus protocol.

Local annunciation capability is provided utilizing a three digit display, LEDs and a twenty segment bar graph display. When a detector is in alarm or when a calibration or fault event occurs, the detector's address and detector type are identified on the digital display, and the percentage of full scale is indicated on the bar graph.

## FEATURES

- Utilizes industry standard Modbus protocol
- Bar graph and digital displays
- Alarm, calibrate and fault LEDs
- Transformer isolation of network ports
- Programmable relay outputs
- Mounts in standard Q4004 rack
- Multiple gateways to enhance reliability or support additional host devices
- EMI/RFI hardened.

## SPECIFICATIONS

**INPUT VOLTAGE—**  
18 to 32 vdc.

**POWER CONSUMPTION—**  
Operating: 325 ma at 24 vdc maximum.  
Startup: 1.0 ampere at 24 vdc, momentary.

**I/O PORTS—**  
Host Port: The gateway is a "Modbus slave" device and communicates with a host device through a serial port using Modbus protocol. The serial port provided for the host can be configured as either RS232 or RS422.

Network Port: Two 78.5 kbps communication ports provide the start and end of the loop upon which the sensors and their communication modules reside. The loop wiring is level 4, 22 AWG shielded twisted pair. The wiring is transformer coupled to protect the transceivers.

**TEMPERATURE RANGE—**  
+32°F to +140°F (0°C to +60°C).

**HUMIDITY RANGE—**  
0 to 90% RH, non-condensing.

**SHIPPING WEIGHT (Approximate)—**  
2.6 lb (1.2 kg).

**DIMENSIONS—**  
See Figure 9.

## DESCRIPTION

The Eagle gateway transmits information from the communication modules to any device that can act as a Modbus Master. This interface between the gateway and host device conforms to the Modbus RTU standard.

For systems requiring a higher throughput than the Modbus 19.2 kbaud standard, the EagleVision Operator Interface Station can connect to the gateway at 57.6 kbaud.

The Eagle system is designed to operate with up to 4 gateways (one main and three auxiliary) on a single communication loop. Each gateway is configured by DIP switches to function either as a "main" or an "auxiliary" gateway. Both gateways contain identical software and hardware and differ only in respect to their function within the system.

## MAIN GATEWAY

The main gateway is used by the host device to perform device configuration. It also generates a periodic time and date broadcast as well as a heartbeat signal on the communication loop for use by the devices on the loop in their fault isolation schemes. As long as wiring integrity is maintained, all "normal" gateway initiated communication on the loop originates from the primary communication port (Com. 1). If a fault occurs, communication takes place from both the primary and the secondary communication port (Com. 2).

A relay in the gateway terminates the communication wiring during normal operation. In the event of a power loss, a communication pass-through circuit is created.

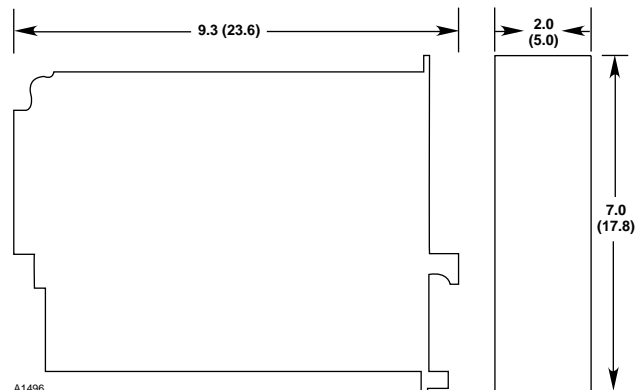

Figure 9—Gateway Dimensions in Inches (Centimeters)

## AUXILIARY GATEWAY

Auxiliary gateways are used to connect additional host devices to the loop for data acquisition purposes. Additional host devices are not able to modify configuration information for the devices on the loop.

During normal operation, the communication relay for the auxiliary gateway is closed, creating a communication pass-through circuit for the communication loop wiring.

Fault isolation is handled by the communication modules on either side of the auxiliary gateway. If power is lost to the gateway, a communication pass-through circuit is created. If an auxiliary gateway does not receive a time and date broadcast or heartbeat signal from the main gateway, its communication relay will open and terminate the loop wiring and it will begin generating the time and date broadcast and heartbeat signal.

Up to three auxiliary gateways can be used in each communication loop. The auxiliary gateway with the lowest address will generate the time and date broadcast and heartbeat signal.

## FACEPLATE DESCRIPTION

The faceplate provides four RELAY LEDs and one FAULT LED, a digital display, a bar graph display, and a reset pushbutton. See Figure 10.

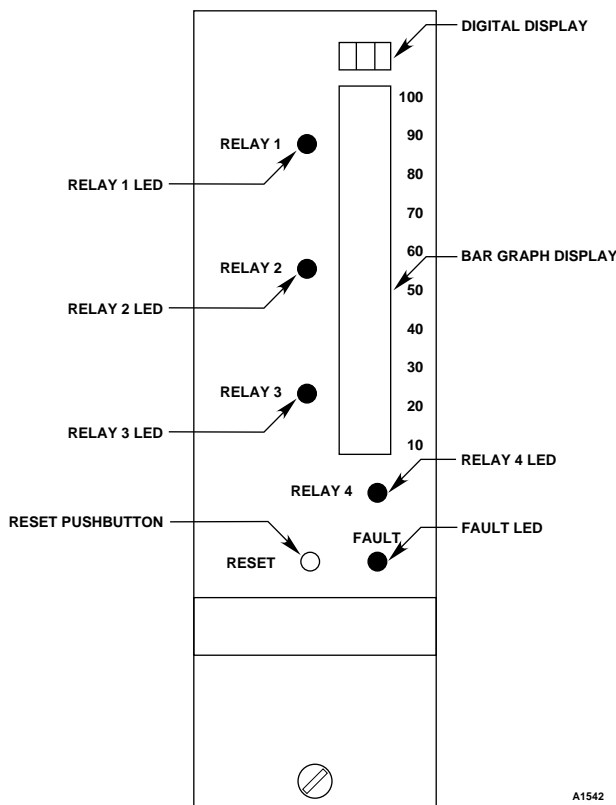

Figure 10—Gateway Faceplate

A1542

## Digital Display

The digital display is a three digit "seven segment" display. During normal operating conditions, the display indicates "000." When a system event occurs (alarm, fault or calibration), the display sequentially shows the detector address, followed by detector type, followed by percent full scale/fault code/calibrate signal.

### IMPORTANT

*The gateway allows simultaneous use of devices with various operating ranges. The gateway display always reads 0 to 100% full scale. If the operating range of the reporting sensor is anything other than 0 to 100 units, the gateway display will indicate a percentage of full scale, not direct engineering units.*

**Detector Address** – All three digits are on and the decimal point for each digit is also on. Up to 250 addresses are available (displayed 0.0.1. to 2.5.0.).

**Detector Type** – The first two digits show the detector type code (Table 1). The third digit displays the detector range code (Table 2).

**Percent/Fault/Calibrate** – The display follows the sensor input in percent of full scale up to 100% full scale. A negative sign is used to indicate a negative zero drift condition.

A fault condition is indicated as "FXX," with F indicating that a fault has occurred and XX identifying the type of fault that is detected (Table 3).

If a detector is being calibrated, the display will show "CAL."

Each indication is shown for 3/4 second, followed by a 1/4 second delay before going to the next indication.

If a single event occurs, the gateway display will lock on that specific address. If more than one event should occur, the digital display and bar graph will track the status of each address where activity is occurring by sequencing through each event by order of address.

## Bar Graph Display

The 20 segment bar graph display tracks the input signal from the sensor, providing a 0 to 100% full scale reading of sensor input.

The bar graph display indicates 0 to 100% full scale, which corresponds to the 4 to 20 ma signal for all gas sensors except oxygen. The 4 to 20 ma signal from an oxygen sensor corresponds to 0 to 25% oxygen.

Table 1—Detector Type Codes

|                             |                    |
|-----------------------------|--------------------|
| <b>GAS</b>                  |                    |
| 01                          | Ex                 |
| 02                          | H <sub>2</sub> S   |
| 03                          | CL <sub>2</sub>    |
| 04                          | CO                 |
| 05                          | NH <sub>2</sub>    |
| 06                          | SO <sub>2</sub>    |
| 07                          | HCL                |
| 08                          | HCN                |
| 18                          | Toxic              |
| 19                          | O <sub>2</sub>     |
| <b>FLAME</b>                |                    |
| 20                          | UV                 |
| 21                          | IR                 |
| 22                          | UV/IR              |
| <b>ENVIRONMENTAL</b>        |                    |
| 40                          | Oil on Water       |
| 41                          | PathWatch Heavy HC |
| 42                          | PathWatch Total HC |
| 43                          | PathWatch Benzene  |
| 44                          | PathWatch Low Sens |
| 60                          | Other              |
| <b>GATEWAY/RELAY MODULE</b> |                    |
| 80                          | Main Gateway       |
| 81                          | Aux Gateway        |
| 82                          | Backway Gateway    |
| 90                          | Relay Module       |

Table 2—Detector Range Codes

| CODE | RANGE      |
|------|------------|
| A    | 0 to 10    |
| C    | 0 to 20    |
| E    | 0 to 25    |
| H    | 0 to 50    |
| J    | 0 to 100   |
| L    | 0 to 200   |
| P    | 0 to 500   |
| U    | 0 to 1000  |
| —    | 4 to 20 ma |

Table 3—Fault Codes

|            |   |
|------------|---|
| <b>F10</b> | = sensor/detector fault (com mod status bits 3 or 12)                       |
| <b>F20</b> | = com mod fault (com mod status bits 1, 2 or 8)                             |
| <b>F30</b> | = network fault detected by gateway<br>(bar graph will show 20 segments on) |
| <b>F31</b> | = loss of power to main gateway<br>(bar graph will show 20 segments on)     |
| <b>F32</b> | = right heartbeat fault   |
| <b>F40</b> | = reset or external reset of gateway<br>held longer than 30 seconds         |
| <b>F50</b> | = gateway communication channel 1 fault                                     |
| <b>F51</b> | = gateway communication channel 2 fault                                     |
| <b>F60</b> | = invalid configuration, unable to configure                                |

## LEDs

Five faceplate LEDs are provided for indicating the status of the gateway relays. The LEDs correspond to the active state of the relay, not the coil condition. When the relay is reset, the corresponding LED is also reset.

## RELAYS

The gateway is provided with five relays. The relays are sealed and have form C (SPDT) contacts rated 5 amperes resistive at 30 vdc/250 vac. The relays can be configured for either normally energized or normally de-energized operation.

Four of the relays are general purpose relays and one functions as a fault relay. The specific function of the four general purpose relays is programmable through the host computer. The fault relay responds to an internal gateway fault or to an open or short condition in the communication network wiring.

Each general purpose relay has three configuration registers. The first designates a starting node address, the second designates an ending node address, and the third is a trigger configuration register.

The starting and ending node address registers designate a "block" of nodes on the network that will activate the corresponding relay when the required conditions are met.

The configuration of the trigger register determines the conditions to which the relay will respond. The gateway will actuate the relay during an event that matches the trigger register parameters and is within the configured block of node addresses. The configurable event options include communication network fault, sensor fault, sensor calibration, alarm, input 2 active and node not communicating.

The relays can be configured for latching or non-latching operation. If latching operation is selected, the relays will remain on until they are reset by pressing the reset push-button on the gateway faceplate, by activating an external reset switch, or by soft command through the gateway control word. The reset function resets the relay, regardless of the status of the initiating device. This allows additional events to trigger the same relay, even though the first device may still be in a triggering mode.

## AUTOMATIC DIAGNOSTICS

The gateway features self-testing circuitry that checks for problems that could prevent proper system response. The gateway performs two forms of diagnostics – self diagnostics and communication loop device diagnostics. Self diagnostic tests monitor the condition

of the gateway and set the fault bit in the gateway status word in the event of a problem. A watchdog timer resets the gateway if its software gets caught in a loop.

In the second form of diagnostics, the gateway provides a watchdog timer for each configured device on the loop. Each time the device reports to the gateway, the timer accumulator is reset to zero and the timer starts over. If a device does not respond before its watchdog timer expires, the gateway sets the "not communicating" bit in the status word for that device.

**CAUTION**

*The fault detection circuitry does not monitor the operation of external response equipment or the wiring to these devices. It is important that these devices be checked periodically to ensure that they are operational.*

**FAULT TOLERANT COMMUNICATION**

Fault tolerance is provided by constructing the communication network as a loop starting and ending at a pair of communication ports on the gateway. Communication between the gateway and the communication modules on the network normally occurs through the first port. If a fault occurs somewhere in the network wiring, the gateway annunciates the fault, while fault isolation circuitry in the communication modules isolates the problem section of the network. Communication is re-established between the gateway and the communication modules downstream of the problem from the other direction utilizing the second network communication port. This feature minimizes the possibility of a communication breakdown in the event of a wiring fault in the communication loop. Refer to "Network Operation During a Fault Condition" in Section I for additional information.

**SYSTEM CAPACITY**

The gateway can support a communication network consisting of up to 60 detectors in a 2000 meter wiring loop. By adding network extenders to the loop, it can be expanded by up to 60 detectors and 2000 meters of wiring per extender, up to a maximum of 250 nodes.

To further expand the system, gateway multiplexing is possible, as illustrated in Figure 11.

Refer to the "Network Extender" section of this manual as well as the network extender instruction manual (form 95-8430) for complete information.

**INSTALLATION**

The Eagle Communication Gateway is rack mountable and occupies two spaces in a standard Det-Tronics Q4004 Mounting Rack (in a non-hazardous area).

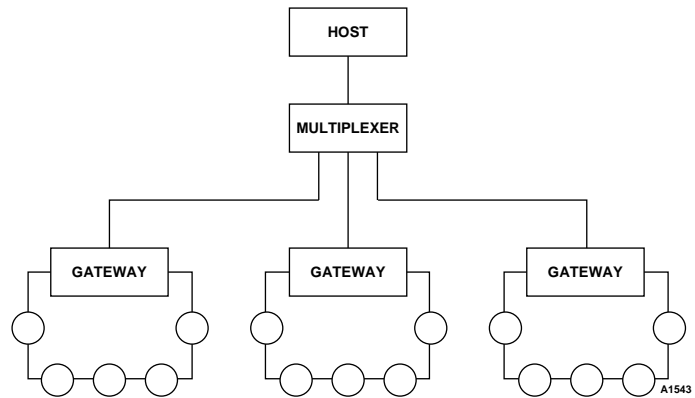

Figure 11—Gateway Multiplexing

**Section V  
EA2400NE  
Network Extender**

**APPLICATION**

The EA2400NE Network Extender expands the capabilities of the Eagle system by allowing additional nodes as well as additional wiring to be added to the communication loop. Without a network extender, the communication network is limited to 60 nodes on a 2000 meter loop. Each network extender, however, increases the capacity of the loop by up to 60 nodes and 2000 meters of wiring, up to a maximum of 250 nodes and 10,000 meters of wiring.

The electronic circuitry is mounted inside an explosion-proof metal housing for installation in hazardous locations.

**FEATURES**

- Increases capacity of total network
- Screw terminal connectors
- Transformer isolation protection.

**SPECIFICATIONS**

**INPUT VOLTAGE—**  
18 to 29 vdc.

**POWER CONSUMPTION—**  
2 watts nominal at 24 vdc, 5 watts maximum.

**INPUTS/OUTPUTS—**  
Digital, transformer isolated (78.5 kbps).

**TEMPERATURE RANGE—**  
Storage: -49°F to +185°F (-45°C to +85°C).  
Operating: Refer to the "System Capacity" section (under General Application Information) for temperature limitations.



**HUMIDITY—**  
0 to 95% RH at 70°C.

**WIRING—**  
The communication network requires 22 AWG level 4 shielded twisted pair wire. Other wiring should be 18 AWG minimum.

**ENCLOSURE RATINGS—**  
Designed to meet FM and CSA requirements for Class I, Division 1, Groups B, C and D; and is NEMA 4 rated. It is designed to meet CENELEC requirements for EEx d IIC T5 hazardous locations, and is IP66 rated.

**SHIPPING WEIGHT (Approximate)—**  
Electronic module: 1.0 lb (0.5 kg)  
Aluminum enclosure: 3.0 lbs (1.4 kg).

**DIMENSIONS—**  
See Figure 8.

## DESCRIPTION

The Eagle Network Extender consists of an electronic module mounted inside a watertight, explosion-proof aluminum enclosure.

Network extender circuitry supports communication in both directions. If the fault detection circuitry in a communication module or DCU isolates a fault in the network, communication can continue in the opposite direction.

The use of a network extender requires no special system configuration at the time of installation, other than the normal configuration of the gateway and communication modules/DCUs.

## AUTOMATIC DIAGNOSTICS

Automatic fault detection circuitry performs a self-test of the network extender's memory upon power-up. Two yellow LEDs, easily visible through the window on the enclosure, are illuminated in the event that a fault is detected. Diagnostic circuitry in the network extender does not monitor system wiring or the functioning of devices connected to the network extender.

## ENCLOSURE

The network extender electronic module is mounted inside an explosion-proof, watertight aluminum enclosure. A mounting bracket is provided inside the enclosure for securing the electronic module. The enclosure has a clear window for easy viewing of the status indicating LEDs. A removable cover allows access to the wiring terminals.

The enclosure is furnished with two 3/4 inch NPT conduit entries.

## GENERAL INFORMATION

### SYSTEM CAPACITY

Eagle system technology allows the main gateway to support a communication loop consisting of up to 60 detection nodes, with up to 2000 meters of connecting wiring. Each network extender that is added to the loop allows it to be expanded by the same amount - up to 60 detectors with an additional 2000 meters of wiring. A single communication loop can accommodate up to 6 network extenders, with a total of no more than 250 nodes and up to 10,000 meters of wiring (Figures 12 and 13).

#### NOTE

*The addition of a second or third gateway to the loop (auxiliary gateway) does not allow additional nodes or wiring to be added to the loop. The use of an auxiliary gateway is intended to allow additional host devices to be connected to the network and/or to provide a backup in the event of a main gateway failure (Figure 14). If the number of detection nodes or the wiring distance of the loop exceeds the limits of the main gateway, one or more network extenders will be required.*

### TEMPERATURE LIMITATIONS

Exposure to extreme operating temperatures reduces the maximum number of nodes allowed on the communication network. If operating temperatures are in the +32°F to +158°F range (0°C to +70°C), the gateway can support up to 60 detectors in a 2000 meter wiring loop. Each network extender allows expansion of the network by an additional 60 detectors and an additional 2000 meters of wiring (up to 250 nodes and 10,000 meters of wiring for the total loop).

When operating between +32°F and -40°F (0°C to -40°C) or between +158°F and +167°F (+70°C to +75°C), the number of additional nodes for each network extender is reduced from 60 to 40 nodes. An additional 2000 meters of wiring can still be accommodated. The maximum loop wiring distance (10,000 meters) as well as the maximum number of nodes allowed on the total communication loop (250) does not decrease, however, additional network extenders will be required.

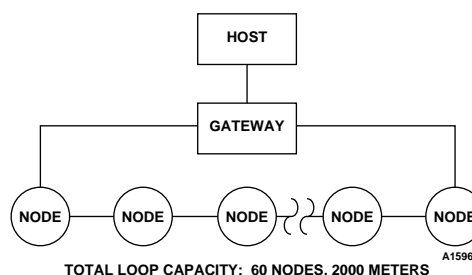

Figure 12—Basic Eagle System with One Gateway

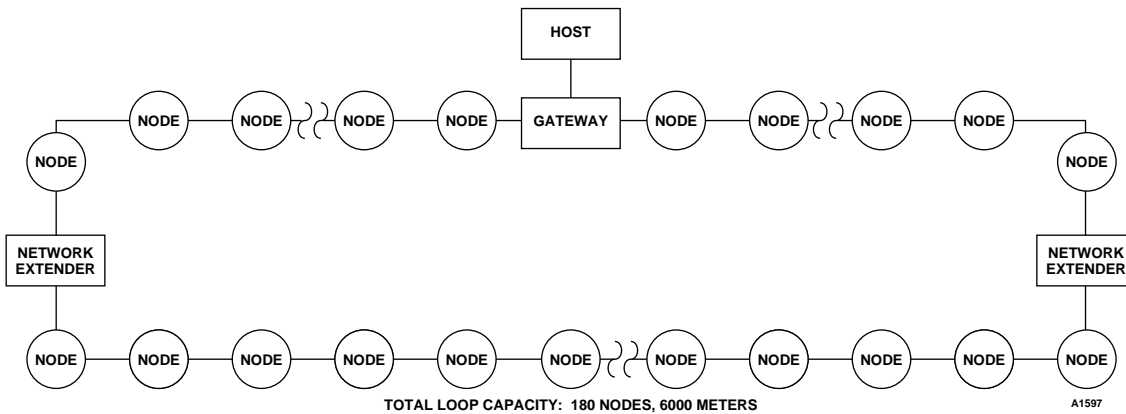

Figure 13—Expanded System with Two Network Extenders

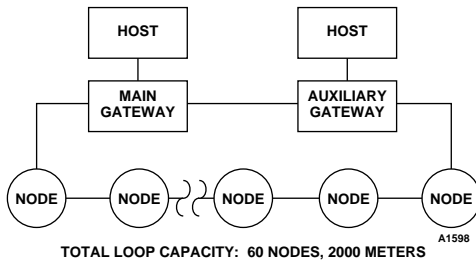

Figure 14—Eagle System with Two Gateways

## Section VI EA2500RM Relay Module

### APPLICATION

The Eagle Relay Module monitors a selected group of detection nodes on the digital communication loop. The relay module is furnished with a sealed SPDT relay and generates an output when the selected criteria for output actuation are met.

The specific status conditions to which the relay module will respond are selected at the time of configuration. These can include one or more of a variety of fault, alarm or calibration events.

### FEATURES

- Monitors from 1 to 248 nodes
- Configurable for common alarm or voting function
- Up to 105 relay modules on a communication loop
- Sealed 5 ampere SPDT relay
- Field addressable
- Fault isolation
- Pass through communication circuitry on power loss
- Non-volatile memory
- Accepts two digital contact inputs
- EMI hardened
- Screw terminal connectors.

### SPECIFICATIONS

**INPUT VOLTAGE—**  
18 to 32 vdc.

**INPUTS—**  
Two digital contact inputs, programmable for active low or high operation.

### RESPONSE TIME VERSUS SYSTEM SIZE

The Eagle 2000 is a highly versatile system that allows up to 250 detection points to operate on a single communication network.

When designing a system, it is important to realize that increasing the number of nodes on the communication loop results in a corresponding increase in the amount of time required for a status change message from a detection node to reach the host computer.

The communication system requires a finite length of time to process each bit of information that is transferred along the communication network. As the number of nodes increases, so does the amount of data that is being processed and the time required for processing the data. As a result, there is a corresponding increase in the total response time needed to receive the message from a node that is responding to a status change.

#### NOTE

*Increasing the number of detection nodes on the communication loop affects only the time needed for the status update message to reach the host computer. It does not adversely affect the time required for a detector to respond to an alarm condition and generate the appropriate output.*

If fast communication response time is an important criteria for a large system, it is recommended that the number of nodes on an individual loop be kept as small as practical. Consult the factory for specific information or for assistance in designing a system.

## OUTPUTS—

One SPDT sealed relay, rated 5 amperes resistive at 30 vdc, programmable for normally energized or normally de-energized operation.

## POWER CONSUMPTION—

60 ma nominal, 80 ma maximum at 24 vdc during normal operation with relay energized.

## TEMPERATURE RANGE—

Operating: -40°F to +167°F (-40°C to +75°C)  
Storage: -67°F to +170°F (-55°C to +77°C).

## DIMENSIONS—

See Figure 6.

## SHIPPING WEIGHT (Approximate)—

2.2 lbs. (1.0 kg).

## DESCRIPTION

The Eagle relay module consists of a terminal wiring board and an electronic module incorporating a state-of-the-art communication chip, mounted inside an explosion-proof aluminum enclosure.

## CONDITIONS FOR RELAY ACTUATION

The events or system status conditions to which the relay module can respond are defined in the lower eight bits of the communication module status word. See Table 4. When configuring the relay module, any or all of these conditions can be selected for relay actuation. Those conditions not selected will be ignored by the relay module. Since the relay module performs a logical “or” function on its associated communication modules, the occurrence of any of the selected conditions can generate an output.

## OPERATING MODES

The relay module must be configured to operate in either of two modes – the common alarm mode or the voting mode. These modes determine the conditions needed for the relay module to generate an output and also identify the group of detection nodes on the communication loop that will be monitored by the relay module.

### Common Alarm Mode

When operating in the common alarm mode, the relay module performs an “or” function, actuating its relay when any of the nodes within its group are in a status condition specified for relay actuation (Table 4). In the common alarm mode, the group of detection nodes monitored by the relay module consists of a block of sequential addresses that is defined by a starting and an ending address. These two addresses are programmed at the time of system configuration. The relay module responds

Table 4—Status Conditions Capable of Actuating Relay

| Communication Module Status Word Bit | Condition       |
|--------------------------------------|-----------------|
| 1                                    | Com 1 Fault     |
| 2                                    | Com 2 Fault     |
| 3                                    | Sensor Fault    |
| 4                                    | Calibration     |
| 5                                    | Alarm 1         |
| 6                                    | Alarm 2         |
| 7                                    | Digital Input 2 |
| 8                                    | Output Relay    |

to signals from only those communication modules with addresses that fall within the specified range.

## Voting Mode

As an alternative to the common alarm mode, the relay module can be configured to operate in the voting mode. In this operating mode, the relay module can monitor up to eight communication module addresses in its voting zone. These addresses are programmed individually and do not need to be sequential. Only signals from the specified addresses will be recognized. The relay is actuated when an event selected for output actuation occurs at the specified minimum number of individual nodes within the group (programmable from 1 to 8).

## INPUTS

The relay module has two digital contact inputs. These inputs can be programmed for active high or active low operation.

## OUTPUTS

The relay module is furnished with a sealed five ampere SPDT relay. The relay is programmable for either normally energized or normally de-energized operation.

The relay can be manually forced into the on or off state by the host device through the gateway.

When operating in the common alarm mode, the relay is latching and can be reset by the host device when events or system status conditions specified for relay actuation no longer exist. When operating in the voting mode, the relay module can be programmed for either latching or non-latching operation.

## STATUS UPDATE

The relay module sends a status message to the gateway at a field programmable rate between 1 and 10 seconds. The status message contains the present condition of the output and fault isolation relays, the two digital inputs, fault status, and the force relay on/off status.

## ADDRESSABILITY

Relay module identification is accomplished by setting rocker switches on an eight position DIP switch located on the electronic module. Valid addresses are from 5 to 110.

### NOTE

*Each relay module constitutes a node on the communication loop and counts as one of the 250 nodes maximum allowed on the total communication loop.*

## EVENT LOGGING

The relay module maintains a log of the eight most recent alarm events. Time and date are logged for each alarm. A maximum of eight events can be stored. If more than eight alarm events are logged, the oldest events will be lost.

## STATUS LEDs

Three LEDs are located at the center of the PC board on the electronic module. (The cover must be removed from the enclosure in order to view the LEDs.)

The green LED serves as a power-on indicator and is illuminated whenever power is applied. During normal operation, only the green LED is on.

The red LED indicates an alarm or fault condition. The flashing rate of the red LED indicates the following conditions:

|           |   |                  |
|-----------|---|------------------|
| On steady | = | Alarm condition  |
| Blinking  | = | Fault condition. |

An alarm condition has priority over a fault condition.

The amber LED is provided for factory diagnostic purposes and is not normally used in the field. A flashing amber LED indicates a problem with the communication chip.

## FAULT TOLERANT NETWORK

The relay module utilizes the same unique fault isolation technique for detecting a network wiring fault as the Eagle communication modules. The relay module contains both the software and hardware to isolate it in the event of a wiring fault. This allows communication to continue through the remainder of the network.

## WIRING

The serial communication loop is wired using level 4, 22 AWG shielded twisted pair wire. Wiring for power, inputs and outputs must be 18 AWG minimum.

All external wiring is connected to screw terminal connectors on the terminal wiring board that is factory mounted inside the enclosure. The electronic module is mounted inside the enclosure above the terminal wiring board and is connected to the terminal wiring board with a ribbon cable.

## ENCLOSURE

The watertight, explosion-proof aluminum enclosure is designed for use in Class I, Division 1, Groups B, C and D hazardous locations. It is designed to meet CENELEC requirements for EEx d IIC T5 hazardous locations, and is IP66 rated.

The enclosure is furnished with two 3/4 inch NPT conduit entries.

# Section VII System Installation

## GENERAL WIRING REQUIREMENTS

### NOTE

*The wiring procedures in this manual are intended to ensure proper functioning of the device under normal conditions. However, because of the many variations in wiring codes and regulations, total compliance to these ordinances cannot be guaranteed. Be certain that all wiring complies with applicable regulations that relate to the installation of electrical equipment in a hazardous area. If in doubt, consult a qualified official before wiring the system.*

All devices on the Eagle communication network are wired in a serial loop that starts and ends at the gateway. The use of 22 AWG level 4 shielded twisted pair cable is required for wiring the communication network. For other system wiring, 18 AWG minimum is recommended. All shields should be grounded at only one end to prevent ground currents.

### NOTE

*The recommended procedure for grounding the shields of the communication loop wiring requires the shields to be connected to each other inside the enclosure of each device on the loop, ensuring continuity of all shields on the loop. However, to prevent ground currents from flowing through the shield, the ends of the shield must be left disconnected at a single point on the loop (typically at a node midway around the loop). The shields must not be connected to earth ground at any of the device enclosures. The two shield ends are connected to earth ground at the gateway (Figure 15).*

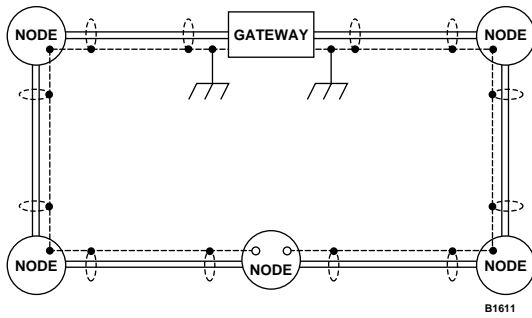

NOTE: SHIELDS GROUNDED AT GATEWAY ONLY.  
SHIELDS CONNECTED TO EACH OTHER (NOT TO GROUND)  
AT EACH NODE BUT OPEN AT ONE NODE NEAR MIDDLE OF LOOP.

Figure 15—Recommended Grounding for Cable Shields

Moisture can have a detrimental effect on the performance of electronic devices. Therefore, it is important to take proper precautions during installation to ensure that moisture will not come in contact with the electrical connections or components of the system.

In installations that do not use wiring conduit, the use of properly installed watertight glands is required to prevent the entry of moisture into the device enclosure.

In applications where the wiring cable is installed in conduit, the conduit must not be used for wiring to other electrical equipment. In addition, the use of conduit seals is required to prevent damage to electrical connections caused by condensation within the conduit.

Conduit seals must be watertight and explosion-proof and are to be installed even if they are not required by local wiring codes. A seal must be located as close to the enclosure as possible. In no case should this seal be located more than 18 inches (46 cm) from the device.

When pouring a seal, the use of a fiber dam is required to assure proper formation of the seal. Seals should never be poured in temperatures that are below freezing, since the water in the sealing compound will freeze and the compound will not dry properly. Contamination problems can result when temperatures rise above the freezing point and the compound thaws.

The shielding of the cable should be stripped back to permit the seal to form around the individual leads, rather than around the outside of the shield. This will prevent any siphoning action that can occur through the inside of the shield.

It is recommended that conduit breathers also be used. In some applications, alternate changes in temperature and barometric pressure can cause “breathing,” which allows the entry and circulation of moist air throughout the conduit. Joints in the conduit system and its components are seldom tight enough to prevent this

“breathing.” Moisture in the air can condense at the base of vertical conduit runs and equipment enclosures, and can build up over a period of time. This can be detrimental to electronic devices. To eliminate this condition, explosion-proof drains and breathers should be installed to automatically bleed off accumulated water.

Always observe the requirements of local codes.

**NOTE**

*Any deviation from the recommended wiring practices can compromise system operation. Consult the factory if different wiring types or methods are being considered.*

**NOTE**

*Many Eagle system electronic modules contain semiconductor devices that are susceptible to damage by electrostatic discharge. An electrostatic charge can build up on the skin and discharge when an object is touched. Therefore, use caution when handling, taking care not to touch the terminals or electronic components. For more information on proper handling, refer to Service Memo form 75-1005.*

**DETERMINING GAUGE OF POWER WIRING**

To ensure proper operation of the devices on the communication loop, it is important to consider the size of the power wiring. Since the resistance of the wiring will cause a drop in voltage across the wiring, the operating voltage at the input of the devices on the loop will be lower than the voltage at the output of the power supply. If the total resistance of the wiring is too great, the operating voltage will be too low for the device to operate properly. The following list of variables must be considered when selecting the power wiring:

**Wire size.** For any given length of wire, the total resistance is determined by the gauge of the wire. Table 5 shows the resistance of various wire gauges for each 1000 feet of copper wire.

**Wiring length.** The total resistance of a length of wire increases in direct proportion to the length of the wire.

Table 5—Typical Resistance for Stranded Copper Wire at 75°C

| Wire Size (AWG) | Ohms per 1,000 Feet at 75°C |
|-----------------|-----------------------------|
| 18              | 7.765                       |
| 16              | 4.884                       |
| 14              | 3.071                       |
| 12              | 1.931                       |
| 10              | 1.215                       |
| 8               | 0.764                       |

**Temperature.** Resistance increases as operating temperature rises. Calculate resistance at a worst case temperature of 75°C. See Table 5.

**Type of device.** Refer to the "Specifications" section for current ratings. Always consider the maximum (not nominal) current draw of each device. This typically occurs at startup and/or when relays are energized. Note that combustible gas DCUs draw considerably more current than other DCU models.

**Number of units per wiring run.** Add the totals of all units on the wiring run.

**Allowable voltage drop.** The DCU needs a minimum of 18 vdc (measured at the DCU) to ensure proper operation. Subtract 18 vdc from the power supply output voltage to determine the maximum allowable voltage drop.

The maximum wiring limits can be calculated using Ohm's law and the information in Table 5.

**Example A:**

What is the longest wiring distance for one combustible gas DCU using 18 AWG wire?

**NOTE**

*For the following examples, assume that a 24 vdc nominal power supply is being used. A combustible gas DCU draws approximately 500 ma at startup.*

24 vdc (power supply output) minus 18 vdc (minimum voltage required) = 6 vdc (maximum allowable voltage drop).

Voltage ÷ Current = Resistance (Ohm's law)

Maximum allowable voltage drop ÷ maximum current draw = maximum allowable resistance

6 vdc ÷ 500 ma = 12 ohms

12 ohms ÷ 7.765 (resistance for 1000 ft. 18 AWG wire) = 1.55

1.55 x 1000 = 1550 feet

**Example B:**

How many combustible gas DCUs can operate at the end of a 1000 foot length of 14 AWG wire?

Voltage ÷ Resistance = Current (Ohm's law)

Maximum allowable voltage drop ÷ resistance for 1000 ft. of 14 AWG wire = maximum current draw

6 vdc ÷ 3.071 ohms = 1.95 amps

1.95 amps ÷ 500 ma (current draw per unit) = 4 units

**Example C:**

What wire size is needed to power 10 combustible gas DCUs at a distance of 500 feet from the power supply?

10 units x 500 ma (maximum current draw per unit) = 5 amps (total current draw at startup)

Voltage ÷ Current = Resistance (Ohm's law)

Maximum allowable voltage drop ÷ Total current draw = maximum allowable resistance for 500 feet of wire

6 vdc ÷ 5 amps = 1.2 ohms

500 feet of 12 AWG wire is 0.9665 ohms

**NOTE**

*The following section provides a general description of the basic procedure for installing the Eagle system. Before wiring any Eagle device, refer to the instruction manual that was provided with the device for complete installation and wiring instructions:*

|                             |                |
|-----------------------------|----------------|
| <i>Communication Module</i> | <i>95-8425</i> |
| <i>DCU</i>                  | <i>95-8426</i> |
| <i>Network Extender</i>     | <i>95-8430</i> |
| <i>Relay Module</i>         | <i>95-8423</i> |
| <i>Gateway</i>              | <i>95-8424</i> |

## COMMUNICATION MODULE AND DCU WIRING

1. Determine the best mounting locations for the detectors. Whenever practical, detectors should be placed where they are easily accessible for calibration. Gas sensors should be pointing down to minimize the accumulation of contaminants on the filter and to ensure proper operation. Junction boxes should be electrically connected to earth ground.
2. Install the detectors as directed in the detector instruction manual.
3. Remove the cover from the junction box.

### NOTE

*Do not apply power to the system with the junction box cover removed unless the area has been de-classified.*

4. Connect external system wiring to the appropriate terminals on the terminal block inside the junction box. See Figure 16.

### CAUTION

*The gateway and communication modules will be damaged if power is inadvertently applied to the communication lines. The communication module is protected against damage caused by switching polarity of the power lines.*

5. Check the wiring to ensure proper connections, then pour the conduit seals and allow them to dry (if conduit is being used).
6. Set the node address for the communication module. Valid addresses are from 1 to 250. If the address is set to zero or an address above 250, the communication module will ignore the switch setting. Duplicated addresses are not automatically detected. All modules with the same address will report on that address. The status word will show the latest update, which could be from any of the reporting modules at that address.

Address selection is accomplished by setting rocker switches on the DIP switch assembly on the communication module circuit board. Each rocker switch has a specific binary value (Figure 17). The node address is equal to the added value of all closed rocker switches. All open switches are ignored. For example: for node No. 5, close rocker switches 1 and 3 (binary values 1 + 4); for node 25, close rocker switches 1, 4 and 5 (binary values 1 + 8 + 16).

7. Install the electronic module inside the junction box. Refer to Figure 7. Be sure that the ribbon cable is properly connected.

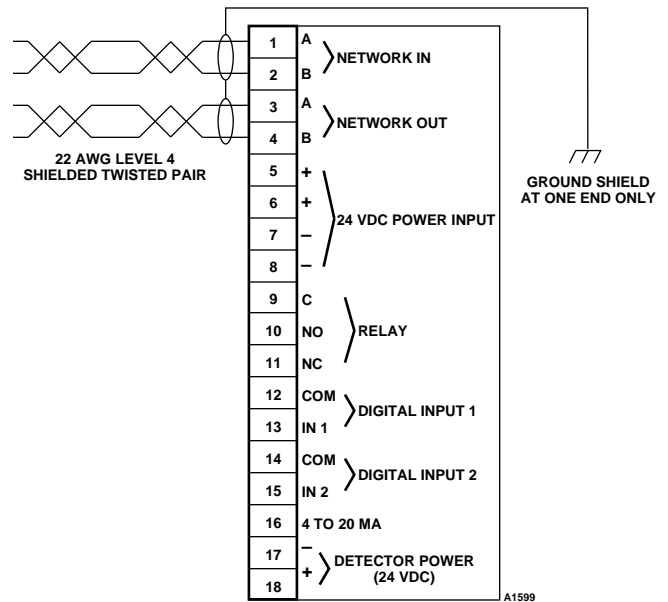

Figure 16—Wiring Configuration for Communication Module and DCU

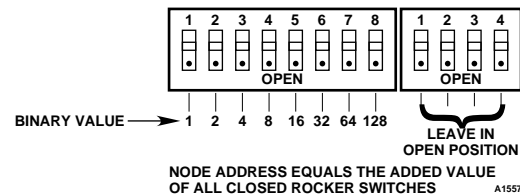

Figure 17—Communication Module Address Switches

8. Inspect the junction box O-ring to be sure that it is in good condition and properly installed. Lubricate the O-ring and the threads of the junction box cover with a thin coat of an appropriate grease to ease installation and ensure a water-tight enclosure. The recommended lubricant is a silicone free polyalphaolefin grease, available from Det-Tronics. If the installation uses catalytic type combustible gas sensors, it is imperative that lubricants containing silicone not be used, since they will cause irreversible damage to the sensor. Place the cover on the junction box. Tighten only until snug. Do not over tighten.

## TYPICAL APPLICATIONS

Figure 18 illustrates a typical system consisting of communication modules used with a U8700 or U8800 Transmitter.

Figure 19 illustrates communication modules or DCUs with toxic gas sensors.

Figure 20 shows communication modules or DCUs with combustible gas sensors and transmitters. (A DCU has the combustible gas transmitter mounted inside the DCU enclosure.)

Figure 21 illustrates a typical system consisting of communication modules with various flame detection devices.

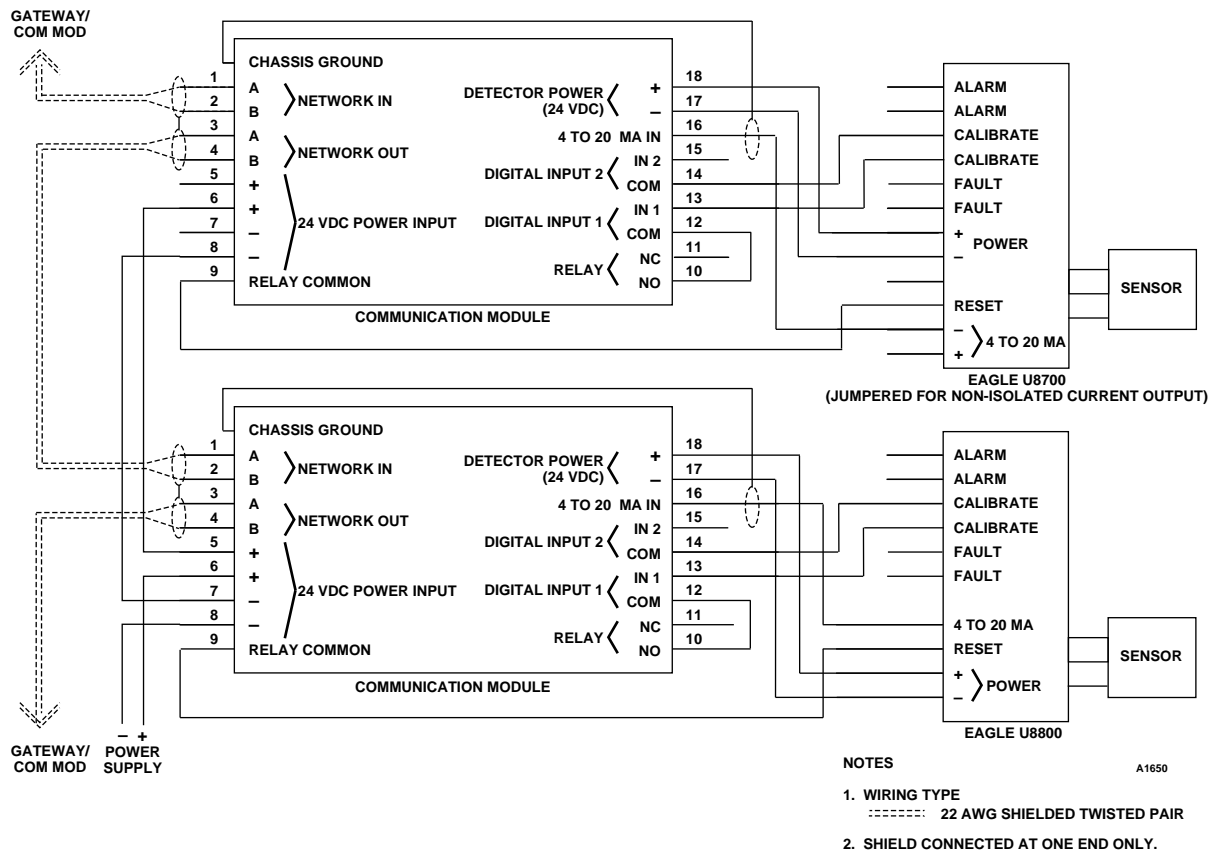

Figure 18—A Typical Application – Communication Module with an Eagle U8700 or U8800 Detector

## GATEWAY WIRING

### Field Wiring Connector

The gateway is furnished with a field wiring connector backplate that incorporates pressure type screw terminals for connecting the external wiring and a circuit board edge connector for attaching to the gateway.

The use of a mounting rack is required for mounting the gateway. The backplate is attached to the back of the rack to allow easy removal of the gateway without disturbing the wiring. See Figures 22 and 23.

The gateway is designed for installation in a non-hazardous area.

Figure 24 shows the terminal configuration.

### Typical Application

Figure 25 illustrates a typical system consisting of a gateway, communication modules and an OIS. One communication module is shown with a U8700/U8800 Transmitter.

Figure 26 shows the communication loop and power wiring for a typical system consisting of a gateway, communication module, network extender and relay module.

### CAUTION

*The gateway will be damaged if power is inadvertently applied to the communication lines. The gateway is protected against damage caused by switching polarity of the power lines.*

### GATEWAY SWITCH SETTINGS

The gateway contains four 8-position DIP switch assemblies that are used for:

- Selecting the serial port hardware and software parameters
- Setting the gateway Modbus address
- Selecting the main gateway
- Setting the gateway address.

Refer to Figure 27 to identify the function of the DIP switches. Refer to Figure 28 to locate the DIP switch assemblies on the side of the gateway.

### NOTE

*Close switch to enable function.*



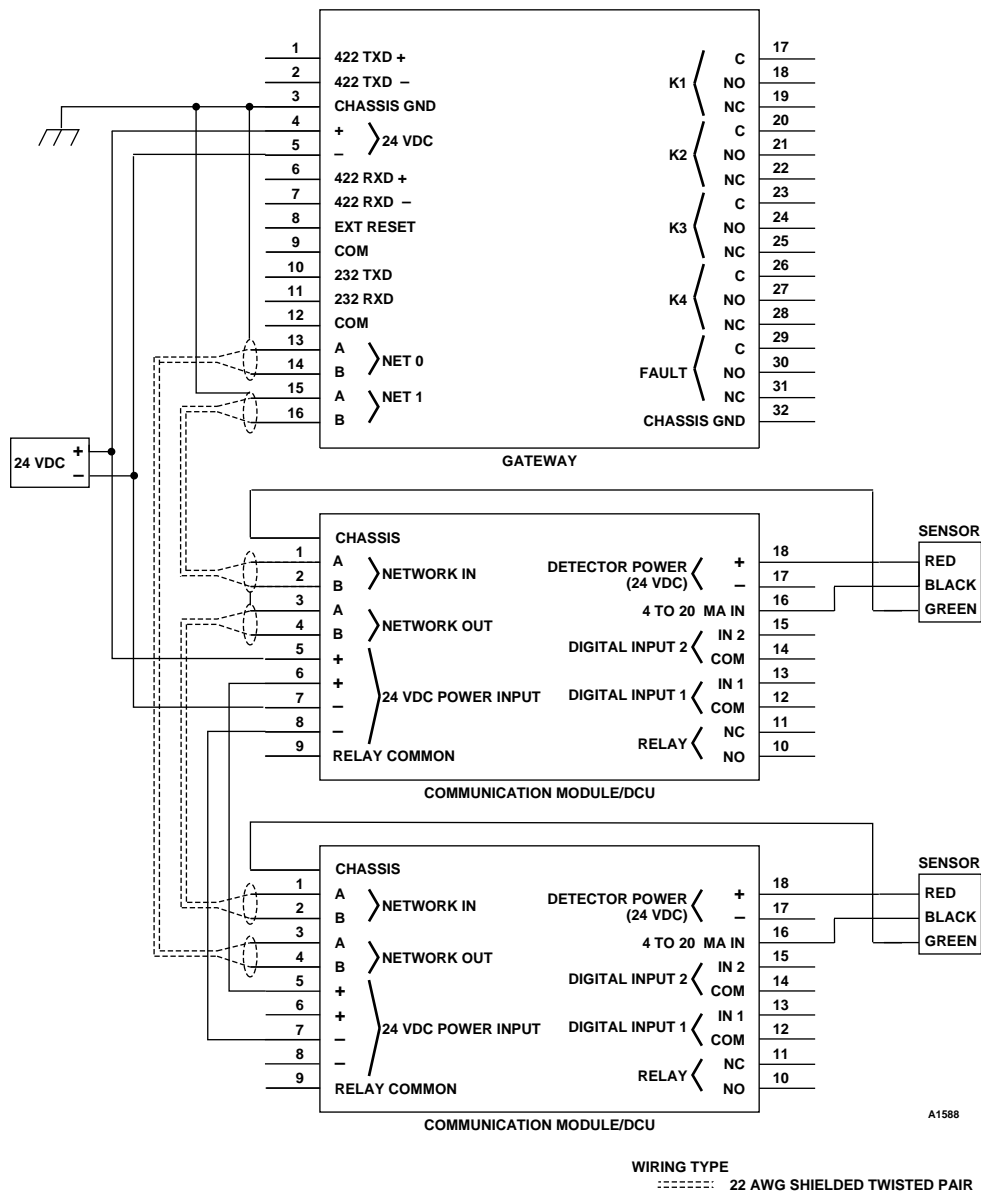

Figure 19—A Typical Application – Communication Modules or DCUs with Toxic Gas Sensors

### S5 – Hardware Serial Port Configuration

- 1 and 2 Channel 0 not used. Leave switches open.
- 3 Close if RS-232 is used.
- 4 Close if RS-422 is used. (Macintosh uses RS-422.)
- 5 and 6 Channel 0 not used. Leave switches open.
- 7 and 8 Close switches.

### S6 – Software Serial Port Configuration

- 1, 2, and 3 Determine the desired baud rate, then refer to Table 6 for the proper switch settings. (19,200 is recommended.)
- 4 Leave switch open (no parity).
- 5 Leave switch open (odd parity).
- 6 Leave switch open (1 stop bit).
- 7 Close switch (8 data bits).
- 8 Leave switch open.

### S7 – Modbus Address

Set switches to match Modbus slave address. Setting must be different for each gateway, unless redundant gateways are used. (Backup gateway must have same address as main gateway.) "0" is not a valid address.

### S8 – Network Configuration

- 1 and 2 Set gateway address switches according to Table 7.
- 3 to 5 Not used. Leave open.
- 6 Close for non-latching gateway relays.
- 7 Close switch if gateway is to function as a backup gateway. Switch must be open for main or auxiliary gateway.
- 8 Close for main gateway, open for all other gateways.

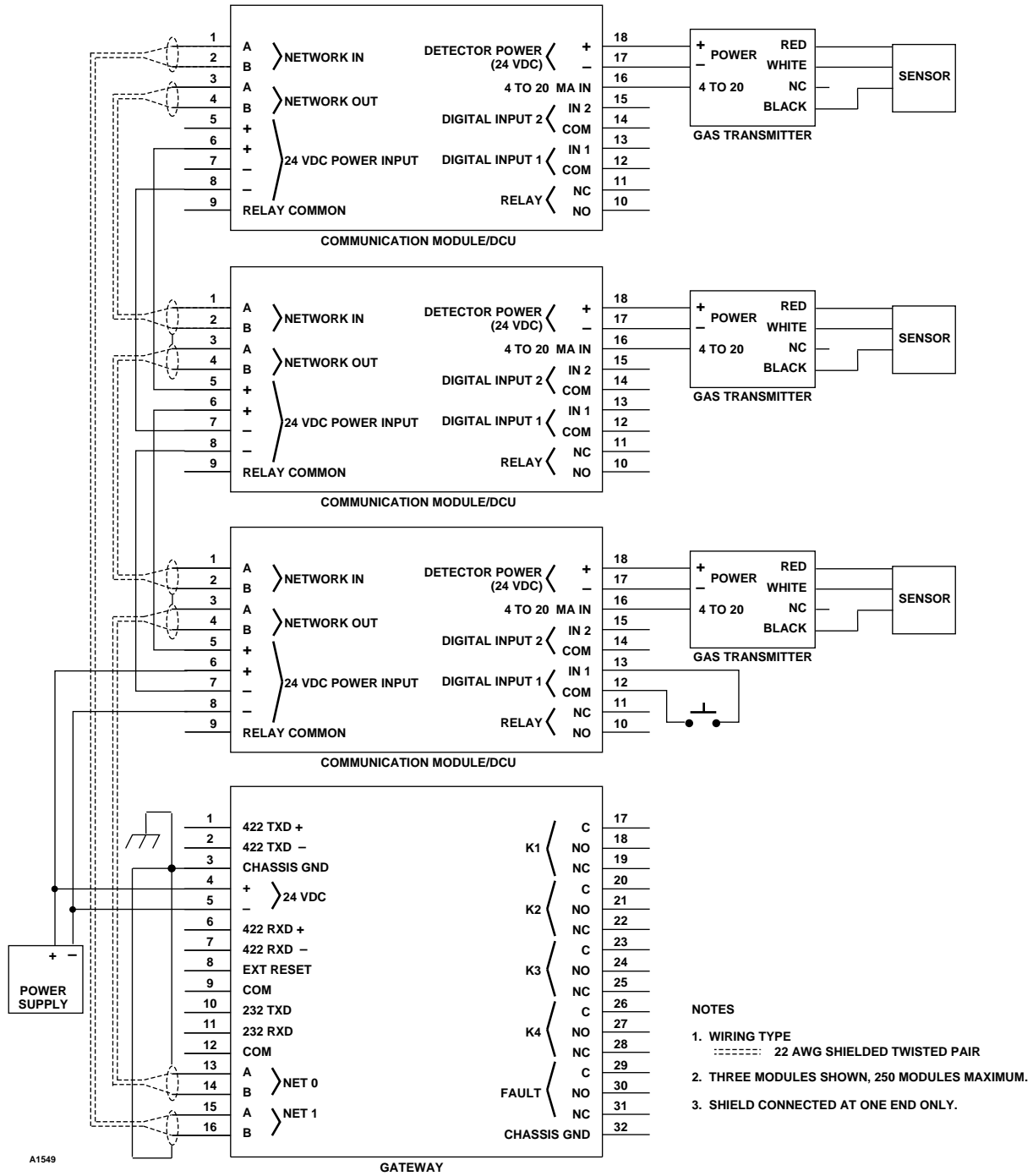
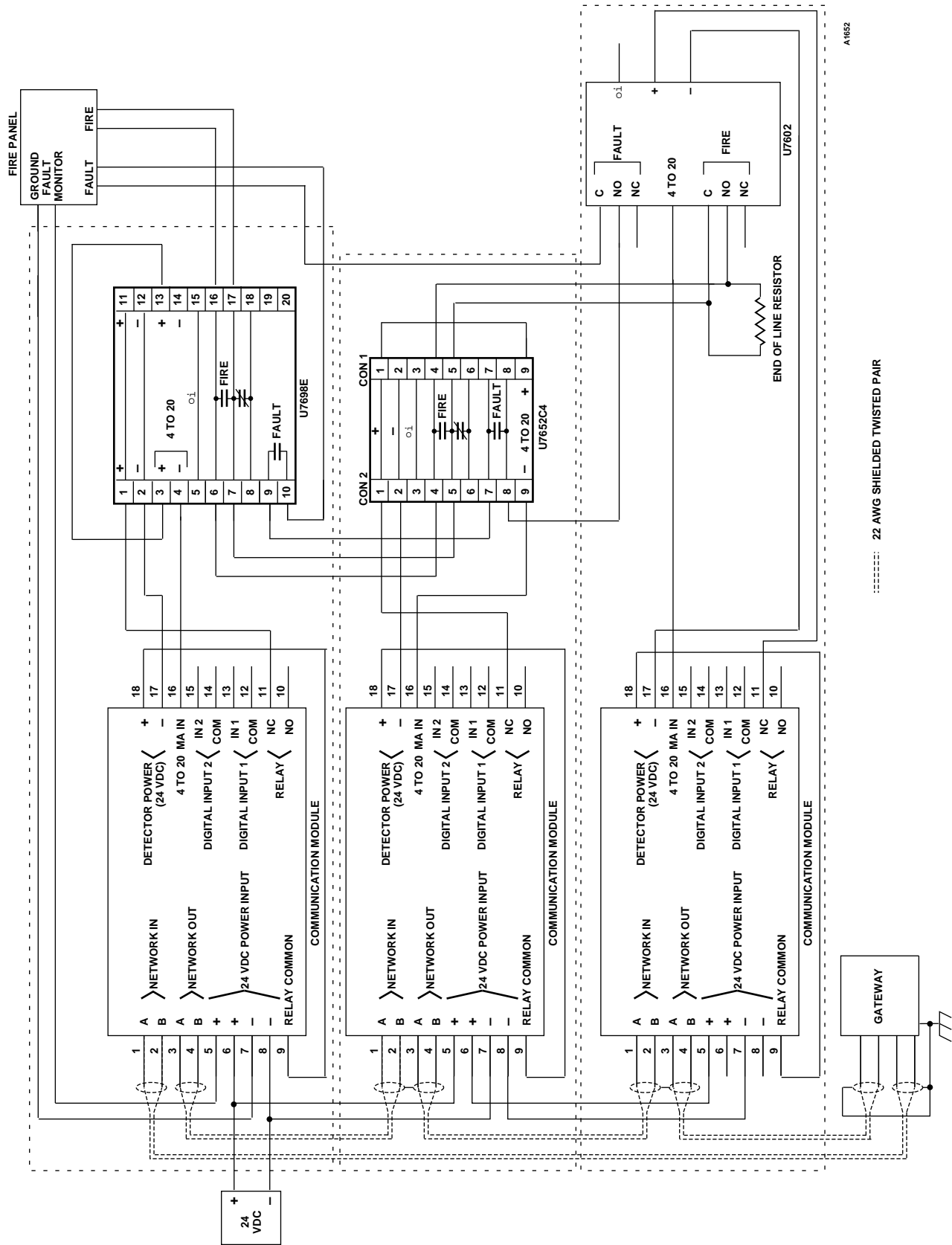

Figure 20—A Typical Application – Communication Modules or DCUs with Combustible Gas Sensors and Transmitters



..... 22 AWG SHIELDED TWISTED PAIR

A1652

Figure 21—A Typical Application – Communication Modules with Flame Detection Devices

| RACK TYPE | PART NUMBER<br>005269-XXX | CONTROLLER POSITIONS FOR: |     | HT: | DIM. (A) |       | DIM. (B) |       | DIM. (C) |       | DIM. (D) |       | DIM. (E) |       |
|-----------|---------------------------|---------------------------|-----|-----|----------|-------|----------|-------|----------|-------|----------|-------|----------|-------|
|           |                           | FIRE                      | GAS |     | INCH     | MM    | INCH     | MM    | INCH     | MM    | INCH     | MM    | INCH     | MM    |
| 4U        | -001                      | 8                         | 16  | 4U  | 19.00    | 482.6 | 18.30    | 464.8 | 17.36    | 440.9 | 4.00     | 101.6 | 6.97     | 177.1 |
| 4U        | -002                      | 6                         | 12  | 4U  | 15.06    | 382.6 | 14.36    | 364.7 | 13.42    | 340.9 | ↓        | ↓     | ↓        | ↓     |
| 4U        | -003                      | 4                         | 8   | 4U  | 11.13    | 282.6 | 10.43    | 264.9 | 9.49     | 241.1 |          |       |          |       |
| 4U        | -004                      | 3                         | 6   | 4U  | 9.16     | 232.7 | 8.46     | 214.9 | 7.52     | 191.0 |          |       |          |       |
| 4U        | -005                      | 2                         | 4   | 4U  | 7.19     | 182.7 | 6.49     | 164.9 | 5.55     | 141.0 |          |       |          |       |
| 4U        | -006                      | 1                         | 2   | 4U  | 5.22     | 132.6 | 4.52     | 114.8 | 3.58     | 90.9  |          |       |          |       |
| 3U        | -007                      |                           | 16  | 3U  | 19.00    | 482.6 | 18.30    | 464.8 | 17.36    | 440.9 |          |       |          |       |
| 3U        | -008                      |                           | 12  | 3U  | 15.06    | 382.6 | 14.36    | 364.7 | 13.42    | 340.9 | ↓        | ↓     | ↓        | ↓     |
| 3U        | -008                      |                           | 8   | 3U  | 11.13    | 282.6 | 10.43    | 264.9 | 9.49     | 241.1 |          |       |          |       |
| 3U        | -010                      |                           | 6   | 3U  | 9.16     | 232.7 | 8.46     | 214.9 | 7.52     | 191.0 |          |       |          |       |
| 3U        | -011                      |                           | 4   | 3U  | 7.19     | 182.7 | 6.49     | 164.9 | 5.55     | 141.0 |          |       |          |       |
| 3U        | -012                      |                           | 2   | 3U  | 5.22     | 132.6 | 4.52     | 114.8 | 3.58     | 90.9  |          |       |          |       |

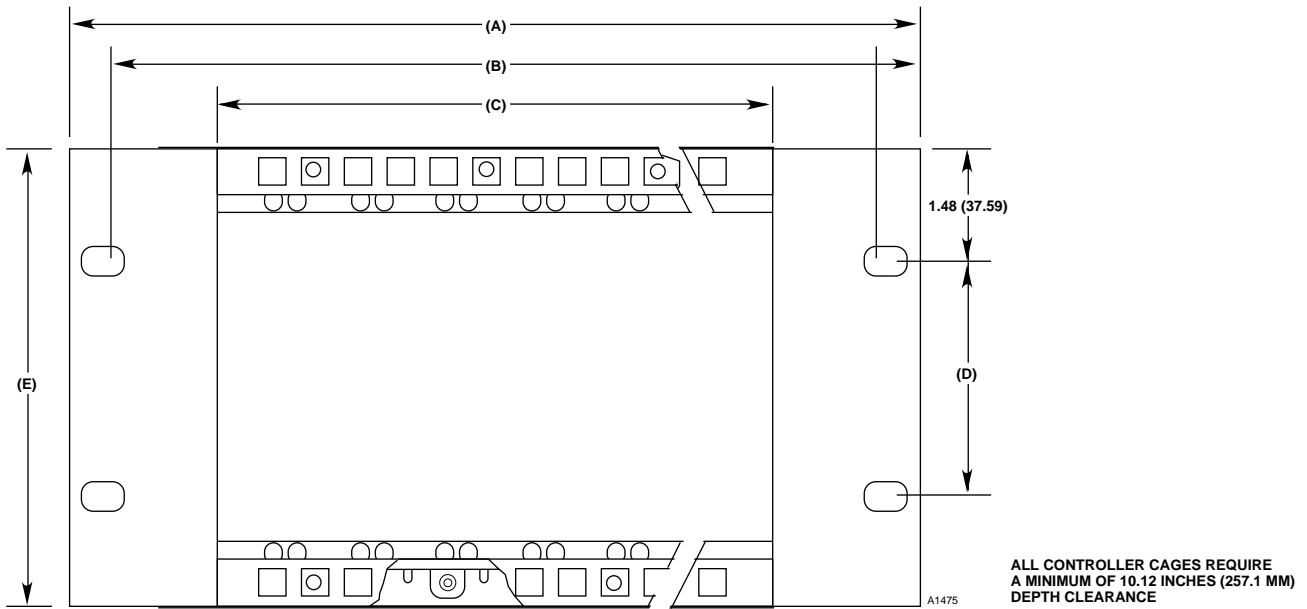

Figure 22—Dimensions of Q4004 Mounting Rack

THE Q4004 CONTROLLER CAGE HAS BEEN MODIFIED TO ACCOMMODATE EITHER FIRE OR GAS CONTROLLERS OR ANY COMBINATION OF THE TWO. BY FOLLOWING THE INSTRUCTIONS BELOW, THE CAGE CAN BE SET UP TO ANY CONFIGURATION.

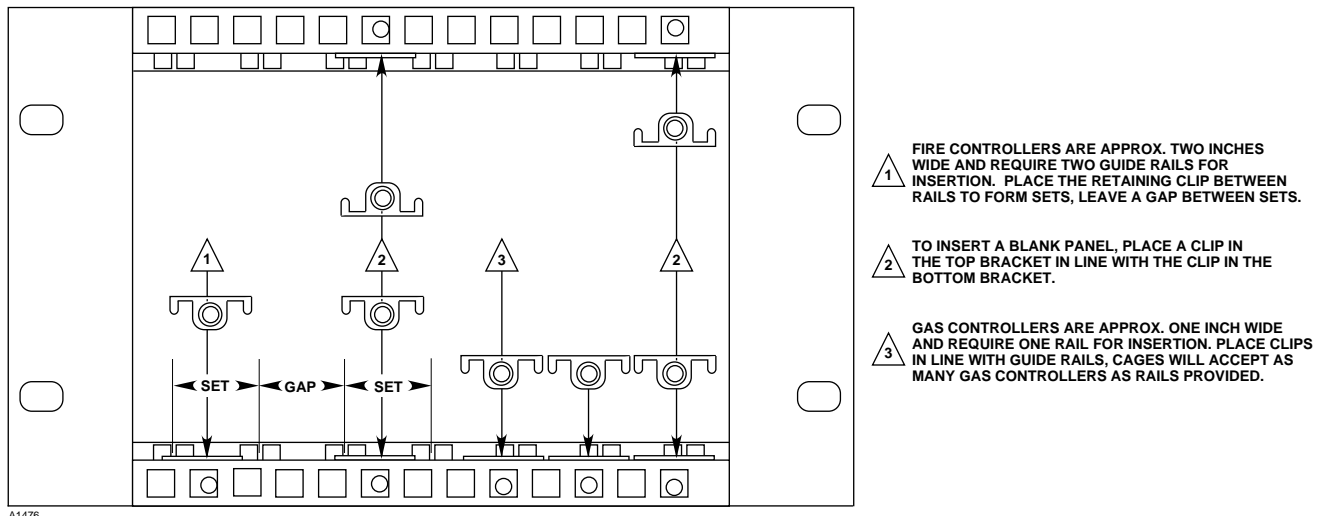

Figure 23—Clip Positioning for Q4004 Mounting Racks

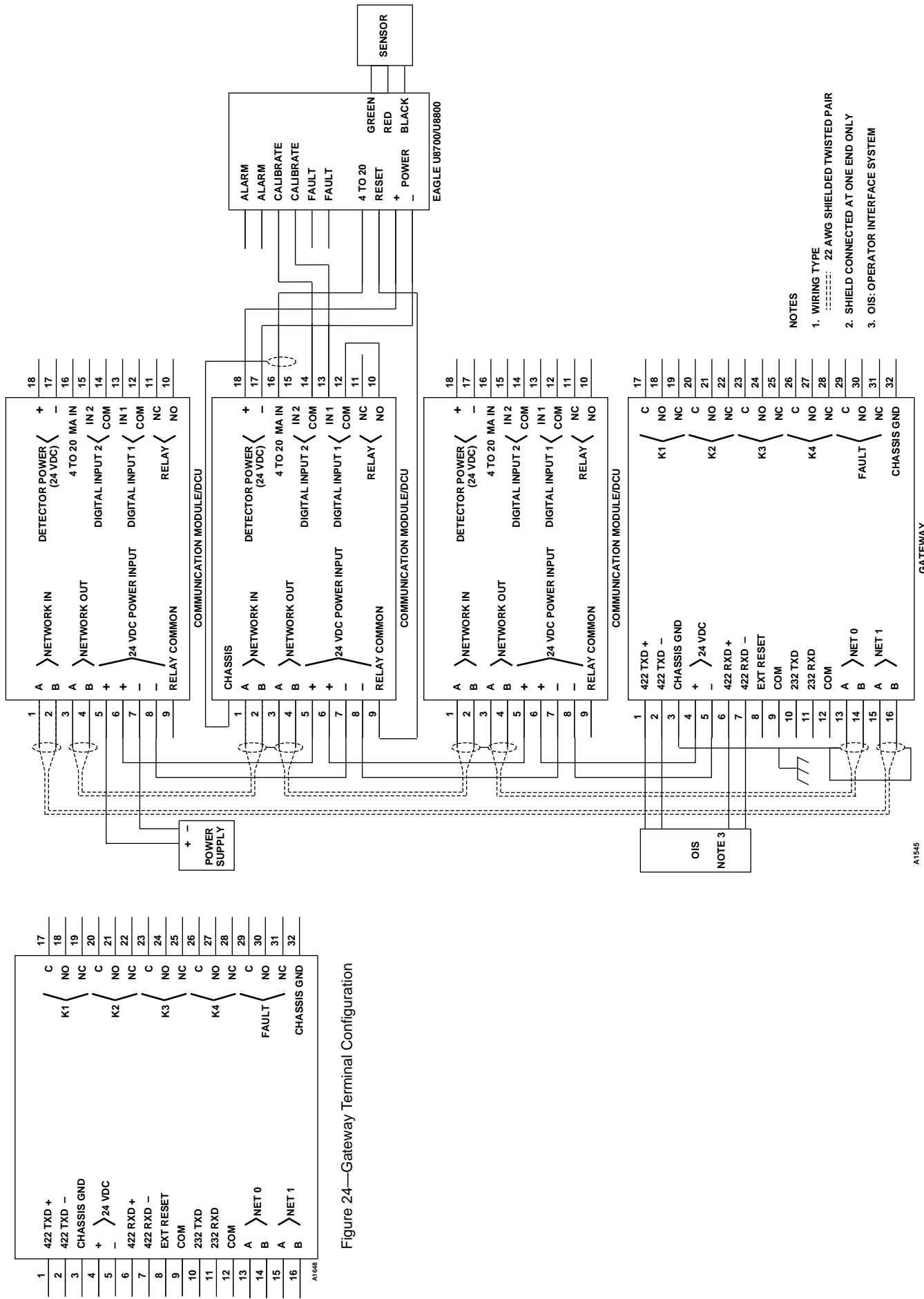

Figure 24—Gateway Terminal Configuration

- NOTES
1. WIRING TYPE  
-----: 22 AWG SHIELDED TWISTED PAIR
  2. SHIELD CONNECTED AT ONE END ONLY
  3. OIS: OPERATOR INTERFACE SYSTEM

Figure 25—A Typical Eagle System with Gateway, Communication Modules and OIS



**S8 LON CONFIGURATION**

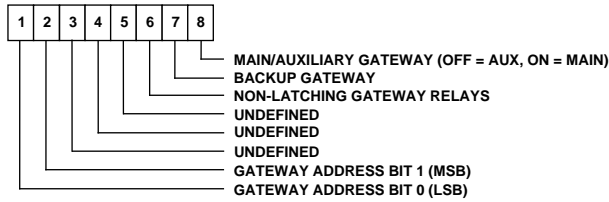

**S7 MODBUS ADDRESS**

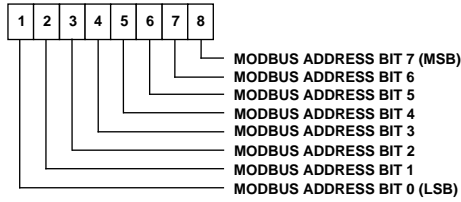

**S6 SOFTWARE SERIAL PORT CONFIGURATIONS (CHANNEL 1 ONLY)**

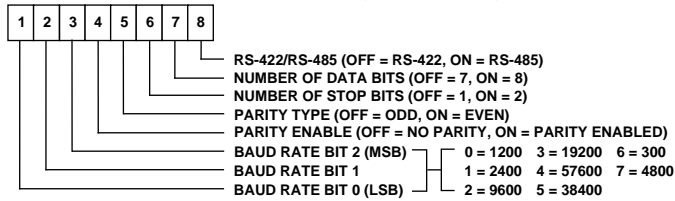

**S5 HARDWARE SERIAL PORT CONFIGURATIONS**

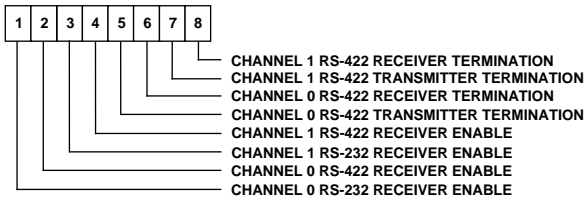

Figure 27—Gateway DIP Switch Assignments

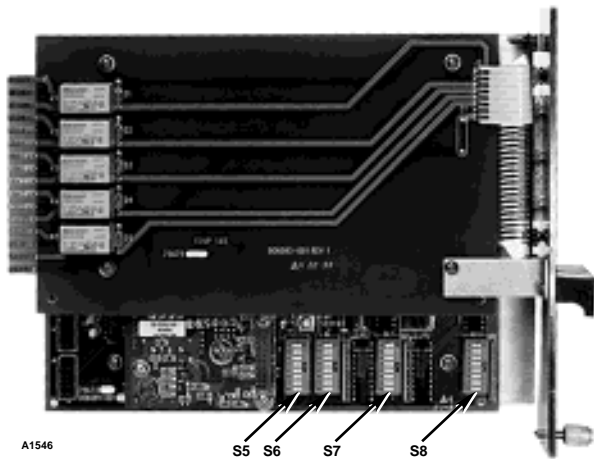

Figure 28—Gateway DIP Switch Location

Table 6—Baud Rate Selection – Switches S6-1, S6-2, S6-3

| BAUD RATE | SWITCH POSITIONS |    |    |
|-----------|------------------|----|----|
|           | 1                | 2  | 3  |
| 1200      | Op               | Op | Op |
| 2400      | Cl               | Op | Op |
| 9600      | Op               | Cl | Op |
| 19,200    | Cl               | Cl | Op |
| 57,600    | Op               | Op | Cl |
| 38,400    | Cl               | Op | Cl |
| 300       | Op               | Cl | Cl |
| 4800      | Cl               | Cl | Cl |

Op = Open  
Cl = Closed

Table 7—Gateway Address – Switches S8-1, S8-2

| GATEWAY FUNCTION | SWITCH POSITIONS |    |
|------------------|------------------|----|
|                  | 1                | 2  |
| Main Gateway     | Op               | Op |
| 1st Aux. Gateway | Cl               | Op |
| 2nd Aux. Gateway | Op               | Cl |
| 3rd Aux. Gateway | Cl               | Cl |

Op = Open  
Cl = Closed

## INSTALLATION CHECKLIST

The following checklist is provided as a means of double checking the system to be sure that all phases of system installation are complete and have been performed correctly.

1. Junction boxes are mounted securely and detectors are pointing in the proper direction.
2. All cable shields are properly grounded.
3. All junction box covers are tightly installed.
4. Explosion-proof conduit seals or watertight glands have been installed at all junction box entries.
5. Sensor and communication network wiring is correct.
6. Power wiring is installed and power source is operational.
7. External loads are properly connected.
8. DIP switches on the communication modules are set correctly. Record this information for future reference.
9. Gateway switches are set as desired. Record this information for future reference.
10. Gateway is properly installed in the mounting rack.
11. Proper ventilation is provided (if needed) to prevent equipment over-heating.

Proceed to System Startup.

## Section VIII System Startup

### STARTUP PROCEDURE

1. Output loads that are controlled by the system should be secured (remove power from all output devices) to prevent actuation.
2. Check all system wiring for proper connection.
3. Before installing the gateway in the mounting rack, inspect it to verify that it has not been physically damaged in shipment. Check the rocker switches for proper programming, then slide the gateway fully into the mounting rack.
4. Apply power to the system.

#### NOTE

*To prevent the communication modules from going into a fault isolation condition, it is recommended that power be applied to the gateway prior to applying power to the communication modules.*

5. Program the system for the desired operation. Download configuration data to all devices.

#### NOTE

*After system configuration has been completed, the entire system should be tested for proper operation to ensure that configuration was performed properly.*

6. Calibrate the sensors.
7. Remove mechanical blocking devices (if used) and restore power to the output loads.

### SYSTEM CONFIGURATION

The host device connected to the Modbus port of the gateway configures the communication modules by setting two words of configuration data in predefined registers in the gateway. The gateway uses these two words of data to determine configuration information that will be transferred to the appropriate communication module.

Other operating parameters such as alarm setpoints and calibration gas concentration can be changed using the gateway transfer buffer in conjunction with the control word for the communication module.

For complete information regarding system configuration, refer to the Det-Tronics EagleVision Software manual for systems equipped with the Det-Tronics Operator Interface System. For other systems, refer to form 95-8433 for configuration information.

### CALIBRATION

To ensure optimum protection, calibration must be performed on a regularly scheduled basis. Since each application is different, the length of time between regularly scheduled recalibrations can vary from one installation to the next. In general, the more frequently a system is checked, the greater the reliability.

#### IMPORTANT

*To ensure adequate protection, calibration must be performed on a regularly scheduled basis.*

Refer to the sensor manual for additional information regarding calibration.

#### NOTE

*The calibration will be aborted and the detector will revert back to the previous calibration values if the calibration is not completed within 12 minutes. The red LED will turn off, the calibrate bit will be reset, and the calibration fault bit will be set in the communication module status word. The calibration will be logged as aborted.*

### CALIBRATION ALGORITHMS

The following section describes the calibration sequences that are used for calibrating various detection devices. Refer to the System Configuration Matrix, form number 95-8453, to determine the calibration algorithm that is used for the type of detector being calibrated. Refer to Figures 29 to 33 for calibration algorithms.

#### NOTE

*Some calibration procedures require the operator to activate the reed switch in the communication module. To activate the reed switch, place the magnetic calibration tool on the side of the enclosure midway between the two mounting holes, approximately one inch above the mounting surface (approximately 3 1/2 inches above the mounting surface for intrinsically safe DCUs). Hold the magnetic calibration tool in place for 4 seconds to initiate steps of the calibration procedure.*



## CALIBRATION ALGORITHM A (Type Codes 1, 2, 3, 4) for Gas Detectors

### Normal Calibration

1. Activate the reed switch or input 1 on the communication module (See Figure 29). The red LED blinks at a 2 Hz rate while the reed switch or input 1 is closed.
2. After the reed switch has been closed for 3 seconds, the calibrate LED on the communication module flashes at a 1 Hz rate, indicating that it is ready for the zero input. The calibrate bit in the communication module status word is set.
3. Apply the zero input (4 ma).
4. Activate the reed switch or input 1 on the communication module. The red LED will blink at a 2 Hz rate for 3 seconds while the reed switch or input 1 is closed.
5. After the reed switch or input 1 has been closed for 3 seconds, the communication module records the uncalibrated value in the calibration log and calibrates the zero value. The calibrate LED goes on steady.
6. Apply the calibration gas.
7. The calibrate LED blinks at a 1 Hz rate when the input increases.
8. Activate the reed switch or input 1 on the communication module. The red LED blinks at a 2 Hz rate while the reed switch or input 1 is closed.
9. The communication module records the uncalibrated value in the calibration log and calibrates the span value after the reed switch or input 1 is on for 3 seconds.
10. The calibrate LED goes on steady.
11. Remove the span gas and return the analog input to normal.
12. Activate the reed switch or input 1 on the communication module. The red LED blinks at a 2 Hz rate for 3 seconds while the reed switch or input 1 is closed.
13. The calibration is complete. The calibrate LED turns off and the calibrate bit in the status word is reset.

If the calibration is not completed within 12 minutes, the previous calibration values are restored and the calibration is logged as aborted. The calibrate LED flashes at a 4 Hz rate, the calibrate bit in the status word is reset and the calibration fault bit is set.

### Calibration After Sensor Replacement

1. Open the junction box cover and press the sensor replacement switch.
2. The calibrate LED on the communication module flashes at a 1 Hz rate, indicating it is ready for the zero input. The calibrate bit in the status word is set.
3. Replace the sensor and apply the zero input (4 ma).
4. Activate the reed switch or input 1 on the communication module. The red LED blinks at a 2 Hz rate for 3 seconds while the reed switch or input 1 is closed.
5. The communication module records the uncalibrated value in position one of the calibration log and calibrates the zero value. The calibrate LED goes on steady.
6. Apply the calibration gas.
7. The calibrate LED blinks at a 1 Hz rate when the input increases.
8. Activate the reed switch or input 1 on the communication module. The red LED blinks at a 2 Hz rate for 3 seconds while the reed switch or input 1 is closed.
9. The communication module records the uncalibrated value in the first register of the calibration log and calibrates the span value.
10. The calibrate LED goes on steady.
11. Remove the span gas and return the analog input to normal.
12. Activate the reed switch or input 1 on the communication module. The red LED blinks at a 2 Hz rate for 3 seconds while the reed switch or input 1 is closed.
13. The calibration is complete. The calibrate LED turns off and the calibrate bit in the status word is reset.

Pressing the sensor replacement switch aborts the calibration and starts over. Resetting the communication module will abort sensor replacement.

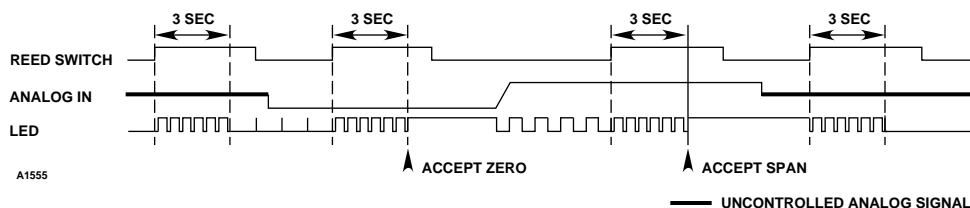

Figure 29—Calibration Algorithms "A" and "F"

## **CALIBRATION ALGORITHM A (Type Codes 1, 2, 3, 4) for Environmental Monitors**

### **Normal Calibration**

1. Activate the reed switch or input 1 on the communication module. The red LED blinks at a 2 Hz rate for 3 seconds while the reed switch or input 1 is closed.
2. The calibrate LED on the communication module flashes at a 1 Hz rate, indicating that it is ready for the zero input. The calibrate bit in the communication module status word is set.
3. Perform the PathWatch zero calibration.
4. Activate the reed switch or input 1 on the communication module. The red LED will blink at a 2 Hz rate for 3 seconds while the reed switch or input 1 is closed.
5. The communication module records the uncalibrated value in the calibration log and calibrates the zero value. The calibrate LED goes on steady.
6. Perform the PathWatch span calibration.
7. The calibrate LED blinks at a 1 Hz rate when the input increases.
8. Activate the reed switch or input 1 on the communication module. The red LED blinks at a 2 Hz rate for 3 seconds while the reed switch or input 1 is closed.
9. The communication module records the uncalibrated value in the calibration log and calibrates the span value.
10. The calibrate LED goes on steady.
11. Remove the span gas and re-adjust the zero potentiometer if necessary.
12. Activate the reed switch or input 1 on the communication module. The red LED blinks at a 2 Hz rate for 3 seconds while the reed switch or input 1 is closed.
13. The calibration is complete. The calibrate LED turns off and the calibrate bit in the status word is reset.

If the calibration is not completed within 12 minutes, the previous calibration values are restored and the calibration is logged as aborted. The calibrate LED blinks at a 4 Hz rate, the calibration fault bit in the status word is set, and the calibrate bit is reset.

### **Calibration After Sensor Replacement**

1. Open the communication module junction box cover and press the sensor replacement switch.
2. The calibrate LED on the communication module flashes at a 1 Hz rate, indicating it is ready for the zero input. The calibrate bit in the status word is set.
3. Perform the PathWatch zero calibration.
4. Activate the reed switch or input 1 on the communication module. The red LED blinks at a 2 Hz rate for 3 seconds while the reed switch or input 1 is closed.
5. The communication module records the uncalibrated value in position one of the calibration log and calibrates the zero value. The calibrate LED goes on steady.
6. Perform the PathWatch span calibration.
7. The calibrate LED blinks at a 1 Hz rate when the input increases.
8. Activate the reed switch or input 1 on the communication module. The red LED blinks at a 2 Hz rate for 3 seconds while the reed switch or input 1 is closed.
9. The communication module records the uncalibrated value in the first register of the calibration log and calibrates the span value.
10. The calibrate LED goes on steady.
11. Remove the span gas. Re-adjust the zero potentiometer if necessary.
12. Activate the reed switch or input 1 on the communication module. The red LED blinks at a 2 Hz rate for 3 seconds while the reed switch or input 1 is closed.
13. The calibration is complete. The calibrate LED turns off and the calibrate bit in the status word is reset.

Pressing the sensor replacement switch aborts the calibration and starts over. Resetting the communication module will abort sensor replacement.

## CALIBRATION ALGORITHM B (Type Codes 5, 6)

### Normal Calibration

1. Hold the mode select button on the side of the transmitter enclosure for about 10 seconds. (See Figure 30.) The transmitter cycles through the set-points and the display starts to blink. Release the mode select button. Input 1 on the communication module goes active. The red LED on the communication module blinks at a 2 Hz rate for 3 seconds while input 1 is active.
2. The communication module calibrate LED flashes at a 1 Hz rate to indicate that it is ready for the zero input. The calibrate bit in the status word is set.
3. The transmitter calibrates the sensor zero value for the 4 ma output.
4. The transmitter display is on steady and input 1 goes inactive.
5. The communication module records the uncalibrated value in the calibration log and calibrates the zero value. The calibrate LED goes on steady.
6. Apply the calibration gas to the sensor.
7. The transmitter display flashes. The communication module calibrate LED blinks at a 1 Hz rate when the input increases.
8. Input 1 goes active when the transmitter input is stable.
9. The communication module records the uncalibrated value in the calibration log.
10. The transmitter completes its calibration. Input 1 goes inactive when the transmitter display is steady. The communication module calibrates the span value and the calibrate LED goes on steady.
11. Remove the calibration gas.
12. The communication module waits until the analog value drops below 4% full scale.
13. The calibration is complete. The calibrate LED goes off and the calibrate bit in the status word is reset.

If the calibration is not completed within 10 minutes, the previous calibration values are restored and the calibration is logged as aborted. The calibrate LED blinks at a 4 Hz rate, the calibrate bit in the status word is reset, and the calibration fault bit in the status word is set.

If the sensor input drops to zero, a fault is signaled and the calibration is aborted. The red communication module LED blinks at a 4 Hz rate, the calibration fault bit is set, and the calibrate bit is reset.

### CAUTION

*If the sensor current should drop to zero during calibration, synchronization between the communication module and the transmitter may be lost, depending on the calibration timing. Resetting the communication module and the transmitter is required, followed by another calibration.*

### Calibration After Sensor Replacement

1. Open the junction box cover and press the sensor replacement switch. Close the cover.
2. The calibrate bit in the status word is set.
3. Replace the sensor and perform a normal calibration.

The communication module will not signal a fault when the input drops to zero due to removal of the sensor. The calibration will not be aborted after 10 minutes.

Calibration values will be stored in the first register.

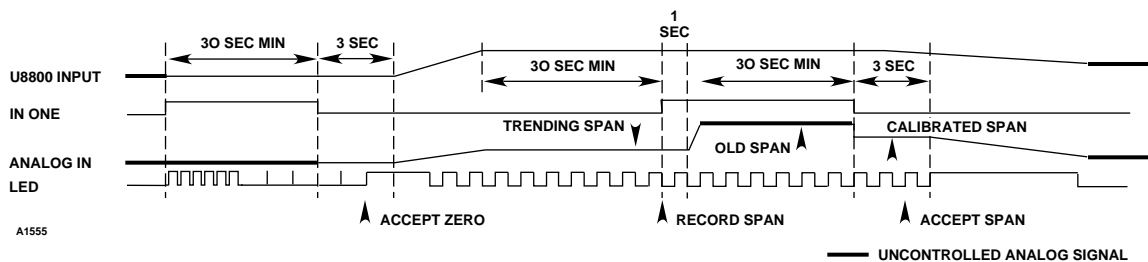

Figure 30—Calibration Algorithm "B"

## CALIBRATION ALGORITHM C (Type Codes 7, 8, 9, 10)

### Normal Calibration

1. Apply the zero gas. (See Figure 31.)
  2. Activate the reed switch or input 1 for at least 4 seconds. The red LED blinks at a 2 Hz rate for 3 seconds while the reed switch is closed.
  3. The calibrate LED on the communication module flashes at a 1 Hz rate, indicating it is ready for the zero input. The calibrate bit in the status word is set.
  4. Wait 4 seconds.
  5. The communication module records the uncalibrated value in the calibration log and calibrates the zero value. The calibrate LED goes on steady.
  6. Apply the calibration gas.
  7. The calibrate LED blinks at a 1 Hz rate when the input increases.
  8. Wait for the sensor input to be stable for 30 seconds.
  9. The communication module records the uncalibrated value in the calibration log and calibrates the span value.
  10. The calibrate LED goes on steady.
  11. Remove the calibration gas.
  12. The communication module waits until the analog value drops below 4% full scale.
  13. The calibration is complete. The calibrate LED turns off and the calibrate bit in the status word is reset.
- If the calibration is not completed within 12 minutes, the previous calibration values are restored and the calibration is logged as aborted. The calibrate LED blinks at a 4 Hz rate, the calibrate bit in the status word is reset, and the calibration fault bit is set.

### Calibration After Sensor Replacement – Combustible Gas

1. Open the junction box cover and press the sensor replacement switch for about 1 second.
2. The calibrate LED on the communication module flashes at a 1 Hz rate, indicating it is ready for the zero input. The calibrate bit in the status word is set.
3. Switch the transmitter to calibrate and connect a voltmeter to the test points.
4. Replace the sensor and wait 5 minutes for the sensor output to stabilize.
5. Adjust the zero output for 0.40 vdc (4 ma).
6. Switch the transmitter to normal to set the sensor analog zero.
7. Activate the reed switch or input 1 on the communication module for 4 seconds. The red LED blinks at a 2 Hz rate for 3 seconds while the reed switch is closed.
8. The communication module records the uncalibrated value in position one of the calibration log and calibrates the zero value. The calibrate LED goes on steady.
9. Switch the transmitter to calibrate.
10. Apply the calibration gas and wait for the output to stabilize.
11. Adjust the span to 1.2 vdc (12 ma) if 50% LFL gas is used.
12. Switch the transmitter to normal to set the sensor analog span value. The red LED blinks at a 1 Hz rate when the input goes high.
13. Activate the reed switch or input 1 on the communication module. The red LED blinks at a 2 Hz rate for 3 seconds while the reed switch is closed.
14. The communication module records the uncalibrated value in the first register of the calibration log and calibrates the span value.
15. The calibrate LED goes on steady. Remove the calibration gas and meter and close the cover.
16. The communication module waits until the analog value drops below 4% full scale. The calibration is complete. The calibrate LED turns off and the calibrate bit in the status word is reset.

Pressing the sensor replacement switch aborts the calibration and starts over.

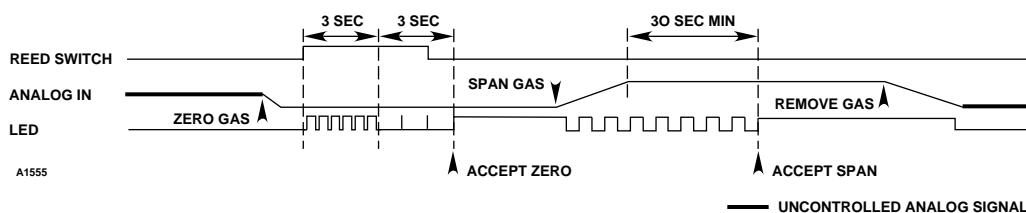

Figure 31—Calibration Algorithm "C"

### Calibration After Sensor Replacement – Toxic Gas

1. Open the junction box cover and press the sensor replacement switch for about 1 second.
2. The calibrate LED on the communication module flashes at a 1 Hz rate, indicating that it is ready for the zero input. The calibrate bit in the status word is set.
3. Replace the sensor and wait 5 minutes for the sensor output to stabilize.
4. Activate the reed switch or input 1 on the communication module. The red LED blinks at a 2 Hz rate for 3 seconds while the reed switch or input 1 is closed.
5. The communication module records the uncalibrated value in position one of the calibration log and calibrates the zero value. The calibrate LED is on steady.
6. Apply the calibration gas.
7. The calibrate LED blinks at a 1 Hz rate when the input increases.
8. Activate the reed switch or input 1 on the communication module. The red LED blinks at a 2 Hz rate for 3 seconds while the reed switch or input 1 is closed.
9. The communication module records the uncalibrated value in the first register of the calibration log and calibrates the span value.
10. The calibrate LED is on steady.
11. Remove the calibration gas and close the cover.
12. The communication module waits until the analog value drops below 4% full scale.
13. The calibration is complete. The calibrate LED turns off and the calibrate bit in the status word is reset.

Pressing the sensor replacement switch aborts the calibration and starts over.

### CALIBRATION ALGORITHM D (Type Codes 11, 12, 13, 14)

#### Normal Calibration

1. Apply clean air (20.9% oxygen). See Figure 32.
2. Activate the reed switch or input 1 for at least 4 seconds. The red LED blinks at a 2 Hz rate for 3 seconds while the reed switch or input 1 is closed.
3. The calibrate LED blinks at a 1 Hz rate, indicating that calibration has begun. The calibrate bit in the status word is set.
4. The communication module waits 3 seconds.
5. The communication module records the uncalibrated value in the calibration log and calibrates the span value.
6. The calibrate LED goes on steady.
7. The communication module waits 3 seconds.
8. The calibration is complete. The calibrate LED turns off and the calibrate bit in the status word is reset.

#### Calibration After Sensor Replacement

1. Open the junction box cover and press the sensor replacement switch.
2. The calibrate LED on the communication module blinks at a 1 Hz rate, indicating that it is ready for the zero input. The calibrate bit in the status word is set.
3. Replace the sensor and set the sensor switch to zero.
4. Activate the reed switch or input 1. The red LED blinks at a 2 Hz rate for 3 seconds while the reed switch or input 1 is closed.
5. The communication module records the uncalibrated value in position one of the calibration log and calibrates the zero value. The calibrate LED is on steady.
6. Set the zero switch on the sensor to normal. Apply clean air (20.9% oxygen) to set the sensor analog span value.
7. The calibrate LED blinks at a 1 Hz rate when the input goes high.
8. Activate the reed switch or input 1 on the communication module. The red LED blinks at a 2 Hz rate for 3 seconds while the reed switch or input 1 is closed.
9. The communication module records the uncalibrated value in the first register of the calibration log and calibrates the span value.
10. The calibration is complete. The calibrate LED turns off and the calibrate bit in the status word is reset.

Pressing the sensor replacement switch aborts the calibration and starts over.

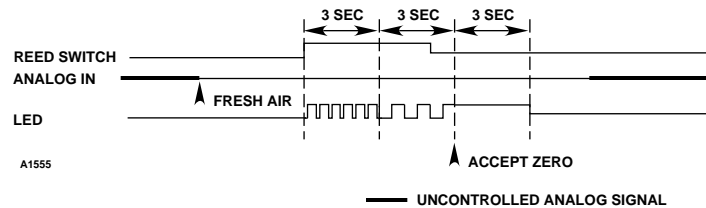

Figure 32—Calibration Algorithm "D"

**CALIBRATION ALGORITHM E  
(Type Codes 23 and 24)**

1. Apply the zero input (4 ma).
2. Activate the reed switch or input 1 on the communication module. (See Figure 33.) The red LED blinks at a 2 Hz rate while the reed switch or input 1 is closed.
3. After the reed switch has been closed for 3 seconds, the calibrate LED on the communication module flashes at a 1 Hz rate, indicating that the calibration has begun. The calibrate bit in the communication module status word is set.
4. The communication module records the uncalibrated value in the calibration log and calibrates the zero value. The calibrate LED goes on steady.
5. When the LED has been on steady for at least 3 seconds, the calibrate LED turns off and the calibrate bit in the status word is reset.

If the calibration is not completed within 12 minutes, the previous calibration values are restored and the calibration is logged as aborted. The calibrate LED flashes at a 4 Hz rate, the calibrate bit in the status word is reset and the calibration fault bit is set.

**CALIBRATION ALGORITHM F  
(Type Codes 15 to 22)**

**Normal Calibration**

1. Activate the reed switch on the communication module. (See Figure 29.) The red LED blinks at a 2 Hz rate while the reed switch is closed.
2. After the reed switch has been closed for 3 seconds, the calibrate LED on the communication module flashes at a 1 Hz rate, indicating that it is ready for the zero input. The calibrate bit in the communication module status word is set.

3. Apply the zero input (4 ma).
4. Activate the reed switch on the communication module. The red LED will blink at a 2 Hz rate while the reed switch is closed.
5. After the reed switch has been closed for 3 seconds, the communication module records the uncalibrated value in the calibration log and calibrates the zero value. The calibrate LED goes on steady.
6. Apply the span input.
7. The calibrate LED blinks at a 1 Hz rate when the input increases.
8. Activate the reed switch on the communication module. The red LED blinks at a 2 Hz rate while the reed switch is closed.
9. The communication module records the uncalibrated value in the calibration log and calibrates the span value.
10. The calibrate LED goes on steady.
11. Remove the span input and return the analog input to normal.
12. Activate the reed switch on the communication module. The red LED blinks at a 2 Hz rate for 3 seconds while the reed switch is closed.
13. The calibration is complete. The calibrate LED turns off and the calibrate bit in the status word is reset.

If the calibration is not completed within 12 minutes, the previous calibration values are restored and the calibration is logged as aborted. The calibrate LED flashes at a 4 Hz rate, the calibrate bit in the status word is reset and the calibration fault bit is set.

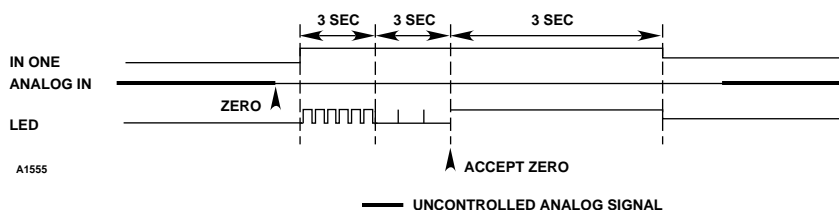

Figure 33—Calibration Algorithm "E"

## Calibration After Sensor Replacement

1. Open the junction box cover and press the sensor replacement switch.
2. The calibrate LED on the communication module flashes at a 1 Hz rate, indicating it is ready for the zero input. The calibrate bit in the status word is set.
3. Replace the sensor and apply the zero input (4 ma).
4. Activate the reed switch on the communication module. The red LED blinks at a 2 Hz rate for 3 seconds while the reed switch is closed.
5. The communication module records the uncalibrated value in position one of the calibration log and calibrates the zero value. The calibrate LED goes on steady.
6. Apply the span input.
7. The calibrate LED blinks at a 1 Hz rate when the input increases.
8. Activate the reed switch on the communication module. The red LED blinks at a 2 Hz rate for 3 seconds while the reed switch is closed.
9. The communication module records the uncalibrated value in the first register of the calibration log and calibrates the span value.
10. The calibrate LED goes on steady.
11. Remove the span input and return the analog input to normal.
12. Activate the reed switch on the communication module. The red LED blinks at a 2 Hz rate for 3 seconds while the reed switch is closed.
13. The calibration is complete. The calibrate LED turns off and the calibrate bit in the status word is reset.

Pressing the sensor replacement switch aborts the calibration and starts over. Resetting the communication module will abort sensor replacement.

# Section IX System Maintenance

## ROUTINE MAINTENANCE

To ensure reliable protection, it is important to check and calibrate the system on a regularly scheduled basis. The frequency of these checks is determined by the requirements of the particular installation.

## MANUAL CHECK OF OUTPUT DEVICES

Fault detection circuitry continuously monitors for problems that could prevent proper system response. However, this circuitry does not monitor external response equipment or the wiring to these devices. It is important that these devices be checked initially when the system is installed, as well as periodically during the on-going maintenance program.

## CHECKOUT IN NORMAL MODE

The system should be checked periodically in the Normal mode to ensure that those items not checked by diagnostic circuitry are functioning properly.

### **CAUTION**

*Be sure to secure all output devices that are actuated by the system to prevent unwanted activation of this equipment, and remember to place these same output devices back into service when the checkout is complete.*

## O-RING MAINTENANCE

A rubber O-ring is used to ensure that the junction box cover will seal tightly and provide protection against water ingress. Periodically open the enclosure and check the O-ring for breaks, cracks and dryness. To test the ring, remove it from the enclosure and stretch it slightly. If cracks are visible, it should be replaced. If it feels dry, a thin coating of lubricant should be applied. When re-installing the ring, be sure that it is properly seated in the groove on the housing. It is imperative that this O-ring be properly installed and in good condition. Failure to properly maintain it can allow water to enter the enclosure and cause premature failure. A coating of lubricant should also be applied to the threads on the cover before re-assembling the enclosure. This will both lubricate the threads and help to prevent moisture from entering the enclosure.

### **CAUTION**

*The O-ring should be lubricated with a silicone free polyalphaolefin grease. The use of other lubricants is not recommended, since they can adversely affect the performance of some sensors. Under no circumstances should a lubricant or compound containing silicone be used on systems using catalytic type combustible gas sensors.*

### **SENSOR REPLACEMENT**

Declassify the area or remove power to the detector prior to replacing the sensor in a hazardous area.

To replace the sensor:

1. Remove the cover from the communication module enclosure and press the sensor replacement switch on the circuit board. The calibration bit is set in the status word.

Pressing the sensor replacement switch prevents the communication module from generating a fault signal when the input drops to zero due to removing the sensor. In addition, the calibration will not be aborted if the calibration procedure is not completed within 12 minutes.

2. Replace the sensor or sensing element.
3. Calibrate the sensor using the normal calibration procedure.

### **NOTE**

*Compare part numbers to be sure that the correct replacement sensor is being used.*

### **REPLACEMENT PARTS**

Eagle devices are not designed to be repaired in the field. If a problem should develop, first carefully check for proper wiring, programming and calibration. If it is determined that the problem is caused by an electronic defect, the device must be returned to the factory for repair.

### **NOTE**

*When replacing a device, be sure that the rocker switches on the replacement are the same as the original. Remove power before removing or plugging in the replacement unit. When a communication module or DCU is replaced, the type and configuration codes must be down loaded.*

### **DEVICE REPAIR AND RETURN**

Prior to returning devices or components, contact the nearest local Detector Electronics office so that an RMI (Return Material Identification) number can be assigned. A written statement describing the malfunction must accompany the returned device or component to expedite finding the cause of the failure, thereby reducing the time and cost of the repair. Pack the unit or component properly. Use sufficient packing material in addition to an antistatic bag or aluminum-backed cardboard as protection from electrostatic discharge.

Return all equipment transportation prepaid to the Minneapolis location.

### **OFFICE LOCATIONS**

Detector Electronics Corporation  
6901 West 110th Street  
Minneapolis, Minnesota 55438 USA  
Telephone (612) 941-5665 or (800) 765-FIRE  
Telex 6879043 DETEL UW  
Cable DETRONICS  
Facsimile (612) 829-8750

Detector Electronics Corporation  
13949 Williams Road  
P. O. Box 1329  
Glen Ellen, California 95442 USA  
Telephone (707) 996-0196  
Facsimile (707) 996-0197  
Voice Mail Box Number 930

Detector Electronics Corporation  
466 Conchester Highway  
Aston, Pennsylvania 19014 USA  
Telephone (610) 497-5593  
Facsimile (610) 485-2078

Detector Electronics Corporation  
3000 Wilcrest  
Suite 145  
Houston, Texas 77042 USA  
Telephone (713) 782-2172  
Facsimile (713) 782-4287

Detector Electronics (UK) Limited  
Riverside Park, Poyle Road  
Colnbrook  
Slough, Berkshire  
SL3 OHB  
ENGLAND  
Telephone 01753 683059  
Telex 848124 GRAVIN G  
Facsimile 01753 684540



Det-Tronics France  
La Valette  
Rue du Cimetiere  
78790 Septeuil  
FRANCE  
Telephone 33 1 3497 0650  
Facsimile 33 1 3497 0648

Det-Tronics Deutschland  
Deugra GmbH  
Postfach 1457  
Harkortstrasse 3  
D-4030 Ratingen 1  
GERMANY  
Telephone 49 2102 4050  
Direct 49 2102 405152  
Facsimile 49 2102 405151  
Telex 8589029

Detector Electronics Southern Europe  
Ciodue – FSI  
V.le De Gasperi, 44  
20010 Bareggio (MI)  
ITALY  
Telephone 02 90362148  
Telephone 0336 339748  
Facsimile 02 90361068

Detector Electronics  
108, Sai Prasad Complex  
Opp. Khar Railway Station  
Khar (W)  
Bombay 400 052  
INDIA  
Telephone (91) 22 604 6142  
Facsimile (91) 22 649 7775

Det-Tronics Scandinavia AB  
Costerweg 5  
P O Box 46  
6700 AA Wageningen  
THE NETHERLANDS  
Telephone 31 8370 97625  
Facsimile 31 8370 27308

117333 Moscow  
Gubkina St, d.3  
Gipronii Ran  
Kidde Graviner  
RUSSIA  
Telephone 7 (095) 135 5389  
Facsimile 7 (502) 222 1276

Det-Tronics Scandinavia AB  
Box 81  
S-260 83 Vejbystrand  
SWEDEN  
Telephone 431-53002/53240  
Facsimile 431-52236

Detector Electronics Corporation  
C/O Walter Kidde Aerospace  
143 Cecil Street  
#15-01 G. B. Building  
SINGAPORE 0106  
Telephone (65) 220-1355  
Facsimile (65) 226-16305

Det-Tronics Middle East  
P O Box 44026  
Abu Dhabi  
U.A.E.  
Telephone 971 2 313304  
Facsimile 971 2 393248

Det-Tronics South America.  
AV17 Con Calle 72, No. 71-92  
Apartado 10055  
Maracaibo, VENEZUELA  
Telephone 58-61-521274, -529154, -529749  
Facsimile 58-61-529144  
Telex 61331

Detector do Brasil  
Avenida Geremario Dantas 493  
Rio de Janeiro 22740-011  
BRAZIL  
Telephone (55) 21 392 9633  
Facsimile (55) 21 392 5568

## ORDERING INFORMATION

For assistance in ordering or designing an Eagle system, contact the nearest Detector Electronics office.

When ordering, please specify:

EA2100CG – Eagle Communication Gateway  
EA2200DCU EX – Eagle Digital Communication Unit for combustible gas sensors  
EA2200DCU UNIV – Eagle Digital Communication Unit for toxic gas or oxygen sensors  
EA2200DCU IS – Eagle Digital Communication Unit for intrinsically safe sensors  
EA2300CM – Eagle Communication Module  
EA2400NE – Eagle Network Extender  
EA2500RM – Eagle Relay Module

### MOUNTING RACKS

A Q4004 Mounting Rack is required for installation of the gateway. Q4004 racks can also house gas or flame controllers in any combination. See Figures 22 and 23.

### ACCESSORIES

Magnetic Calibration Tool  
Silicone Free Grease  
Open Frame Power Supply – 3.6 amperes at 24 vdc  
Open Frame Power Supply – 12 amperes at 24 vdc  
W4810 Power Supply mounted in explosion-proof enclosure – 1.0 ampere at 24 vdc

### REPLACEMENT PARTS

| <b>Part Number</b> | <b>Description</b>   |
|--------------------|--|
| 006032-001         | Communication Module without ribbon cable (Communication Module/DCU) |
| 006031-001         | Terminal Board (Communication Module/DCU)                            |
| 006108-001         | Transmitter Board (Combustible gas DCU)                              |
| 006148-001         | Network Extender Circuit Board                                       |
| 006122-002         | 5–1/4 inch Ribbon Cable (DCU)  |
| 101173-023         | 2 inch Standoff (DCU)  |
| 006122-001         | 2–3/4 inch Ribbon Cable (Communication Module)                       |
| 101173-021         | 1.625 inch Standoff (Communication Module)                           |

## REFERENCE LIST

Additional information on Eagle 2000 products is available in the following publications:

Specification Data Sheets:

90-1088 Communication Module  
90-1093 DCU  
90-1089 Network Extender  
90-1097 Relay Module  
90-1090 Gateway

Instruction Manuals:

95-8425 Communication Module  
95-8426 DCU  
95-8430 Network Extender  
95-8423 Relay Module  
95-8433 System Configuration  
95-8453 System Configuration Matrix



**DETECTOR ELECTRONICS CORPORATION**

6901 West 110th Street

Minneapolis, Minnesota 55438 USA

Telephone (612) 941-5665 or (800) 765-FIRE

Facsimile (612) 829-8750

Telex 6879043 DETEL UW

Cable Detronics

Printed in USA

