

Instructions

95-8385-07

Unitized UV/IR Flame Detector
U7652



Table of Contents

DESCRIPTION	1		
oi Feature	2		
Relays and Outputs	2	Figure 1	Detector Orientation Relative to Horizon 5
General Application Information	3	Figure 2	U7652 Front View
INSTALLATION	5	Figure 3	Vertical Mounting
Detector Positioning	5	Figure 4	Detector Junction Box with Cover Removed (Terminal Blocks, Programming Jumpers, Motherboard Assembly
Wiring Requirements	5	Figure 5	Detector Dimensions
Mounting and Wiring Procedure	6	Figure 6	Swivel Mounting Bracket Dimensions ..
Detector Programming	9	Figure 7	U7652B Wiring Terminal Configuration ..
STARTUP AND CHECKOUT PROCEDURE (MANUAL oi TEST)	10	Figure 8	Wiring Terminal Configuration for U7652C with Auxiliary Relay
TROUBLESHOOTING	10	Figure 9	Wiring Terminal Configuration for U7652C with 4 to 20 ma Output
Manual oi Selected	10	Figure 10	A Typical System Using U7652B Detectors
Automatic oi Selected	11	Figure 11	A Typical System Using U7652C Detectors with Auxiliary Relays
Field Testing UV/IR Detectors	11	Figure 12	U7652C Detector with 4 to 20 ma Output Wired for Non-Isolated Current Sourcing Output
Sensor Module Replacement Procedure	13	Figure 13	U7652C Detector with 4 to 20 ma Output Wired for Isolated Current Sinking Output
Motherboard Replacement Procedure	15	Figure 14	Cover Locking Assembly
MAINTENANCE	16	Figure 15	U7652 Detector Parts Identificaiton ..
Viewing Windows/ oi Rings	16	Figure 16	Self Aligning UV Sensor Module
O-Rings	16	Figure 17	IR Module with Four-Wire Connector ..
FEATURES	16	Figure 18	Location of Capacitor for Increased Protection from Ground Transients ..
SPECIFICATIONS	16	Figure 19	UV and IR Spectral Response Range ..
REPLACEMENT PARTS	18	Figure 20	Detector Cone of Vision
DEVICE REPAIR AND RETURN	18		
ORDERING INFORMATION	19		
Accessories	19		
Recommended Spare Parts	19		
APPENDIX A - FACTORY MUTUAL RESEARCH (FMR) APPROVAL DESCRIPTION			

Illustrations

Tables

Table 1	Detector Status Chart	2
Table 2	Current Level for Detector Status (U7652C with 4 to 20 ma Output)	3
Table 3	U7652 Typical Response Distances ..	3
Table 4	UV Absorbing Gases and Vapors	4
Table 5	Programmable Options	10
Table 6	Manual oi Troubleshooting	11
Table 7	Automatic oi Troubleshooting	12



**Unitized UV/IR
Flame Detector
U7652**

NOTE

Not compliant to FM 3260 (2000).

WARNING

Do not open the detector assembly in a hazardous area when power is applied.

CAUTION

- 1. The wiring procedures in this manual are intended to ensure proper functioning of the device under normal conditions. However, because of the many variations in wiring codes and regulations, total compliance to these ordinances cannot be guaranteed. Be certain that all wiring complies with applicable regulations that relate to the installation of electrical equipment in a hazardous area. If in doubt, consult a qualified official before wiring the system.*
- 2. The U7652 contains semiconductor devices that are susceptible to damage by electrostatic discharge. An electrostatic charge can build up on the skin and discharge when an object is touched. Therefore, use caution when handling the detector, taking care not to touch the terminals or electronic components. Observe the normal precautions for handling electrostatic sensitive devices.*
- 3. To minimize the risk of damage, handle the electronic module by the protective cover only. Do not touch the connector, circuit board, or electronic components.*
- 4. Alarm and extinguishing devices should be disconnected before performing the manual **oi** test.*



DESCRIPTION

The U7652 UV/IR Flame Detector is an explosion-proof device that consists of a UV sensor and an IR sensor mounted side-by-side on a junction box. This mounting arrangement allows both sensors to monitor the same hazardous location with a 90 degree cone of vision.

A pair of red LEDs is located inside each sensor viewing window (four LEDs per U7652 Detector). The two LEDs for each sensor are illuminated simultaneously to provide visual annunciation of detector status conditions such as normal operation, fire, fault, UV only, and IR only conditions.

When both sensors simultaneously detect the presence of fire, a fire signal is generated which then actuates a Fire relay and illuminates the sensor LEDs.

Table 1 indicates the condition of the Fire relay, Fault relay, and LEDs for each detector status.

***oi** is Detector Electronics' Trademark for its patented Optical Integrity Systems, U.S. Patent 3,952,196, United Kingdom Patent 1,534,969, Canada Patent 1,059,598.

oi FEATURE

Both sensors are equipped with the Optical Integrity (**oi**) test feature to assure proper operation of the detector by checking the cleanliness of the optical surfaces, sensitivity of the sensors, and proper functioning of the electronic circuitry. No testing with an external test lamp is required. The detector automatically performs the same test that a maintenance person with a test lamp would perform — once every minute, 60 times per hour. A successful automatic **oi** test **does not** produce an alarm condition.

The U7652 can be programmed (using a jumper plug) for automatic and/or manually initiated **oi** testing. Use of automatic **oi** is highly recommended.

Automatic oi

With automatic **oi** selected, the **oi** test is automatically performed on each sensor once every minute. If a fault is detected, the normally energized Fault relay is de-energized and the LEDs on the faulty sensor stop blinking. When automatic **oi** is selected, the detector can also be tested using the manual **oi** test.

Manual oi

The detector also incorporates a manual **oi** feature that provides the same test as the automatic **oi**, and in addition actuates the Alarm relay to verify output operation. The manual **oi** feature is available in all models and can be performed at any time. **This test requires bypass of all extinguishing devices to avoid release resulting from a successful test.**

RELAYS AND OUTPUTS

All U7652 Models

All U7652 Models are furnished with two standard output relays that are rated for 5 amperes (resistive) at 30 vdc.

Fire relay has SPDT (normally open/normally closed) contacts:

- Normally de-energized (no fire).
- Energizes upon detection of fire.
- Field programmable for either latching or non-latching operation.

Fault relay has SPST (normally open) contacts:

- Normally energized (no fault).
- De-energizes when fault is detected.
- Non-latching operation (automatically resets when fault is corrected).

U7652C Model

The U7652C is furnished with either an auxiliary relay or a 4 to 20 ma output in addition to the standard outputs. The U7652C with auxiliary relay requires the presence of radiation at only one sensor for relay actuation-rated for 1 ampere at 30 vdc. (Not recommended for uncontrolled locations.)

Auxiliary relay has SPST (normally open) contacts.

- Field selectable for actuation when “UV radiation only” or “any UV or IR radiation” is detected. (Factory-shipped with the field selectable jumper plug in the “UV only” position.)
- Normally de-energized (selected radiation not detected).
- Energizes upon detection of selected radiation.
- Non-latching when responding to UV only or IR only condition.
- Latches in response to UV and IR radiation at background levels (fire threshold not exceeded).

Table 1—Detector Status Chart

Status	UV LEDs	IR LEDs	Fire Relay	Fault Relay
Normal	Blinking	Blinking	De-energized	Energized
UV Fault	Off	Blinking	De-energized	De-energized
IR Fault	Blinking	Off	De-energized	De-energized
General Fault	Off	Off	De-energized	De-energized
Background UV	On	Off*	De-energized	Energized
Background IR	Off*	On	De-energized	Energized
Fire	On	On	Energized	Energized
Manual oi Test	On	On	Energized	Energized
During normal operation when automatic oi is selected, LEDs blink once every 5 seconds. During normal operation when manual oi is selected, UV and IR sides blink alternately every 5 seconds.				
*Some earlier models will blink under these conditions.				

The U7652C with 4 to 20 ma output uses the dc current level for indicating system status conditions. Table 2 shows the detector status conditions corresponding to each current level.

Data Logger

The optional data logger provides status recording capability for the detector. Important status data such as power-up/down, faults and alarms are date and time stamped as they occur and stored in non-volatile memory. Up to 510 events can be recorded: up to 63 fire alarm events and up to 447 non-fire events. This data is later uploaded to a personal computer (PC) where it can be displayed, saved and/or printed.

The Data Logger system consists of a special electronic module and mother board assembly (one for each U7652 Detector in the system) and a W6300 Detector Inspector™, which provides the interface between the electronic module and the PC.

The W6300 Detector Inspector is furnished with an RS-232 serial port for connection to the serial port of the PC. Communication between the data logger module and the PC uses the Modbus RTU protocol, with the data logger module configured as a Modbus slave.

The Inspector software (included) can operate on most Intel® Pentium® based computers running Microsoft Windows 95/98.

The real time clock in the module is furnished with battery back-up to ensure correct operation in the event of a power failure. The clock provides second, minute, hour, day, month and year data.

The detector's relays and LEDs function exactly the same as the standard U7652 Detector; however, the auxiliary relay and 4 to 20 ma output are not available.

Table 2—Current Level for Detector Status (U7652C with 4 to 20 ma Output)

Current Level*	Detector Status
0 ma	Fault
2 ma	oi Fault
4 ma	Normal Operation
8 ma	IR Only
12 ma	UV Only
16 ma**	Instant Alarm
20 ma	Fire Alarm

* ±0.5 ma

** Available only when 3 second response is selected

GENERAL APPLICATION INFORMATION

Response Characteristics

Table 3 lists the typical response distances of the U7652 Detector to various flammable materials. The detectors were sighted to observe the fire at center axis ±10 degrees and were set for a 0.5 second time delay. Response is dependent on the type of fuel, the temperature of the fuel, and the time required for the fire to build. As with all fire tests, results must be interpreted according to an individual application.

Important Application Considerations

In applying any type of sensing device as a fire detector, it is important to know of any conditions that can prevent the device from responding to fire, and also to know what other sources besides fire can cause the device to respond. Read through the following discussion of these factors before installing the U7652 detectors.

ARC WELDING

The U7652 ignores arc welding beyond 10 feet from the detector. However, the UV sensor will respond to the intense UV radiation generated by the arc welding, and at distances closer than 10 feet the heated metal from the welding can become a false alarm source for the IR sensor. Arc welding should not be performed within 10 feet of the detector.

BLACKBODY SOURCES

Any object with a temperature greater than 0° Kelvin (-273°C) emits IR radiation. The hotter the object, the

Table 3—U7652 Typical Response Distances

Fuel	Distance from U7652
Acetone (1 ft. x 1 ft.)	45 feet (13.7 meters)
Diesel (1 ft. x 1 ft.)	40 feet (12.2 meters)
Gasoline (1 ft. x 1 ft.)	50 feet (15 meters)
JP4, 5, and 8 (2 ft. x 2 ft.)	100 feet (30 meters)
JP4, 5, and 8 (3 ft. x 3 ft.)	150 feet (45 meters)
JP4, 5, and 8 (4 ft. x 4 ft.)	150 feet (45 meters)
JP4, 5, and 8 (10 ft. x 10 ft.)	150 feet (45 meters)
Methane (30-inch plume)	35 feet (10.7 meters)
Methanol (1 ft. x 1 ft.)	35 feet (10.7 meters)
Toluene (1 ft. x 1 ft.)	50 feet (15 meters)
Wood Shavings (One pound excelsior)	50 feet (15 meters)
Wood Stack (10 inch x 10 inch crib)	50 feet (15 meters)

greater the intensity emitted radiation. The U7652 ignores steady state IR sources that do not flicker. However, it should be noted that if these steady state IR sources are hot enough to emit adequate amounts of IR radiation in the response range of the detector and if this radiation becomes interrupted from the view of the detector in a pattern characteristic of a flickering flame, the IR sensor can respond. The closer the IR source is to the detector, the greater the potential for the IR sensor to respond.

AMBIENT RADIATION

The U7652 is designed to reduce false actuations, however, combinations of ambient radiation that could activate both the UV and IR sensor must be avoided. For example, if IR radiation with an intensity that exceeds the fire threshold of the IR sensor should reach the detector as a flickering signal (activating the IR sensor), and if at the same time an electric arc welding signal also reaches the detector (activating the UV sensor), an alarm output will be generated.

NON-CARBON FIRES

The U7652 uses a single frequency IR sensing device with detection limited to the hot CO² emission peak, therefore, it should not be used to detect fires that do not contain carbon, such as hydrogen, sulfur and burning metals without thorough verification testing. Exceptions to this are when the U7652C is used. The U7652C with auxiliary relay can be set to activate to UV only radiation. The U7652C with 4 to 20 ma output has a discrete milliampere output for UV only, allowing it to monitor for UV only radiation.

GASES, VAPORS, SMOKE AND OTHER OBSTRUCTIONS

Radiation must reach the detector in order for it to respond. Keep physical obstructions out of the line of view of the detector. UV or IR absorbing gases or vapors must not be allowed to accumulate between the detector and protected hazard (see Table 4 for a list of these substances). Do not mount the detector close to the ceiling or in other areas where smoke can accumulate.

EMI/RFI INTERFERENCE

The U7652 is resistant to interference by EMI and RFI. It will not respond to a 5 watt walkie-talkie at a distance of greater than 1 foot.

Table 4—UV Absorbing Gases and Vapors

The following 38 substances exhibit significant UV absorption characteristics. These are also generally hazardous vapors. While usually of little consequence in small amounts, these gases can restrict UV detection if they are in the atmosphere in heavy concentrations. It should also be determined whether or not large amounts of these gases may be released as a result of a fire-causing occurrence.

Acetaldehyde	Methyl Methacrylate
Acetone	Alpha-Methylstyrene
Acrylonitrile	Naphthalene
Ethyl Acrylate	Nitroethane
Methyl Acrylate	Nitrobenzene
Ethanol	Nitromethane
Ammonia	1-Nitropropane
Aniline	2-Nitropropane
Benzene	2-Pentanone
1,3 Butadiene	Phenol
2-Butanone	Phenyl Glycide Ether
Butylamine	Pyridine
Chlorobenzene	Hydrogen Sulfide
1-Chloro-1-Nitropropane	Styrene
Chloroprene	Tetrachloroethylene
Cumene	Toluene
Cyclopentadiene	Trichloroethylene
O-Dichlorobenzene	Vinyl Toluene
P-Dichlorobenzene	Xylene

If UV-absorbing gases may be a factor in a given application, precautionary measures should be taken. Detectors can be placed closer to the potential hazard area, and/or the sensitivity of the detection system can be increased. Contact the factory for further details.

Substances such as methane, propane, butane, camphor, hexane and octane are not UV absorbing.

Absorption of infrared radiation in the range of 4.2 to 4.7 microns is not a significant problem with most organic vapors, with the exception of those compounds that have triple bonds such as acetylene, nitriles, silane, or isocyanates. Carbon dioxide concentrations higher than normally present in the atmosphere can also cause substantial loss of fire detection sensitivity.

VIEWING WINDOWS

Keep the detector viewing windows as free of contaminants as possible in order to maintain maximum sensitivity and assure proper operation of the flame detection system (refer to the "Maintenance" section for cleaning instructions). Commonly encountered attenuating substances include, but are not limited to, the following:

- silicones
- oils and greases
- ice buildup
- dust and dirt buildup
- paint overspray.

INSTALLATION

DETECTOR POSITIONING

Detectors should be positioned to provide the best unobstructed view of the area to be protected. The following factors should also be taken into consideration:

- Locate and position the detector so that the fire hazard(s) are within both the field of view and detection range of the device. Refer to Appendix A for specific information.
- Considering the 90 degree cone of vision, use enough detectors to adequately cover the protected area with overlapping cones of vision.
- For fastest response time, position the detectors as close as possible to the anticipated fire source.
- Aim the detector with the anticipated fire source as close as possible to the central axis of the cone of vision.
- If possible, conduct actual flame tests to verify correct detector positioning and proper system operation.
- Position the detector in a manner that will minimize the buildup of contaminants on the viewing window and **oi** ring. Substances such as snow, ice, dirt, oil, paint overspray and numerous other commonly encountered materials are capable of attenuating UV or IR radiation and adversely affecting detector response.

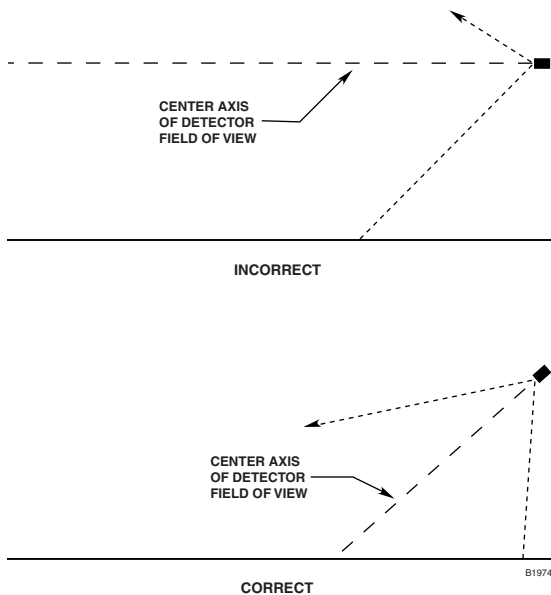

NOTE: DETECTOR MUST ALWAYS BE AIMED DOWNWARD AT LEAST 10 TO 20 DEGREES.

Figure 1—Detector Orientation Relative to Horizon

- For outdoor applications, the detector should be aimed downward at least 10 to 20 degrees to prevent it from scanning the horizon. This minimizes response to distant UV sources outside the protected area. See Figure 1.
- The detector should not be placed where smoke can obscure its view of the hazardous area. For indoor applications, if dense smoke is expected to accumulate at the onset of a fire, mounting the detector on a side wall a few feet (1 meter) down from the ceiling will normally allow enough time for the unit to respond before it is affected by rising smoke.

WIRING REQUIREMENTS

- Use 16 to 22 gauge (1.5 to 0.5 mm²) cable.
- A minimum input voltage of 18 vdc must be present at the detector.
- Use cable that is suitable for the installation environment (harsh environments require specially made cable).
- Shielded cable is highly recommended to protect against interference caused by extraneous electrical “noise.” Foil type shielded cable is recommended to protect from electromagnetic and radio frequency interference. When using cables with shields, the shield should be insulated at the detector and grounded only at the control cabinet.
- When cable is installed in conduit, the conduit should not be used for wiring to other electrical equipment.
- When cable is installed in conduit, the use of conduit seals is required to prevent damage to electrical connections caused by condensation within the conduit. These seals must be watertight and explosion-proof and are to be installed even if they are not required by local wiring codes. A seal must be located as close to the U7652 as possible. In no case should this seal be located more than 18 inches (46 cm) from the unit. If a conduit swivel is used, the seal must be located between the swivel and the detector. When an explosion-proof installation is required, an additional seal must also be installed at any point where the conduit enters a non-hazardous area.
- When cable glands are used, water-proof seals must be fitted between the housing and the gland.
- Position the detector so that the conduit opening is at the bottom or at either side of the device.
- Whenever possible, slope the conduit run downward from the detector. Do not use conduit runs that enter the device from the top. Refer to Figures 2 and 3.

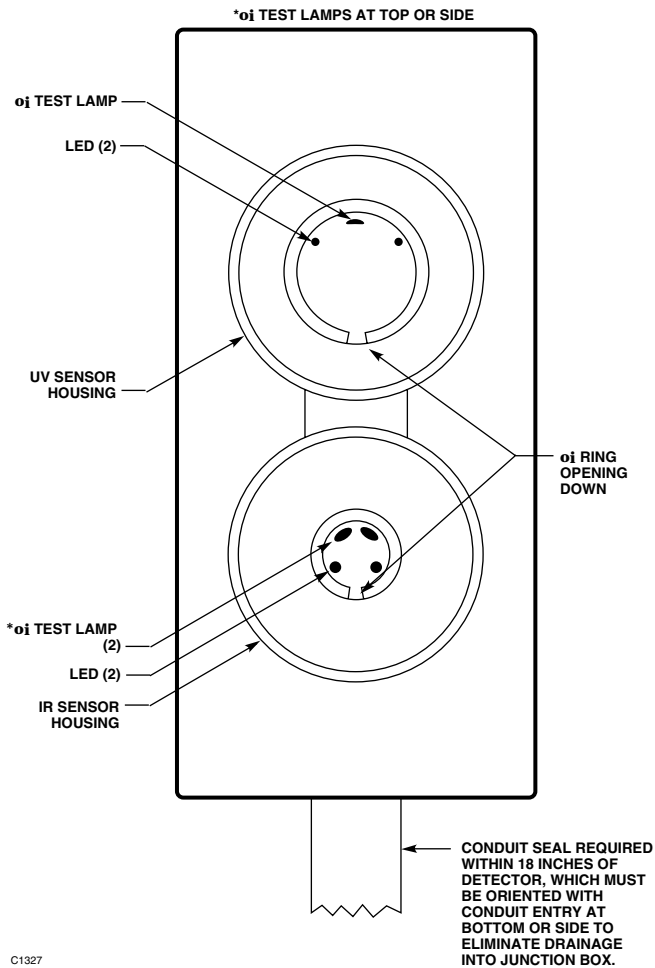
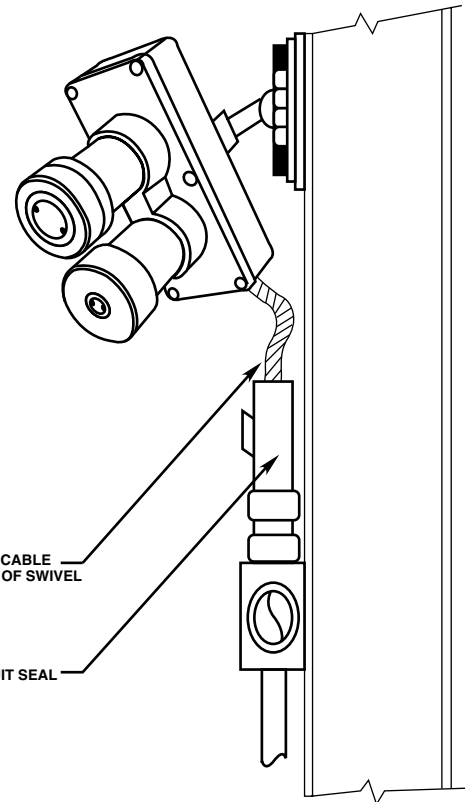

Figure 2—U7652 Front View

C1327

MOUNTING AND WIRING PROCEDURE

The following procedure should be used for mounting and wiring the detector. Refer to the following illustrations:



A1478

Figure 3—Vertical Mounting

Figure 4 — Detector Junction Box with Cover Removed (Terminal Blocks, Programming Jumpers, Motherboard Assembly)

Figure 5 — Detector Dimensions

Figure 6 — Swivel Mounting Bracket Dimensions

Figure 7 — U7652B Wiring Terminal Configuration

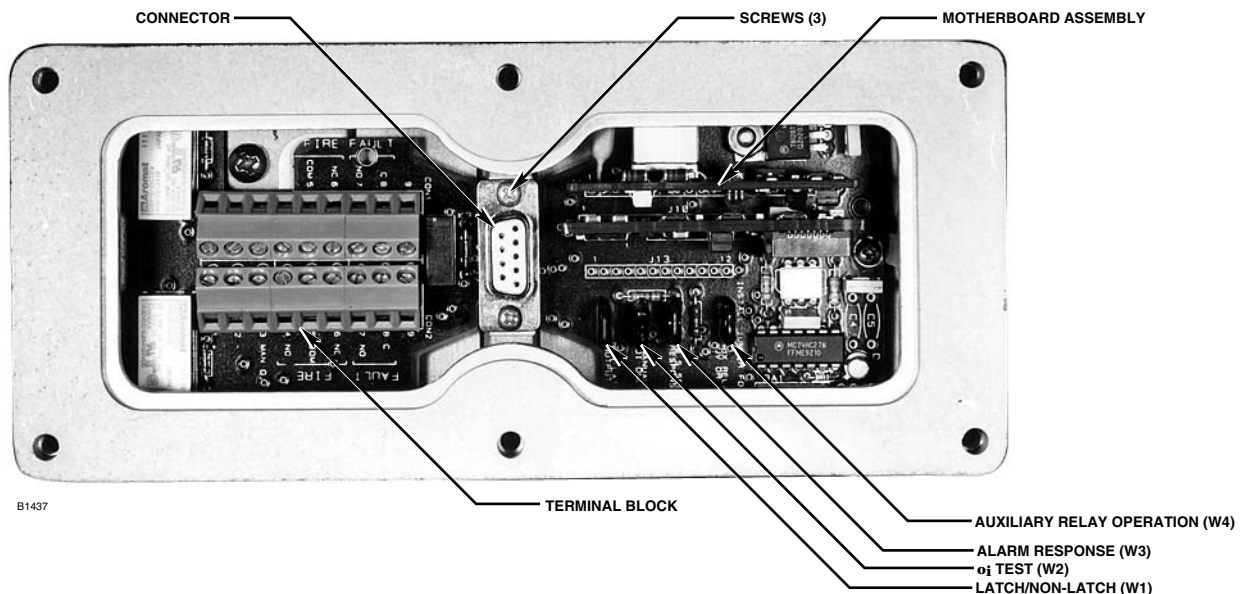

B1437

Figure 4—Detector Junction Box with Cover Removed (Terminal Blocks, Programming Jumpers, Motherboard Assembly)

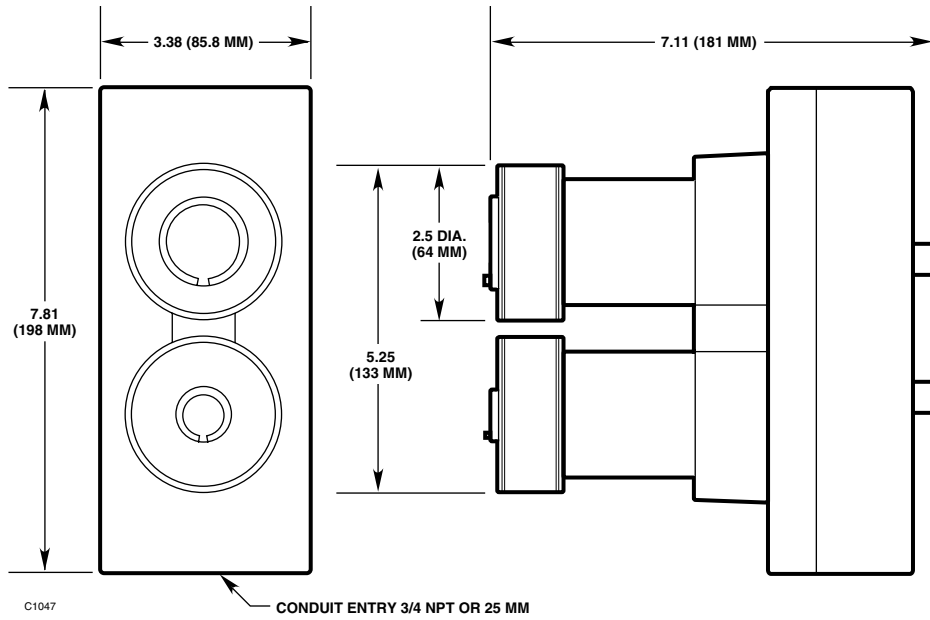

Figure 5—Detector Dimensions

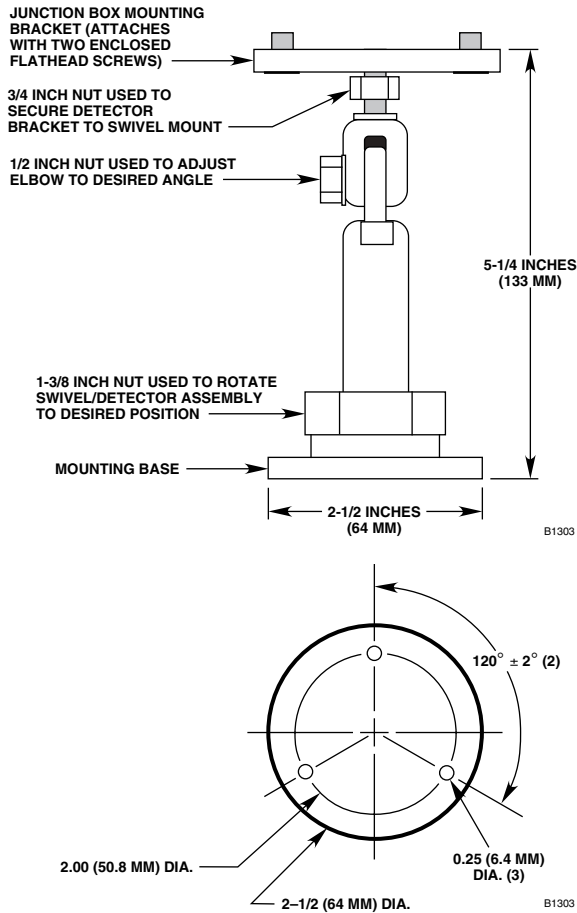

Figure 6—Swivel Mounting Bracket Dimensions

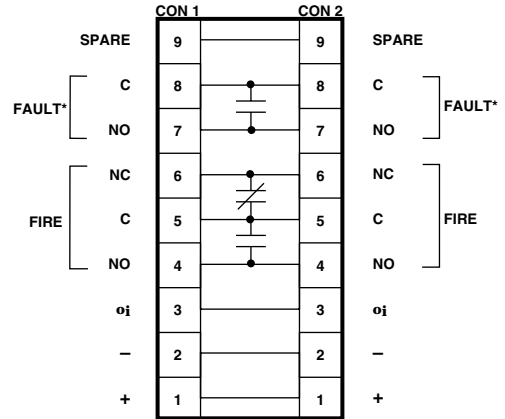

Figure 7—U7652B Wiring Terminal Configuration

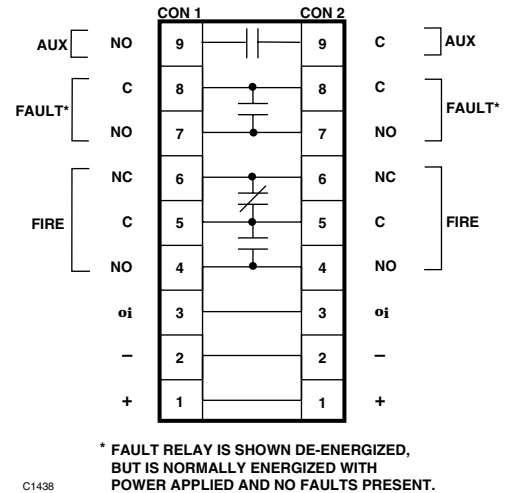
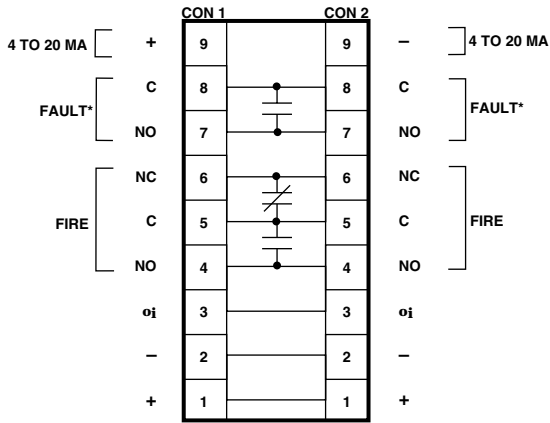

Figure 8—Wiring Terminal Configuration for U7652C with Auxiliary Relay



* FAULT RELAY IS SHOWN DE-ENERGIZED, BUT IS NORMALLY ENERGIZED WITH POWER APPLIED AND NO FAULTS PRESENT.

Figure 9—Wiring Terminal Configuration for U7652C with 4 to 20 ma Output

Figure 8 — Wiring Terminal Configuration for U7652C with Auxiliary Relay

Figure 9 — Wiring Terminal Configuration for U7652C with 4 to 20 ma Output

Figure 10— A Typical System Using U7652B Detectors

Figure 11 — A Typical System Using U7652C Detectors with Auxiliary Relays

Figure 12 — U7652C Detector with 4 to 20 ma Output Wired for Non-Isolated Current Sourcing Output

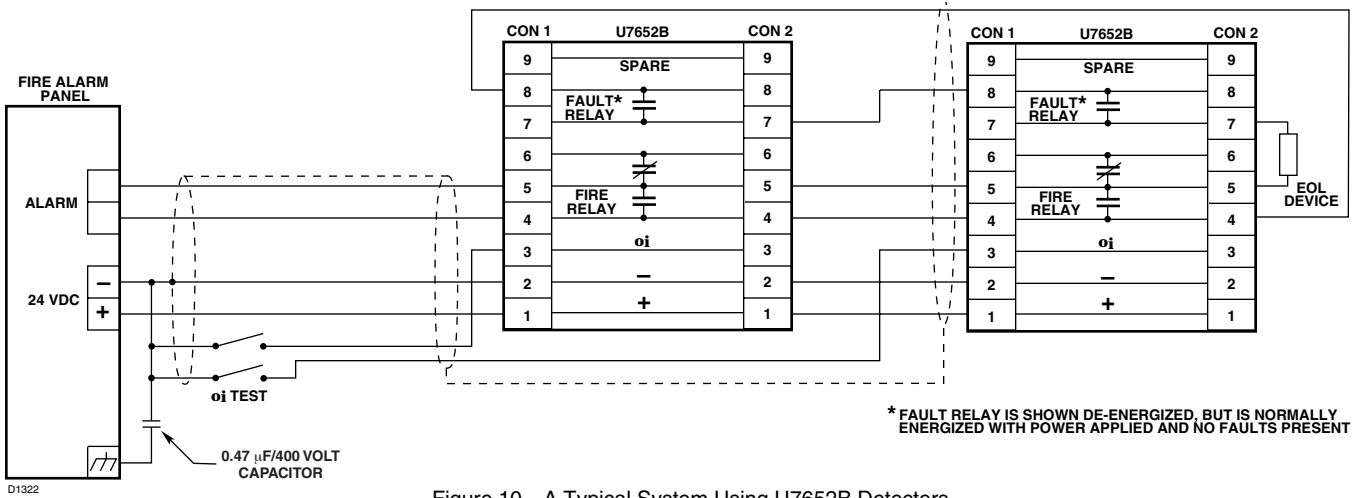

Figure 10—A Typical System Using U7652B Detectors

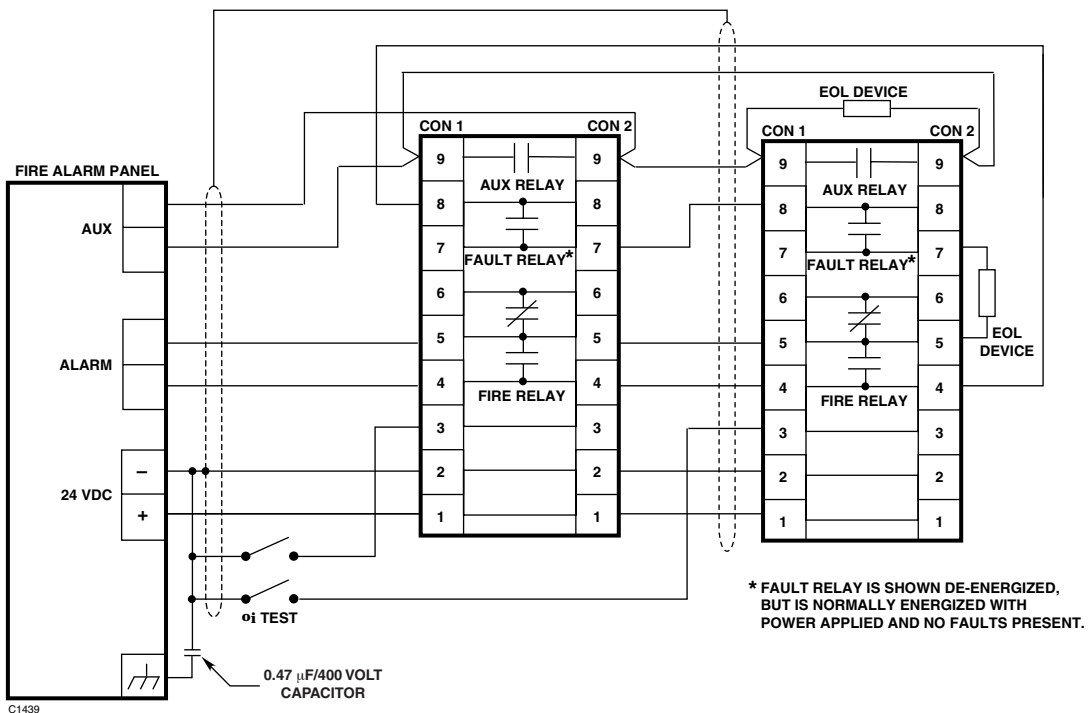

Figure 11—A Typical System Using U7652C Detectors with Auxiliary Relays

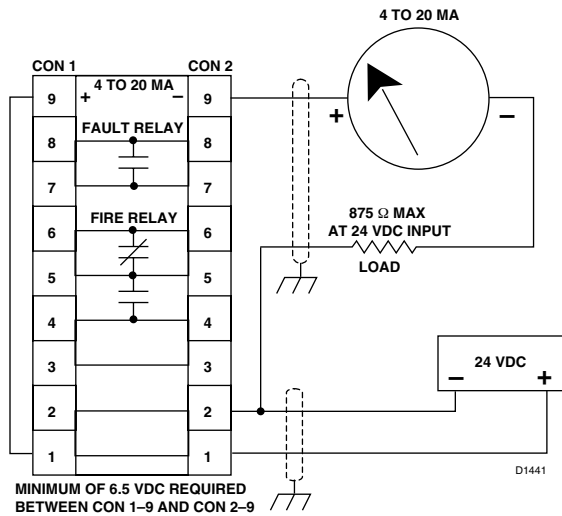

Figure 12—U7652C Detector with 4 to 20 ma Output Wired for Non-Isolated Current Sourcing Output

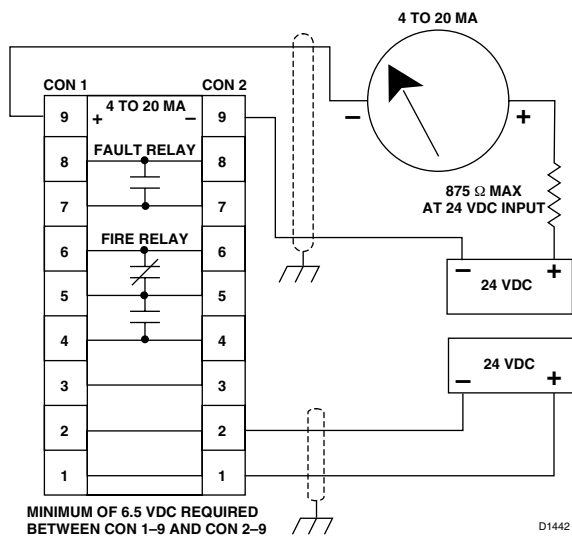

Figure 13—U7652C Detector with 4 to 20 ma Output Wired for Isolated Current Sinking Output

Note that non-isolated operation requires installation of a jumper wire between pins CON 1-1 and CON 1-9 (current sourcing) or between pins CON 2-2 and CON 2-9 (current sinking) on the detector terminal block.

Figure 13 — U7652C Detector with 4 to 20 ma Output Wired for Isolated Current Sinking Output

Note that isolated operation requires the use of a separate power supply.

1. Mount the detector and mounting bracket assembly. The mounting surface should be free of excessive heat and vibration.
2. Remove the junction box cover.

3. Route the field wiring through the detector conduit entry.

4. Connect the leadwires to the appropriate screw terminals on the terminal blocks inside the junction box. Connect the shield to earth ground at the power source. Do not ground the shield at the detector/controller housing (unless required by local codes).

5. If manual **oi** is used, wire the manual **oi** test switches (optional) by connecting a normally open switch, capable of switching 1 ma at 5 vdc and with contact resistance no more than 25 ohms, between the negative (-) side of the dc power source and the terminal marked "**oi**" on the detector terminal block. Each detector should have its own **oi** test switch to allow individual detector testing.

6. Check all field wiring to be sure that the proper connections have been made, and also double check the jumper plugs for correct position. If conduit is used, pour the conduit seals and allow them to dry.

7. Re-install the junction box cover, ensuring that the 9-pin "D" connectors are properly mated between the cover and the circuit board inside the enclosure. The six screws must be tight to ensure a metal-to-metal fit for explosion-proof and watertight integrity of the junction box.

8. Inspect and clean (if necessary) the detector viewing windows and **oi** rings by following the instructions in the "Maintenance" section.

9. Re-install the **oi** rings. The opening should be pointed down to minimize the accumulation of moisture or contaminants behind the ring. Verify that the **oi** test lamp is at the top or side of each sensor.

10. If the detector is so equipped, install the air shields on each sensor housing, then connect the air supply line to the air shields.

DETECTOR PROGRAMMING

The U7652 provides three standard field programmable options:

- 0.5 or 3 second response time
- Latching or non-latching alarm output
- Automatic or manually activated **oi** test.

Table 5—Programmable Options

Pin Location	Function	Jumper Removed	Jumper Installed
W1	Latch/Non-Latch	Latching*	Non-Latching
W2	oi Test	Automatic*	Manual
W3	Alarm Response	3 Second Response*	0.5 Second Response
W4**	Aux. Relay Operation	UV only*	UV or IR

* Factory Setting

** U7652C with Auxiliary Relay Only

In addition, the auxiliary relay in the U7652C can be set for actuation by either “UV radiation only” or “both UV and IR radiation” (indoor applications only).

Detector programming is accomplished using jumper plugs at pin locations W1, W2, W3 and W4 on the printed circuit board located inside the detector junction box. See Figure 4 to locate the pins.

Refer to Table 5 to determine whether the jumper plug should be installed or omitted for a desired option. The detector is furnished from the factory with the jumpers “removed” (the jumper is connected to only one of the two pins). This programs the detector for the following:

- Latching alarm output
- Automatic **oi** testing
- Three second response time.

To change the programming of the detector, remove the junction box cover by loosening the six screws (without power applied), then position the jumpers as desired.

STARTUP AND CHECKOUT PROCEDURE (MANUAL **oi** TEST)

The following procedure should be performed when installation is complete and, at minimum, every six months. More frequent checkouts ensure greater system reliability.

1. Disable any extinguishing equipment that is connected to the system.
2. Apply input power to the system. (Wait ten seconds after applying power before testing the system.)
3. Shine a Det-Tronics model W867 UV/IR test lamp into the viewing window of the detector under test, or press and hold the manual **oi** test button if one has been wired into the system. The Fire relay will energize and the LEDs will be illuminated when the device goes into an alarm condition.

4. Turn off the UV/IR source (or release the **oi** test button). If the unit is programmed for non-latching operation, the Fire relay will become de-energized and the LEDs will turn off when the UV/IR source is removed. If the unit is programmed for latching operation, it can be reset by removing input power (0.1 second minimum).
5. Repeat this test for all detectors in the system. If a unit fails the test, refer to Table 6, Manual **oi** Troubleshooting, for information on correcting the problem.
6. Double check all detectors in the system to be sure that they are properly aimed at the potential hazard.
7. Re-activate all extinguishing equipment that is connected to the system.

TROUBLESHOOTING

Refer to the “Manual **oi** Selected (Jumper W2 Installed)” section below for problems that occur during the “Startup and Checkout Procedure (Manual **oi** Test),” or during normal operation when manual **oi** operation is selected. Refer to the “Automatic **oi** Selected” section below for problems that occur during normal operation when automatic **oi** operation is selected.

IMPORTANT

*To ensure reliable protection, **oi** related faults should be corrected promptly. This is particularly important in environments where oily substances can accumulate on the detector window, potentially blinding the detector.*

MANUAL **oi** SELECTED (Jumper W2 Installed) or Failure During Startup and Checkout Procedure (Manual **oi** Test)

When manual **oi** is selected, the automatically initiated **oi** test is disabled. In normal operation with manual **oi** selected, the sensor LEDs blink alternately at five second intervals.

Table 6—Manual **oi** Troubleshooting

Condition	Indication	Corrective Action
Normal operation with manual oi test not initiated (Manual oi Selected)	Fault relay de-energized LEDs not blinking	Check the operation of the power source and the continuity of the detector wiring. If the detector appears to be “dead” with power applied, remove power and replace the motherboard.
Manual oi Test	Fire relay did not energize and the LEDs of only one sensor are illuminated	The other sensor has failed to respond. <ul style="list-style-type: none"> • Check the cleanliness of the viewing window and repeat the test. • If the sensor fails to respond again, replace the sensor module. • If the sensor still does not respond, replace the motherboard.
Manual oi Test	Fire relay did not energize and the LEDs of neither sensor are illuminated	Both sensors have failed to respond. <ul style="list-style-type: none"> • Check input power and external wiring. • Check the cleanliness of both viewing windows. <p>If the detector still does not respond:</p> <ul style="list-style-type: none"> • If using a test lamp, check the battery, window, etc. to be sure that the test lamp is working properly. • If using the manual oi switch, check the switch for proper operation and wiring. <p>If the detector still does not respond, replace the motherboard.</p>

When manual **oi** is selected, the detector is tested either by pressing and holding the manual **oi** button (if installed) or by shining a W867 Test Lamp into the detector viewing windows. The “Startup and Checkout Procedure (Manual **oi** Test)” section of this manual explains this procedure. For problems encountered during the manual **oi** test, refer to Table 6 - Manual **oi** Troubleshooting.

AUTOMATIC **oi** SELECTED

The Automatic **oi** feature (if selected) tests the detector approximately once each minute, checking the cleanliness of the optical surfaces, sensor sensitivity, and proper functioning of the electronic circuitry. Proper operation of the detector is indicated by simultaneous blinking of both the UV and IR sensor LEDs every 5 seconds. If a problem is detected for three consecutive automatic **oi** tests, a fault signal is generated. If the detector passes three consecutive automatic **oi** tests, the fault signal will then be cleared. If a detector fault is indicated, observe the detector LEDs as well as the status of the detector relays, then refer to Tables 1 and 7 for status and troubleshooting information.

Perform the “Startup and Checkout Procedure (Manual **oi** Test)” in this manual to verify the proper operation of the Fire relay and LEDs.

FIELD TESTING UV/IR DETECTORS

Det-Tronics UV/IR flame detectors contain sensitive electronic components (ICs, transistors, etc.) that can be damaged by electrostatic discharge (ESD). Common causes of damage include improper handling during installation/service, ground faults, power supply transients, and lightning strikes. All Det-Tronics systems are designed with extensive protection circuitry, however, damage can still occur.

The following field test procedure has been developed to test Det-Tronics UV/IR flame detectors for ESD-damaged components:

1. Disable (bypass) all automatic fire extinguishing and shutdown equipment prior to testing. If the detector is part of a Det-Tronics controller-based system, simply move the controller key switch to the Test mode.

Table 7—Automatic **oi** Troubleshooting

Fault	Indication	Corrective Action
UV Fault	<ul style="list-style-type: none"> • Fault relay de-energized • UV sensor LEDs not blinking 	<ul style="list-style-type: none"> • Clean the viewing window and oi ring of the UV sensor. • Check the oi ring opening for proper orientation. See Figure 2. <p>If the fault does not clear (UV fault reoccurs after approximately 3 minutes):</p> <ul style="list-style-type: none"> • First replace the UV sensor module. • If the problem persists, contact the factory.
IR Fault	<ul style="list-style-type: none"> • Fault relay de-energized • IR sensor LEDs not blinking 	<ul style="list-style-type: none"> • Clean the viewing window and oi ring of the IR sensor. • Check the oi ring opening for proper orientation. See Figure 2. <p>If the fault does not clear (IR fault re-occurs after approximately 3 minutes):</p> <ul style="list-style-type: none"> • Check the connection and condition of the IR module connector plug and wires. Repair or replace if needed • If the problem persists, replace the IR sensor module. • If the problem still persists, contact the factory.
General Fault	Fault relay de-energized LEDs not blinking	<p>Check input power to the detector as well as continuity of system wiring.</p> <p>Also check the detector viewing windows for contamination such as paint overspray, dirt, etc. that could simultaneously affect both sensors. Since simultaneous failure of both sensor modules is unlikely, the problem is most likely caused by loss of input power or failure of the detector motherboard.</p>
Background Radiation	The presence of background UV or IR radiation is indicated by steady illumination of the LEDs at either of the sensors. The Fault and Fire relays are unaffected.	<p>Background radiation as such does not cause a problem with the detector in most applications, unless both UV and flickering IR non-fire radiation sources occur simultaneously. If a UV or IR background radiation indication occurs:</p> <ul style="list-style-type: none"> • Determine its cause. The presence of background radiation could indicate a problem in the protected area. For example, background UV could be caused by welding. • Determine whether or not repositioning the detector could eliminate response to the background radiation without reducing coverage of the hazardous area. • If the UV or IR LEDs are on and it is determined that no background UV or IR source exists (by shielding the view of the detector), the problem could be in the sensor module, motherboard assembly or detector wiring.
IR Fault upon Power-up	<ul style="list-style-type: none"> • Fault relay de-energized • IR sensor LEDs on continuously 	<p>The detector will function in this condition. However, it is essentially functioning as a UV only detector, since the IR sensor is continuously sending a fire signal. A fire signal will override a fault signal. This can make the detector more susceptible to false alarms caused by non-fire UV radiation sources such as welding. If the IR sensor returns to normal operation (no longer in an alarm condition), the microprocessor will recognize this and the fault will be cleared. If not, the usual corrective action is replacement of the IR sensor module.</p>

2. To verify proper IR sensor operation, expose each operating UV/IR detector to the ultraviolet energy from the model W8066 UV test lamp. The model W867 UV/IR test lamp also may be used by first completely covering the IR sensor portion of the detector with solid material, and then exposing only the UV portion of the detector to the output of the W867 test lamp. Ensure that the test lamp is within one (1) meter of the detector, and aimed directly at the center of the detector lens. Proof of a successful test is **no fire alarm** output from the detector. Any UV/IR detector that does respond to only UV radiation may have a faulty IR module and will require further inspection. Note that some Det-Tronics UV/IR detectors will provide a UV-only alarm that must not be confused with the fire alarm output.
3. To verify proper UV sensor operation, completely cover only the UV sensor and then expose the IR sensor to the output from the W867 UV/IR test lamp. Proof of a successful UV test is **no fire alarm** output from the detector. Ensure that the W867 UV/IR test lamp is within one (1) meter of the detector. **Do not** use the model W8066 UV test lamp for this test.
4. Finally, expose each operating, uncovered UV/IR detector to the output of the model W867 UV/IR test lamp to re-confirm fire detection capability. Ensure that the W867 UV/IR test lamp is within one (1) meter of the detector, and verify that the detector **does** provide a fire alarm output.

If a damaged detector sub-assembly in the field has been identified, exchange it with a different sub-assembly from a known good detector, then re-assemble and re-test until proper operation is observed. If abnormal operation is evident, start with the sensor exchange first, then the detector cover assembly, and finally the detector mother board assembly. Always remove system power before servicing any detector, and always ensure that proper electrostatic grounding procedures are followed before handling.

Return any damaged sub-assemblies or detectors to the Det-Tronics Service Center for inspection and repair. Please call for a return material identification number before returning equipment to the factory.

SENSOR MODULE REPLACEMENT PROCEDURE

To replace a defective module:

CAUTION

Do not open the detector housing in a hazardous location without first removing power, including power to the relay contacts.

1. Remove power from the detector and relay contacts.
2. If the detector is equipped with cover locking devices (see Figure 14), loosen the clamp and disengage the “catch” from the blind hole for the appropriate sensor.
3. Remove the sensor housing (see Figure 15).
4. Remove the defective sensor module.
5. Determine the proper orientation for the new sensor module (with the **oi** test lamps positioned at the top or side of the detector), then install the module.

- For the UV module (Figure 16), line up the longest banana plug on the terminal block with the hole in the printed circuit board of the module. See Figure 15. Firmly press the module into place on the terminal block, taking care not to touch the glass envelope of the sensor module. If the UV sensor module is supplied with a jumper plug “J,” remove the jumper plug from the detector tube module and discard it. Jumper plug “J” is supplied for installations in which the tube module is used with other detector models.

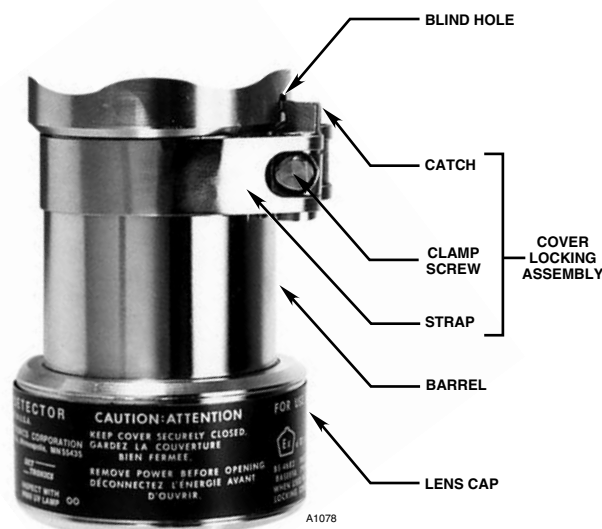

Figure 14—Cover Locking Assembly (Optional)

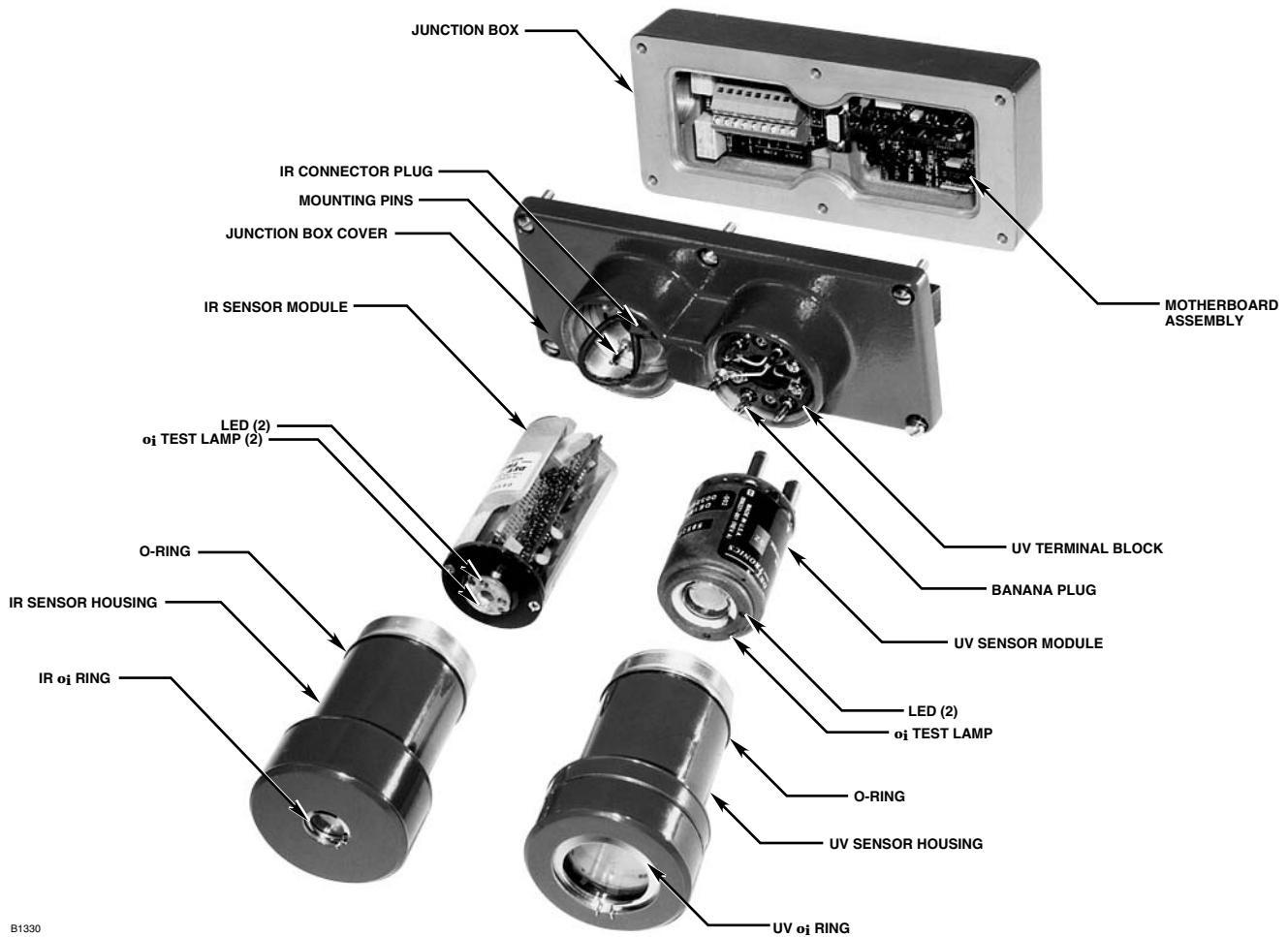

Figure 15—U7652 Detector Parts Identification

- For the IR module, thread the wire leads and keyed connector plug through the slotted opening on the side of the IR module. Plug the IR module into the two banana plugs inside the junction box cover (Figure 17). Connect the keyed plug to the 4-pin connector on the IR module. Tuck the leadwires inside the module to prevent binding or wire damage.
6. Ensure that the O-rings at the base of the sensor housing are positioned correctly and are in good condition. (Refer to the “Maintenance” section for complete information regarding care of O-rings.)
 7. Re-install the sensor housing. Hand tighten the sensor housing into the base until the O-ring is fully seated.
 8. Re-install the cover locking device (if used).
 9. Inspect the viewing windows and **oi** rings and clean if necessary. Also check the position of the **oi** rings (refer to Figure 2).
 10. Perform the “Startup and Checkout Procedure (Manual **oi** Test)” as described in this manual before returning the system to normal operation.



Figure 16—Self Aligning UV Sensor Module

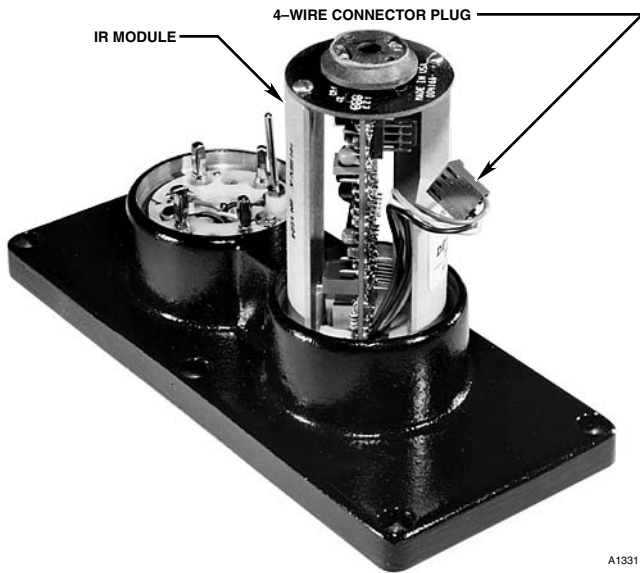

Figure 17—IR Module with Four-Wire Connector

2. Loosen the six screws and remove the junction box cover (see Figure 15).
3. Disconnect all field wiring from the detector terminal blocks. Note all wire locations to assure proper reconnection. See Figure 4.
4. Remove the three screws that secure the motherboard assembly to the inside of the junction box. Remove the motherboard.
5. Note the position of the jumper plugs on the motherboard that is being replaced, then install the jumpers on the new motherboard in the same positions.
6. Install the new motherboard inside the junction box and tighten the three screws. If not already installed, a capacitor may be installed as shown in Figure 18 to improve resistance to ground transients.
7. Re-connect all field wiring to the detector terminal blocks.
8. Apply a small amount of lubricant to each of the six screws on the junction box cover. Line up the “D” connector on the junction box cover with the connector on the motherboard, then re-install the cover and tighten the six screws sufficiently to ensure a metal-to-metal fit for explosion-proof and watertight housing integrity.

MOTHERBOARD REPLACEMENT PROCEDURE

To replace a defective motherboard:

CAUTION

Do not open the detector housing in a hazardous location without first removing power, including power to the relay contacts.

1. Remove power from the detector and relay contacts.

U7652 UV/IR DETECTOR WITH COVER REMOVED

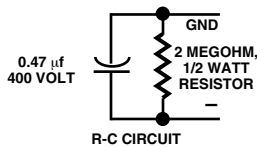
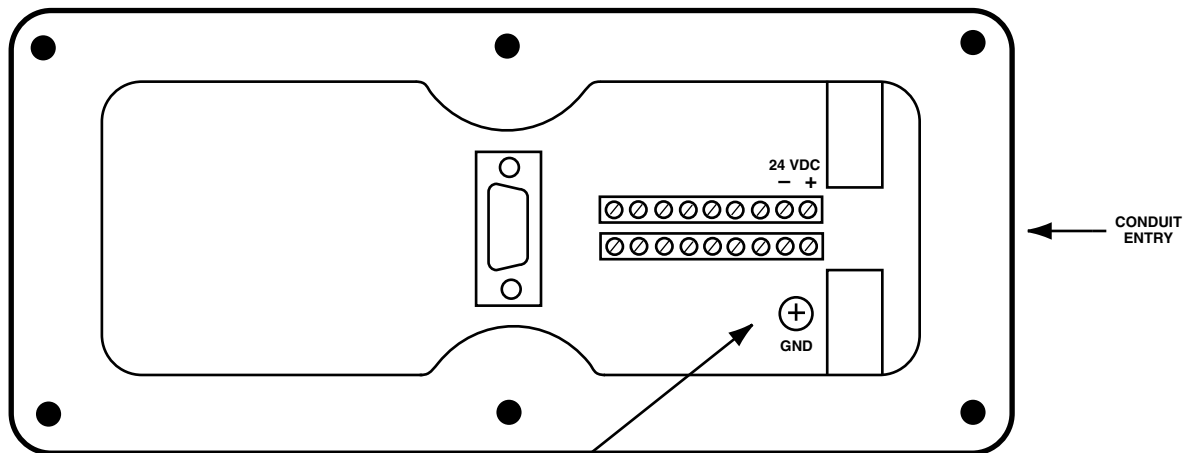

- NOTES
- THIS ENHANCEMENT IS INSTALLED ON ALL NEW U7652 DETECTORS. IT IS RECOMMENDED THAT THIS ENHANCEMENT BE INSTALLED IN ALL EXISTING MODELS TO PROVIDE INCREASED EMI PROTECTION.
 - PARTS REQUIRED: 0.47 MICROFARAD, 400 VOLT CAPACITOR AND A 2 MEGOHM, 1/2 WATT RESISTOR.
 - TERMINATE THE RESISTOR-CAPACITOR PARALLEL CIRCUIT BETWEEN THE DC COMMON RETURN TERMINAL AND THE EARTH GROUND SCREW.
 - ENSURE THAT ALL SOLDER CONNECTIONS AND BARE CONDUCTORS ARE PROPERLY GROUNDED.
 - IF USING GROUND FAULT MONITORING, CUT THE RESISTOR OUT.

Figure 18—Location of Capacitor for Increased Protection from Ground Transients

9. Perform the “Startup and Checkout Procedure (Manual **oi** Test)” as described in this manual before returning the system to normal operation.

MAINTENANCE

VIEWING WINDOWS/**oi** RINGS

The U7652 Detector requires no periodic calibration. However, to maintain maximum sensitivity, the detector viewing windows must be kept clean at all times.

NOTE

Remove input power when cleaning the detector windows. The rubbing motion on the surface of the windows during cleaning can create static electricity that could result in unwanted output activation.

To clean the optical surfaces, remove the **oi** rings from the detector by gently squeezing the tabs together and then pulling out. Clean the viewing windows and the back side of the **oi** rings using a clean cloth or tissue and Det-Tronics window cleaning solution. Avoid leaving fingerprints on the reflective surfaces of the **oi** rings. Re-install the rings so that the openings are pointed down to prevent a buildup of contaminants. If corrosive contaminants in the atmosphere cause the reflective rings to deteriorate to the extent that it is no longer possible to restore them to their original condition, they must be replaced.

O-RINGS

Rubber O-rings on each of the detector base housings are used to ensure the watertight integrity of the detector. Periodically, the housing should be opened and the O-rings inspected for breaks, cracks, and dryness. To test them, remove the rings from the detector housing and stretch them slightly. If cracks are visible, the ring should be replaced. If they feel dry to the touch, a thin coating of lubricant should be applied. When re-installing the rings, be sure that they are properly seated in the groove on the housing. It is imperative that these O-rings be properly installed and in good condition. Failure to maintain these rings can allow water to enter the detector and cause premature failure.

Use a silicone free polyalphaolefin grease (available from Detector Electronics) to lubricate the O-rings. A thin coating of lubricant should also be applied to the threads on the sensor housings before reassembling the detector.

FEATURES

- Detector and controller housed in a single unit.
- Responds to 1 x 1 foot gasoline fire at 50 feet.
- Responds to fire even when UV or IR false alarm sources are present.
- Relay outputs for fire and fault signals.
- Optional 4 to 20 ma output available.
- Optional auxiliary relay available that responds to either “UV radiation only” or to “any UV or IR radiation.”
- Optional Data Logger available.
- Selectable latching or non-latching alarm output.
- Selectable 0.5 or 3 second response time.
- LEDs indicate normal operation, fire, fault, UV only and IR only conditions.
- Selectable automatic and/or manually initiated **oi** test.
- Microprocessor controlled.
- Fire and fault algorithms ensure reliability.
- Watchdog timer monitors the operation of the program.
- Modular design allows easy field replacement of sensor modules.
- Surface mount technology printed circuit board assemblies.
- Suitable for Style D (Class A) wiring.
- RFI/EMI hardened - meets MIL STD 461, 462 and 463.
- Solar blind and immune to most commonly encountered false alarm sources.
- Explosion-proof enclosure is FM approved, CSA certified, and CENELEC certified.

SPECIFICATIONS

OPERATING VOLTAGE—

24 volts dc nominal, 18 volts dc minimum to 32 volts dc maximum.

MAXIMUM RIPPLE—

Ripple should not exceed 5 volts peak to peak. The sum of dc plus ripple must be ≥ 18 vdc and ≤ 32 vdc.

OPERATING POWER—

2.0 watts nominal, 5.0 watts maximum.

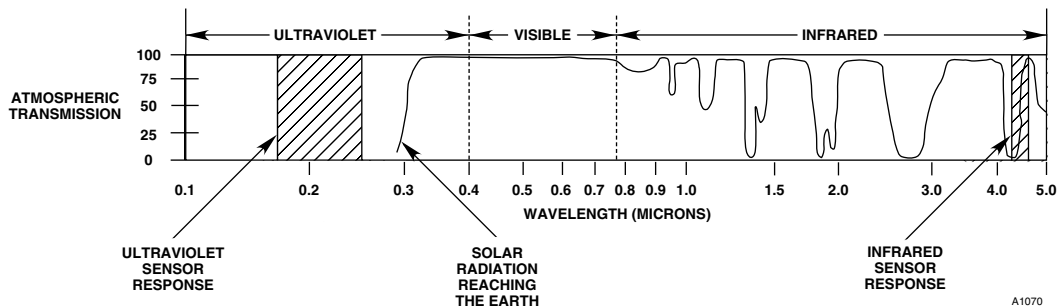

Figure 19—UV and IR Spectral Response Range

SPECTRAL SENSITIVITY RANGE—

UV: 0.185 to 0.245 micron.
 IR: 4.45 microns.

Figure 19 illustrates the spectral response range of the UV and IR sensors.

CONE OF VISION—

The detector has a nominal 90 degree cone of vision with the highest sensitivity along its central axis. See Figure 20.

SENSITIVITY—

The U7652 detects a 1 foot by 1 foot gasoline fire at 50 feet, a 2 foot by 2 foot JP4, 5, or 8 fire at 100 feet, and a 3 foot by 3 foot JP4, 5, or 8 fire at 150 feet.

RESPONSE TIME—

Response time is a function of fuel, fire size, distance and orientation of the fire. The detector is field programmable (using a jumper plug) for a 0.5 or 3 second response time when exposed to a saturating fire signal.

RELAY CONTACT RATING—

One Fire and one Fault relay, each rated 5 amperes (resistive) at 30 vdc. The Auxiliary relay in the U7652C is rated 1 ampere at 30 vdc. The Fire and Auxiliary relays are field programmable for latching or non-latching operation. In latching operation the relay is reset by removing operating power for 0.1 second.

ENCLOSURE MATERIAL—

Copper-free aluminum (red) or 316 stainless steel, with stainless steel mounting bracket.

TEMPERATURE RATING—

Operating: -40°F to +167°F (-40°C to +75°C).
 Storage: -40°F to +185°F (-40°C to +85°C).

HUMIDITY RANGE—

0 to 95% RH. Can withstand 100% condensing humidity for short periods of time.

CERTIFICATIONS—

FMR: See Appendix A for details.

CSA: Class I, Division 1, Groups B, C and D;
 Class I, Division 2, Groups A, B, C and D (T4A).
 Class II/III, Division 1, Groups E, F, and G;
 Class II/III, Division 2, Groups F and G (T4A).
 Enclosure Type 4X

ULC: Explosion-proof for Class I, Division 1, Groups C and D.
 Dust ignition-proof for Class II, Division 1, Groups E, F, and G.

100% REPRESENTS THE MAXIMUM DETECTION DISTANCE FOR A GIVEN FIRE. THE SENSITIVITY INCREASES AS THE ANGLE OF INCIDENCE DECREASES.

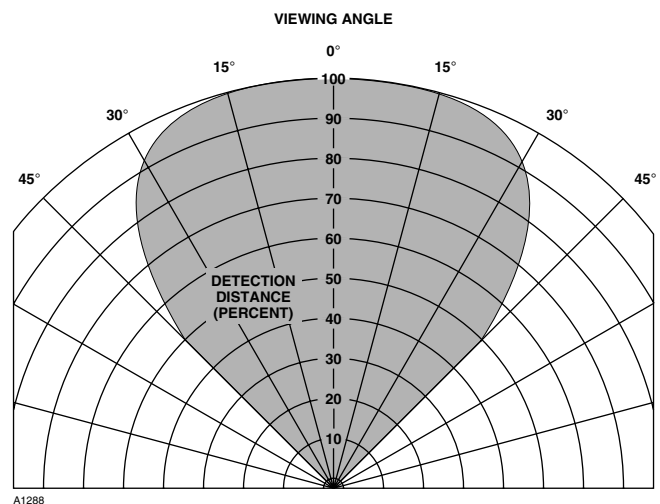

Figure 20—Detector Cone of Vision (Gasoline)

CENELEC: Standard temperature version:
 EEx d IIB +H₂ T6
 (T_{amb} = -40°C to +75°C).
 EEx d IIB +H₂ T5
 (T_{amb} = -40°C to +90°C).
 Extended temperature version:
 EEx d IIB +H₂ T6
 (T_{amb} = -55°C to +75°C).
 EEx d IIB +H₂ T5
 (T_{amb} = -55°C to +90°C).
 EEx d IIB +H₂ T4
 (T_{amb} = -55°C to +125°C).

IP66.

Special Conditions for Safe Use (“X”)

The UV detector module contains a fused silica lens which can be damaged by impact. The detector should be installed in such a manner as to prevent the lens from receiving mechanical damage.

Russian Certification:
 Performance verified from
 -55°C to +75°C.
 1Ex d IIB T6X (T_{amb}=-40°C to +75°C).
 IP66.

VIBRATION—

Meets MIL STD 810C, method 514.2, procedure X, curve AW (6 to 200 Hz, 1.5 g).

RFI/EMI HARDENED—

Meets RFI and EMI immunity requirements for MIL-STD 461, 462 and 463.

INGRESS PROTECTION—

NEMA/Type 4X (Indoor and outdoor use).
 IP66.

WIRING—

16 to 22 AWG. As with any electronic device, shielded cable provides increased RFI and EMI immunity. A 3/4 inch NPT conduit entry is provided on FM and CSA models; a 25 mm conduit/cable entry is provided on CENELEC models.

DIMENSIONS—

See Figures 5 and 6.

MTBF—

36,183 hours.

SHIPPING WEIGHT (Approximate)—

	Pounds	Kilograms
Aluminum housing	6.0	2.7
Stainless steel housing	14.0	6.3

REPLACEMENT PARTS

The electronic module is not designed to be repaired in the field. If a problem should develop, first carefully check for proper wiring and switch setting. If it is determined that the problem is caused by an electronic defect, the device must be returned to the factory for repair.

NOTE

When replacing an electronic module, be sure that the rocker switches of the replacement are set the same as the original. Remove power before removing the housing cover from the detector or plugging in the replacement module.

DEVICE REPAIR AND RETURN

Prior to returning devices or components, contact the nearest local Detector Electronics office so that a Service Order number can be assigned. A written statement describing the malfunction must accompany the returned device or component to expedite finding the cause of the failure.

Pack the unit or component properly. Use sufficient packing material in addition to an anti-static bag or aluminum-backed cardboard as protection from electrostatic discharge.

Return all equipment transportation prepaid to the factory in Minneapolis.

ORDERING INFORMATION

When ordering, specify:

U7652B UV/IR Detector
U7652C UV/IR Detector with Auxiliary Relay
U7652C UV/IR Detector with 4 to 20 ma output

Detector housing materials:

- Copper-free red painted aluminum
- 316 Stainless steel

Cover locking assembly (CENELEC certified equipment only). Two locking assemblies are required per detector. Refer to Figure 14.

ACCESSORIES

Q9001G7001 Swivel Mount Assembly is recommended for mounting the detector.

Q1113 Air Shield Assembly is intended for use in locations with high levels of airborne contaminants. Two air shield assemblies are required per detector.

W867 Explosion-proof UV/IR Test Lamp allows convenient on-site testing of the detector without the need for an open flame.

W8067 Non Explosion-proof UV/IR Long Range Test Lamp

RECOMMENDED SPARE PARTS

o i ring for UV detector	1 per 10 units
o i ring for IR detector	1 per 10 units
O-rings for UV and IR detectors	2 per 10 units
UV module with LEDs	1 per 10 units
IR module with LEDs	1 per 10 units
Motherboard for U7652B	1 per 10 units
Motherboard for U7652C with Auxiliary Relay	1 per 10 units
Motherboard for U7652C with 4 to 20 ma output	1 per 10 units
Window Cleaner Squeeze Bottle (6)	1 per 10 units
UV/IR Window Maintenance Kit	1 per 40 units
Grease for O-rings	1 per 10 units
Capacitor (for increased protection from ground transients)	1 per 10 units
Lubrication (for junction box cover screws)	1 per 50 units

For assistance in ordering a system to fit your application, please contact:

Detector Electronics Corporation
6901 West 110th Street
Minneapolis, Minnesota 55438 USA
Operator: (952) 941-5665 or (800) 765-FIRE
Customer Service: (952) 946-6491
Fax: (952) 829-8750
Web site: www.detrronics.com
E-mail: detrronics@detrronics.com

APPENDIX A - FACTORY MUTUAL RESEARCH (FMR) APPROVAL DESCRIPTION

APPROVAL

Models U7652B (relay output) and U7652C (relay or 4-20 ma output) with aluminum or stainless steel enclosure and 1/2-inch NPT conduit entries (M25 conduit entry may be used in non-North American applications). For 18-32 vdc operation through an approved control panel that provides separate circuits for power and alarm initiation.

- Automatic Fire Alarm Signaling Performance verified per FM3260.
- Explosionproof for Class I, Division 1, Groups B, C and D Hazardous (Classified) Locations per FM 3615.
- Dust-ignitionproof for Class II/III, Div. 1, Groups E, F, and G Hazardous (Classified) Locations per FM 3615.
- Non-incendive for Class I, Division 2, Groups A, B, C and D (T4A); Class II/III, Division 2, Groups F and G (T4A) Hazardous (Classified) Locations per FM 3611.
- Ambient Temperature Limits –40°C to +75°C.
- Enclosure Rating NEMA/Type 4X per NEMA 250.
- Performance verified Optical Integrity (**oi**).
- The following performance criteria was verified by FMR using IR Module DE 5400-001 and UV Module DE1888:

Response Characteristics

Time Delay	Fuel	Size	Distance	Average Response Time
0.5 sec.	Gasoline	1 ft x 1 ft (0.3 m x 0.3 m)	50 ft (15 m)	within 2 sec.
3 sec.	Gasoline	1 ft x 1 ft (0.3 m x 0.3 m)	50 ft (15 m)	within 10 sec.
0.5 sec.	JP-4	2 ft x 2 ft (0.6 m x 0.6 m)	100 ft (30.5 m)	within 2 sec.
0.5 sec.	JP-4	4 ft x 4 ft (1.2 m x 1.2 m)	150 ft (45.7 m)	within 2 sec.
0.5 sec.	JP-4	10 ft x 10 ft (3.0 m x 3.0 m)	150 ft (45.7 m)	within 2 sec.

Angle of View

–45 to +45 off centerline in vertical and horizontal planes.

False Alarm Immunity

- Direct Sunlight
- A 150 watt incandescent lights at 2 ft. (0.6 m).
- Two 60 watt fluorescent at 2 ft. (0.6 m).
- A 500 watt halogen lamp at 4 ft. (1.2 m).
- The radiation produced by a Miller Dial-Arc 250-P arcwelder at 10 ft. (3.0 m), set at 50 amps with 1/8 inch Type 601 welding rod.
- Vibration immunity for vertical displacement of 0.02 inches (0.5 mm) at a frequency of 10 to 30 Hz for 4 hours.
- Radio frequency interference (RFI) immunity at 12 inches to 155 MHz and 450 MHz with radiation power levels of 5.0 Watts.

Options

Model Q9001G Swivel Mounting Bracket.