

# Instructions

# 95-8353-05

Unitized Single Frequency  
Infrared Fire Detector/Controller  
U7698B

---



# Table of Contents

SYSTEM APPLICATION .....	1
FEATURES.....	1
DESCRIPTION .....	1
Flame Detection .....	1
Outputs.....	2
<b>oi</b> Feature .....	3
Detector Enclosure.....	3
SPECIFICATIONS .....	3
RESPONSE CHARACTERISTICS .....	5
GENERAL APPLICATION INFORMATION.....	5
INSTALLATION .....	5
Detector Positioning .....	5
Wiring Requirements.....	6
Wiring Procedure.....	6
STARTUP PROCEDURE .....	8
CHECKOUT PROCEDURE.....	9
MAINTENANCE.....	10
TROUBLESHOOTING.....	10
DEVICE REPAIR AND RETURN .....	11
ORDERING INFORMATION .....	11
Optional Equipment.....	11
Spare Parts .....	11

## List of Illustrations

Figure 1	Atmospheric Transmission of the Sun's Radiation .....	2
Figure 2	U7698B Block Diagram .....	2
Figure 3	Optical Integrity Feature .....	3
Figure 4	Cone of Vision .....	3
Figure 5	U7698B Dimensions in Inches (MM) .....	4
Figure 6	U7698B Detector/Controller Assembly.....	7
Figure 7	Cover Locking Clamp .....	7
Figure 8	Typical Wiring Diagram .....	8
Figure 9	Typical Multiple Unit Configuration .....	9

## List of Tables

Table 1	Typical Response Distances .....	5
---------	----------------------------------	---



## Unitized Single Frequency Infrared Fire Detector/Controller U7698B

### SYSTEM APPLICATION

The U7698B Unitized Single Frequency Infrared (IR) Fire Detector/Controller with manual Optical Integrity (**oi**) is a completely unitized fire detection device that incorporates all detection, signal processing, and switching components in a single enclosure. The U7698B provides reliable fire protection in areas that can present problems for other types of optical detectors. Typical applications for the U7698B include areas where:

- Harsh salt water conditions exist.
- Arc welding is common.
- A high concentration of ultraviolet attenuating vapors is present.
- Smoke can precede flames.
- Oil film or dust particles can accumulate on the detector viewing window.

The U7698B is ideally suited for:

- Oil rigs
- Refineries
- Transport loading facilities.

### FEATURES

- Detector and controller are housed in a single unit.
- Reduces the risk of false alarms caused by arc welding and lightning.
- Solar blind.
- Fire output relay is field programmable for latching or non-latching operation.
- LEDs provide visual indication of alarm condition.
- Manual **oi** feature provides convenient means of testing detector operation.
- Fault relay responds to problems such as a loss of input power.
- Operates under adverse weather conditions.

\***oi** is Detector Electronics' Trademark for its patented Optical Integrity Systems, U.S. Patent 3,952,196, United Kingdom Patent 1,534,969, Canada Patent 1,059,598.



- Choice of aluminum or stainless steel enclosure.
- Adjustable mounting bracket for ease of installation.
- Designed to meet Canadian Standards Association (CSA) and CENELEC explosion-proof requirements.

### DESCRIPTION

The U7698B Detector/Controller contains high quality electronic sensing and switching components in an explosion-proof enclosure. Through the use of optical filters and signal processing circuitry, the U7698B provides reliable response to the presence of a flame and is insensitive to signals from arc welding, lightning, and sunlight, making it suitable for a variety of indoor and outdoor applications.

### FLAME DETECTION

Every fire has characteristics or elements that distinguish it as a fire such as heat, smoke, visible light, ultraviolet (UV) and infrared (IR) radiation, and flame flicker.

These characteristics are important because fire is a chemical process, and chemical processes can vary significantly, depending on the elements and conditions. A simple fire detector can be designed to detect any one of these elements, but unless this detector is able to discriminate, it will be subject to false alarms. Discrimination can be achieved by using more than one element as criteria to detect a fire.

The U7698B detects two elements of fire: IR radiation and flame flicker. IR radiation is found throughout nature, but few things emit IR at the flicker frequency of a fire.

To ensure a high degree of reliability, precision optical filters limit IR response to a narrow band from 4.2 to 4.7 microns. This bandwidth is significant for two reasons:

1. Hydrocarbon fires emit intense IR radiation in this band.
2. Atmospheric transmission of IR from the sun in the 4.2 to 4.7 micron range is nearly zero. See Figure 1.

Refer to Figure 2 for a block diagram of the U7698B. Optical filters limit the radiation reaching the sensor to the range of 4.2 to 4.7 microns. The pyroelectric sensor converts the infrared energy to an electrical signal.

A flicker filter checks for flame flicker. Any signal that does not meet the flicker frequency requirements, such as steady state IR emissions, is rejected. The flicker rate is set at the factory for levels characteristic of a hydrocarbon fire (2 to 10 Hz). This flame criteria for the IR detector results in reliable response to the presence of fire combined with a high level of immunity from false alarms.

If the signal meets the requirements for a fire output (IR radiation of adequate amplitude, with proper wavelength and flicker frequency, and lasting for approximately 3 seconds), the signal processing circuitry triggers an output circuit, which energizes the alarm relay coil.

### OUTPUTS

The U7698B is furnished with two output relays. The relays have Form C (normally open/normally closed) contacts and are rated for 2 amperes at 30 vdc. The normally de-energized fire relay is energized upon detection of a fire that meets the previously described flame recognition criteria. It is also field programmable for either latching or non-latching operation. When latching operation is selected, the relay is reset by removing input power for a minimum of 2.0 seconds. The normally energized fault relay is de-energized upon loss of input power to the detector or if the sensor module is removed.

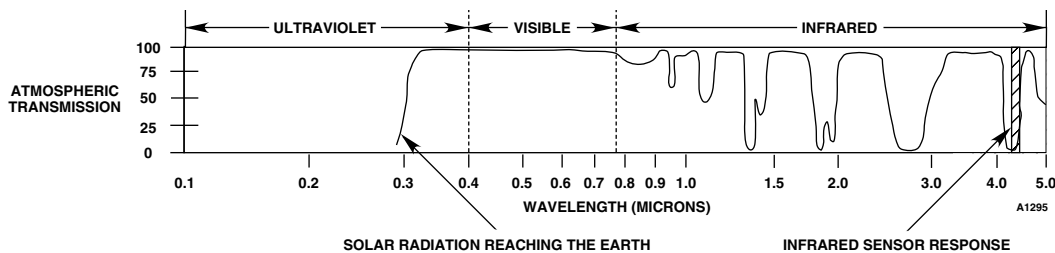

Figure 1—Atmospheric Transmission of the Sun's Radiation

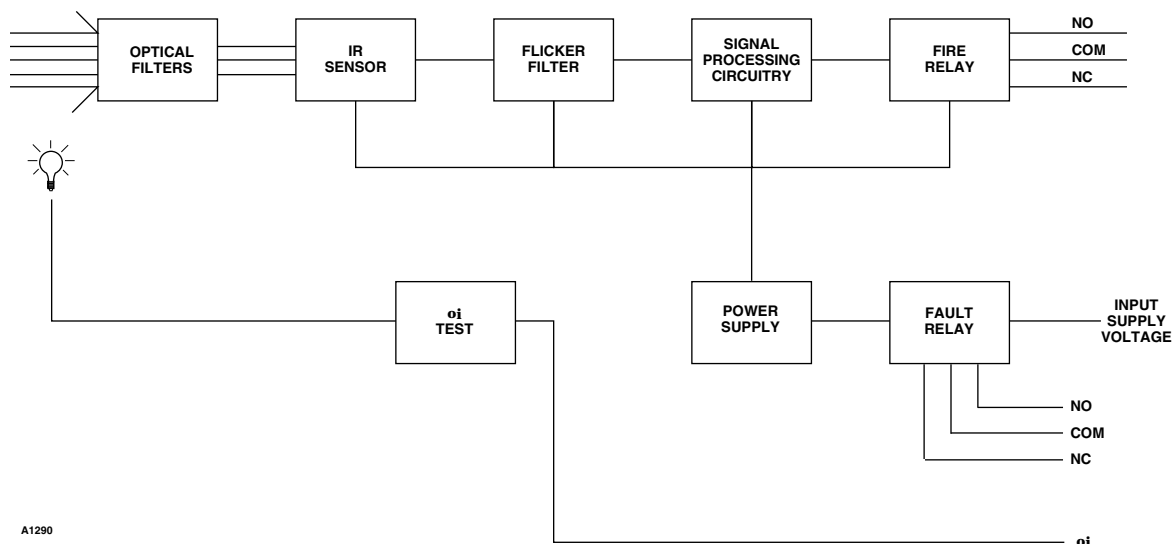

Figure 2—U7698B Block Diagram

Two LEDs are located inside the detector viewing window and are illuminated whenever the fire relay is energized.

### oi FEATURE

The U7698B is equipped with the Optical Integrity (**oi**) feature (manually initiated). This patented system assures proper operation of the detector by checking the cleanliness of the optical surfaces, sensitivity of the IR sensor, and proper functioning of the electronic circuitry. The **oi** test is accomplished without the use of an external IR source. It can be performed at any time by the operator in the control room by simply pressing a button. (Fire response equipment must be disabled during the **oi** test to prevent actuation.) The normally open switch used to activate the manual **oi** test must be connected between the “**oi**” terminal and the “-” of the power supply. The “**oi**” terminal must be at less than 0.1 volt to activate the **oi** test.

The **oi** system generates a low level flickering IR test beam using two small IR test lamps that are located inside the detector enclosure. An optical shield prevents this test beam from reaching the sensor directly. Instead, the test beam travels through the viewing window where it strikes a reflective **oi** ring and is directed back through the window and into the sensor. See Figure 3. The sensor then generates an electrical signal that is processed by the circuitry in the controller. A successful **oi** test results in activation of the alarm relay and illumination of the red LEDs inside the detector viewing window. If the detector optics are dirty or an IR module problem has caused a decrease in sensitivity to the point where approximately 50% of the detection range is lost, the detector will fail the **oi** test. Since the **oi** test beam must pass through the same portion of the viewing window as IR radiation generated by a fire, the **oi** system provides a reliable test of the ability of the detector to “see” a fire. The fault relay is unaffected by the **oi** test.

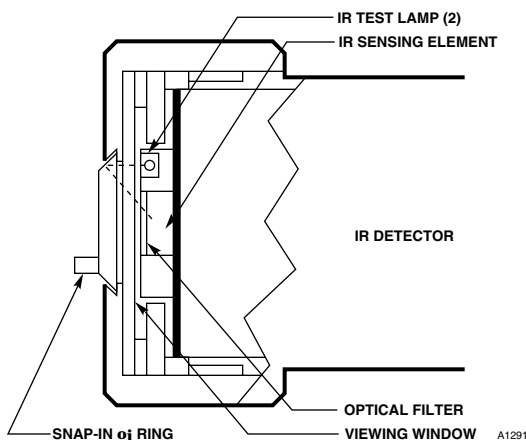

Figure 3—Optical Integrity Feature

### DETECTOR ENCLOSURE

The U7698B features an explosion-proof housing that is designed for installation in hazardous locations in both indoor and outdoor environments. The detector is not affected by adverse weather conditions such as wind, rain, snow, high humidity, or extremes of temperature or pressure.

### SPECIFICATIONS

#### OPERATING VOLTAGE—

24 vdc nominal, 18 to 32 vdc maximum.

#### POWER CONSUMPTION—

1.0 watt nominal, 3.5 watts maximum during **oi** test.

#### POWER ON DELAY—

8 seconds. The fault relay will energize in less than 1 second.

#### OUTPUT RELAYS—

The U7698B has two Form C (N.O. and N.C.) relays. The normally de-energized alarm relay is programmable for either latching or non-latching operation. The normally energized fault relay is de-energized in the event of a power failure or removal of the IR module.

#### RESET TIME—

Reset requires 0 volts at the detector for 2.0 seconds (when latching operation is selected).

#### RELAY CONTACT RATING—

Form C, rated 2 amperes at 30 vdc.

#### SPECTRAL SENSITIVITY RANGE—

4.2 to 4.7 microns.

#### CONE OF VISION—

80 degree cone of vision. See Figure 4.

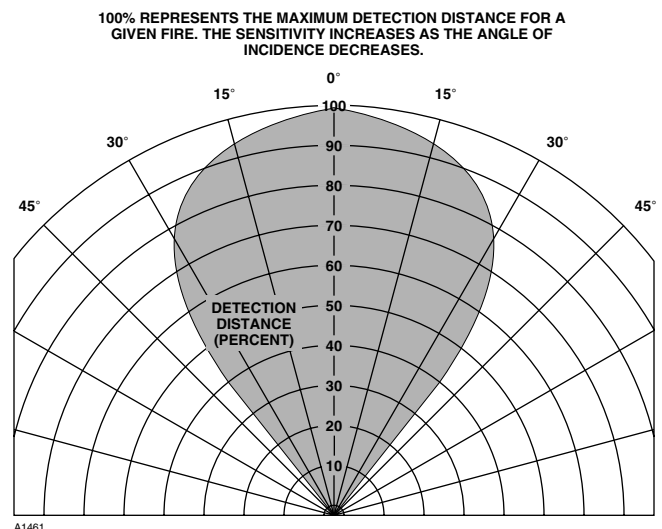

Figure 4—Cone of Vision

**FLAME SENSITIVITY—**

The U7698B detects a 1 foot by 1 foot gasoline fire at 65 feet, a 1 foot by 1 foot diesel fire at 60 feet, a 1 foot by 1 foot methanol fire at 50 feet.

**RESPONSE TIME—**

The response time of the detector is a function of fuel, fire size, distance, and orientation of the fire source. Typically, the U7698 will respond in 3 seconds to a high intensity flickering IR source and within 8 to 10 seconds to a 1 square foot gasoline fire at 65 feet (approximately 0.1 square meter at 20 meters).

**TEMPERATURE RANGE—**

Operating: -40°F to +167°F (-40°C to +75°C).  
Storage: -40°F to +185°F (-40°C to +85°C).

**HUMIDITY RANGE—**

0 to 95%, can withstand 100% condensing humidity for short periods of time.

**ENCLOSURE MATERIALS—**

Anodized aluminum or 316 stainless steel, with stainless steel mounting brackets.

**CERTIFICATION—**

VDS: Performance verified to EN 54-10.

CSA: Class I, Division 1, Groups C and D;  
Class II, Division 1, Groups E, F, and G;  
NEMA 4.

CENELEC: DEMKO 03 ATEX 135331X  
⊗ II 2 G EEx d IIC T4-T6  
T6 (Tamb -55°C to +60°C)  
T5 (Tamb -55°C to +75°C)  
T4 (Tamb -55°C to +125°C)  
⊗ II 2 D T130°C.  
IP66.

Special Conditions for Safe Use:

- The Model U7698A/B/C Flame Detectors have an ambient temperature rating for performance of -40°C to +75°C.
- The maximum surface temperature designation T 130°C is based on the maximum ambient temperature of 75°C and under dust layers with up to 5mm thickness.
- Precautions must be taken to ensure that the electronics will not operate at ambient temperatures exceeding 110°C.
- For use in Dust environments the Models U7698A/B/C Flame Detectors are to be used only in Zone 21 (Category 2) or Zone 22 (Category 3) applications.

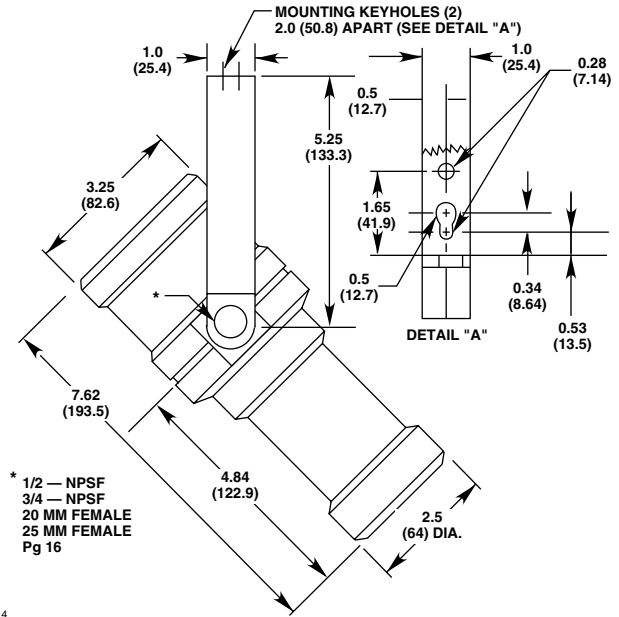

Figure 5—U7698B Dimensions in Inches (Millimeters)

**DIMENSIONS—**

See Figure 5.

**WIRING—**

16 to 22 AWG. Shielded cable is recommended to provide increased immunity to RFI and EMI. A conduit entry adapter is located on one side of the detector/controller and a stop plug is located on the other. A second conduit entry adapter can be added by replacing the stop plug with an adapter. See Figure 5 for thread sizes.

The adapter and plug are also used to tighten the detector/controller to the mounting bracket in a fixed position.

**VIBRATION—**

The U7698B meets MIL-STD-810C for vibration.

**SHIPPING WEIGHT (Approximate)—**

	<b>Pounds</b>	<b>Kilograms</b>
Aluminum	4.0	1.8
Stainless steel	8.1	3.7

Table 1—Typical Response Distances

Flammables	Distance From Detector
Acetone	60 feet (18 meters)
Diesel	60 feet (18 meters)
Gasoline	65 feet (20 meters)
Methanol	50 feet (15 meters)
Toluene	50 feet (15 meters)
Fine wood shavings (excelsior)	50 feet (15 meters)
Methane	35 feet (10 meters)

## RESPONSE CHARACTERISTICS

Response is dependent on the fuel, the temperature of the fuel, and the time required for the fire to build. As with all fire tests, results must be interpreted according to the individual application.

Typical response distances of the U7698 to various flammable materials are listed in Table 1. Fuel for the fire is approximately one pint of liquid or one pound of wood shavings and is burned in a 1 foot by 1 foot steel pan. Methane gas fire is performed with the flame approximately 30 inches high and 6 to 8 inches in diameter. The U7698 was sited to observe the fire at center axis  $\pm$  10 degrees.

Typically, the U7698 will respond in 3 seconds to a high intensity flickering IR source and within 8 to 10 seconds to a 1 square foot gasoline fire at 65 feet (approximately 0.1 square meter at 20 meters).

## GENERAL APPLICATION INFORMATION

The U7698B provides reliable response to the infrared radiation emitted from hydrocarbon fires while remaining insensitive to solar radiation and artificial lighting. However, to achieve maximum performance of the fire protection system, it is necessary to recognize any conditions that can prevent the unit from responding to fire as well as any sources besides fire that can cause the detector to respond.

Any object with a temperature greater than 0° Kelvin (-273°C) emits infrared radiation. The hotter the object, the greater the intensity emitted between 4.2 and 4.7 microns. The U7698B ignores steady state infrared sources that do not have a flicker frequency characteristic of a fire. However, it should be noted that if these steady state infrared sources are hot enough to emit adequate amounts of infrared radiation in the 4.2 to 4.7 micron range and if this radiation becomes interrupted from the view of the detector in a pattern characteristic of a flickering flame, the unit can respond and go into alarm. The closer the infrared source is to the detector, the greater the potential for a false alarm.

Arc welding should not be performed within 10 feet of the detector. Although only a low level of radiation in the 4.2 to 4.7 micron range is emitted by the welding, the heated metal can become a false alarm source.

The U7698B is resistant to interference by EMI and RFI. It will not respond to a 5 watt walkie-talkie at a distance of greater than 1 foot.

The U7698B is a single frequency infrared device with detection limited to the hot CO<sub>2</sub> emission peak, therefore, it cannot be used to detect fires that do not contain carbon, such as hydrogen, sulfur, and burning metals.

## INSTALLATION

### DETECTOR POSITIONING

The U7698B has an 80 degree cone of vision that covers a somewhat elliptical area when it is angled to cover the hazardous area. It is important to note that as the distance increases between the detector and the fire source, so does the response time of the detector to a fire of a given size. For fastest response time, locate the detector as close as possible to the anticipated fire source. Be sure that enough detectors are used to adequately cover the hazardous area. For outdoor applications, the detector should be aimed downward to prevent it from scanning the horizon. This minimizes the response to distant infrared sources outside the protected area.

Although the infrared detector is less affected by smoke than other detectors, the U7698B should not be placed where rising CO<sub>2</sub> and particulates can obscure its vision. For indoor applications, if dense smoke is expected to accumulate at the onset of a fire, mounting the detector on a side wall a few feet (1 meter) down from the ceiling will normally allow enough time for the unit to respond before it is affected by rising smoke. If possible, fire tests should be conducted to determine correct detector positioning and coverage.

## WIRING REQUIREMENTS

The system should be wired using a 16 to 22 gauge (1.5 to 0.5 mm<sup>2</sup>) cable. The use of shielded cable is highly recommended to protect against interference caused by extraneous electrical “noise.” In applications where the wiring cable is installed in conduit, the conduit should not be used for wiring to other electrical equipment. Foil type shielded cable is recommended to protect from electromagnetic and radio frequency interference. The size and length of cable should be considered when wiring the system to ensure that a minimum input voltage of 18 vdc is present at the U7698B. When using cables with shields, the shield should be cut back and insulated at each unit.

### NOTE

*It is important to use cable that is suitable for the installation environment. In applications involving high humidity or salt water, use a cable that is made specifically for harsh, salt water environments. In all cases, typical cable insulation resistance should be at least 100 megohms. If the resistance drops below 10 megohms, the cable could be deteriorating and should be replaced to avoid shorting out the system. When testing the insulation resistance, disconnect the leads from the detector/controller before connecting the megohmmeter (insulation tester) to the cable.*

Since moisture can be detrimental to electronic devices, it is important that moisture not be allowed to come in contact with the electrical connections of the system. Moisture in the air can become trapped within sections of conduit, therefore the use of conduit seals is required to prevent damage to electrical connections caused by condensation within the conduit. These seals must be water-tight and explosion-proof and are to be installed even if they are not required by local wiring codes. A seal must be located as close to the U7698B as possible. In no case should this seal be located more than 18 inches (46 cm) from the unit. When an explosion-proof installation is required, an additional seal must also be installed at any point where the conduit enters a non-hazardous area.

When pouring a seal, the use of a fiberdam is required to assure proper formation of the seal. The seals should

never be poured in temperatures that are below freezing, since the water in the sealing compound will freeze and the compound will not dry properly. Contamination problems can then result when temperatures rise above the freezing point and the compound thaws. The shielding of the cable should be stripped back to permit the seal to form around the individual leads, rather than around the outside of the shield. This will prevent any siphoning action that might occur through the inside of the shield.

Moisture in the air can be trapped within sections of conduit and can condense and accumulate at the base of vertical conduit runs. To eliminate this condition, explosion-proof drains and breathers should be installed to automatically bleed off accumulated water.

When using steel wire armored or mineral-insulated copper-sheathed cables, select an approved gland with a watertight compression stage and an overall gland shroud for outdoor applications. A sealing washer must be fitted between the gland and the conduit entry to ensure IP66 rating.

## WIRING PROCEDURE

The following procedure should be used for mounting and wiring the U7698B.

1. The detectors should be positioned to provide the best unobstructed view of the area to be protected. Be sure that the units are easily accessible for cleaning and other periodic servicing. Particular attention should also be paid to potential false alarm sources within the cone of vision of the detector, such as the rotating blades of a fan or surface vibration of an IR source, since these could allow a flickering IR signal to reach the detector. Dense fog, rain, or ice can absorb IR radiation, which can reduce the capability of the detector. For outdoor applications, aim the detector downward to prevent the cone of vision from scanning the horizon. This minimizes response to distant IR sources outside the protected area.

### NOTE

*The wiring procedures in this manual are intended to ensure proper functioning of the device under normal conditions. However, because of the many variations in wiring codes and regulations, total compliance to these ordinances cannot be guaranteed. Be certain that all wiring complies with applicable regulations that relate to the installation of electrical equipment in a hazardous area. If in doubt, consult a qualified official before wiring the system.*

2. Mount the bulkhead and mounting bracket assembly of the detector/controller on the wall or ceiling. See Figure 6. The mounting surface must be free of



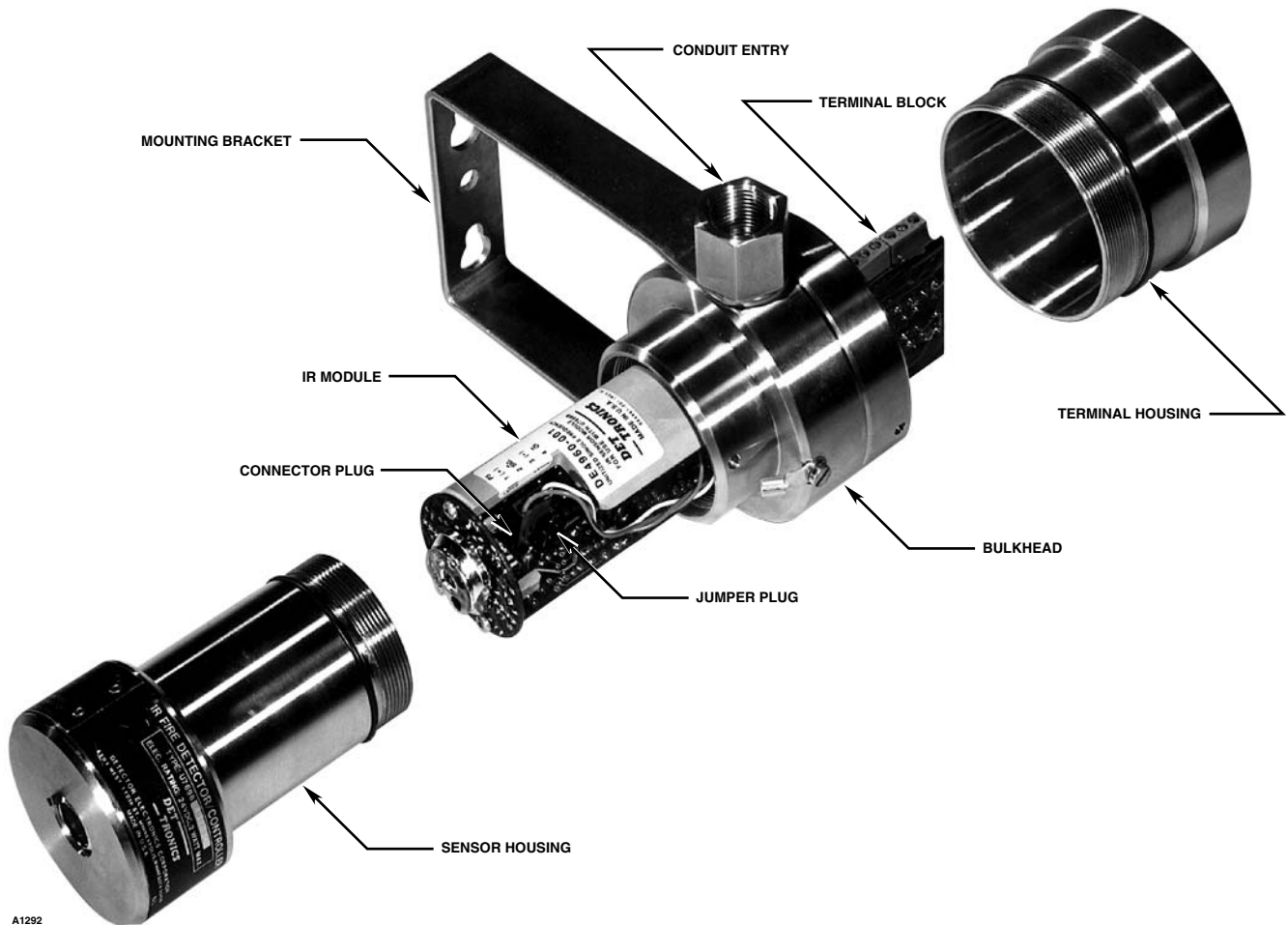

A1292

Figure 6—U7698B Detector/Controller Assembly

vibration and suitable to receive 1/4 inch (M6) screws with a length of at least 1 inch (25 mm).

3. If the unit is equipped with a cover locking clamp, loosen it with a 5/32 hexagonal (Allen) wrench and move the clamp “catches” out of the blind holes located in the bulkhead. See Figure 7.

**CAUTION**

*Never open the detector enclosure while power is applied.*

4. Remove the terminal housing and sensor housing from the bulkhead by turning them counterclockwise.

**CAUTION**

*The U7698B contains semiconductor devices that are susceptible to damage by electrostatic discharge. An electrostatic charge can build up on the skin and discharge when an object is touched. Therefore, use caution when handling, taking care not to touch the terminals or electronic components. For more information on proper handling, refer to Service Memo form 75-1005.*

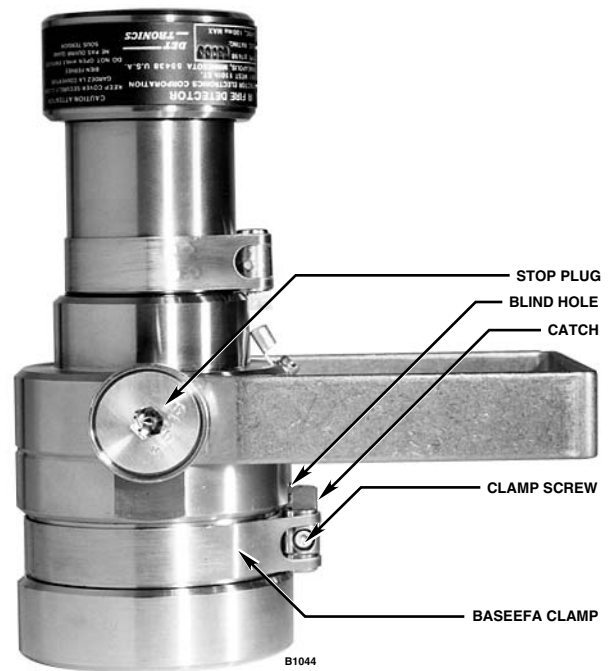

B1044

Figure 7—Cover Locking Clamp

5. Route the field wiring through the detector conduit entry.
6. Attach the wires to the appropriate screw terminals on the terminal block. Refer to Figure 8 for wiring a single unit and Figure 9 for a multiple configuration. Connect the shield to earth ground at the power source. Do not ground the shield at the detector/controller housing (unless required by local codes).
7. To wire the **oi** test switches, connect a normally open switch between the negative (-) side of the dc power source and the terminal marked "oi" on the detector terminal block. Each detector must have its own **oi** test switch.
8. Check all field wiring to be sure that the proper connections have been made. If conduit is used, pour the conduit seals and allow them to dry.
9. Remove the IR module from its shipping package.
10. The alarm relay is factory programmed for latching operation. To program the relay for non-latching operation, a jumper plug that is located on the IR module must be re-positioned. See Figure 6 to locate the jumper plug. Refer to the label on the side of the IR module to determine the correct position for the jumper plug.
11. Thread the wire leads and keyed connector plug through the slotted opening on the IR module. Plug the IR module into the two banana plugs in the bulkhead.

**NOTE**

The two **oi** lamps should be at the **top** of the detector (when viewed from the front) and the opening on the **oi** ring should be directly opposite the test lamps. This will ensure proper operation of the **oi** system and also minimize the accumulation of moisture and contaminants between the **oi** ring and the viewing window.

12. Connect the keyed connector plug to the 4-pin connector on the IR module.
13. Replace the terminal housing and the sensor housing. The O-rings must be properly seated to ensure the water-tight and explosion proof integrity of the housing. If the unit is equipped with cover locking clamps, loosen the clamps sufficiently so that the clamp catches can be seated in the blind holes on the bulkhead. Fasten the clamps securely using a 5/32 inch hexagonal (Allen) wrench. (See Figure 7.)
14. For best **oi** performance, the opening on the **oi** ring should be positioned directly opposite the two **oi** test lamps. In addition, the opening should be pointed down to minimize the accumulation of moisture or contaminants behind the ring.

**STARTUP PROCEDURE**

When the installation of the equipment is complete, the following startup procedure should be performed.

1. Disable any extinguishing equipment that is connected to the system.
2. Apply input power to the system. Allow an 8 second power-on delay.

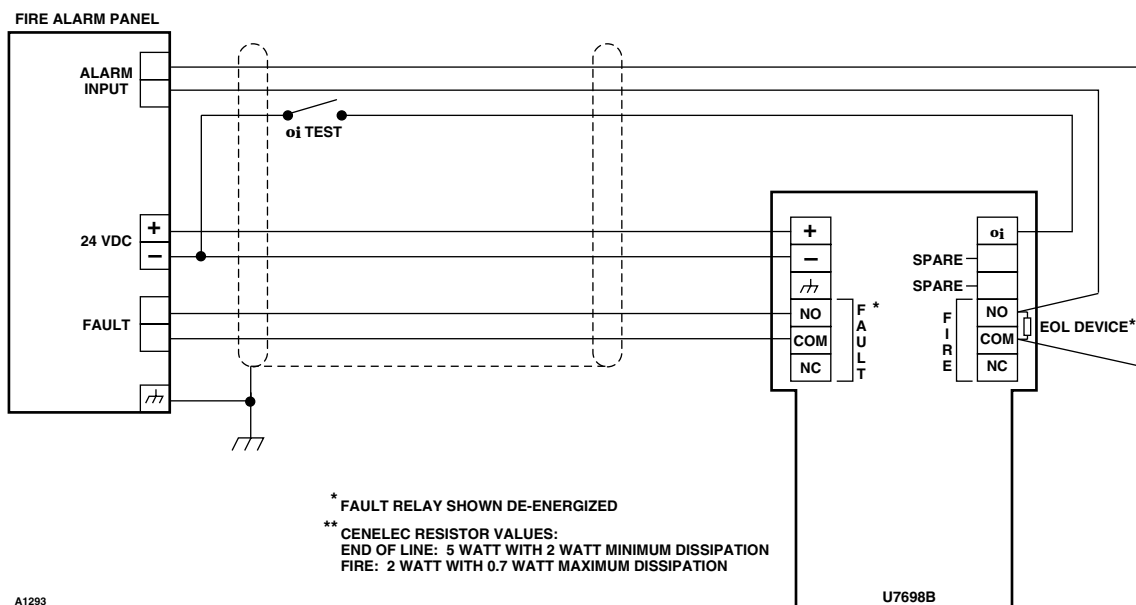

Figure 8—Typical Wiring Diagram

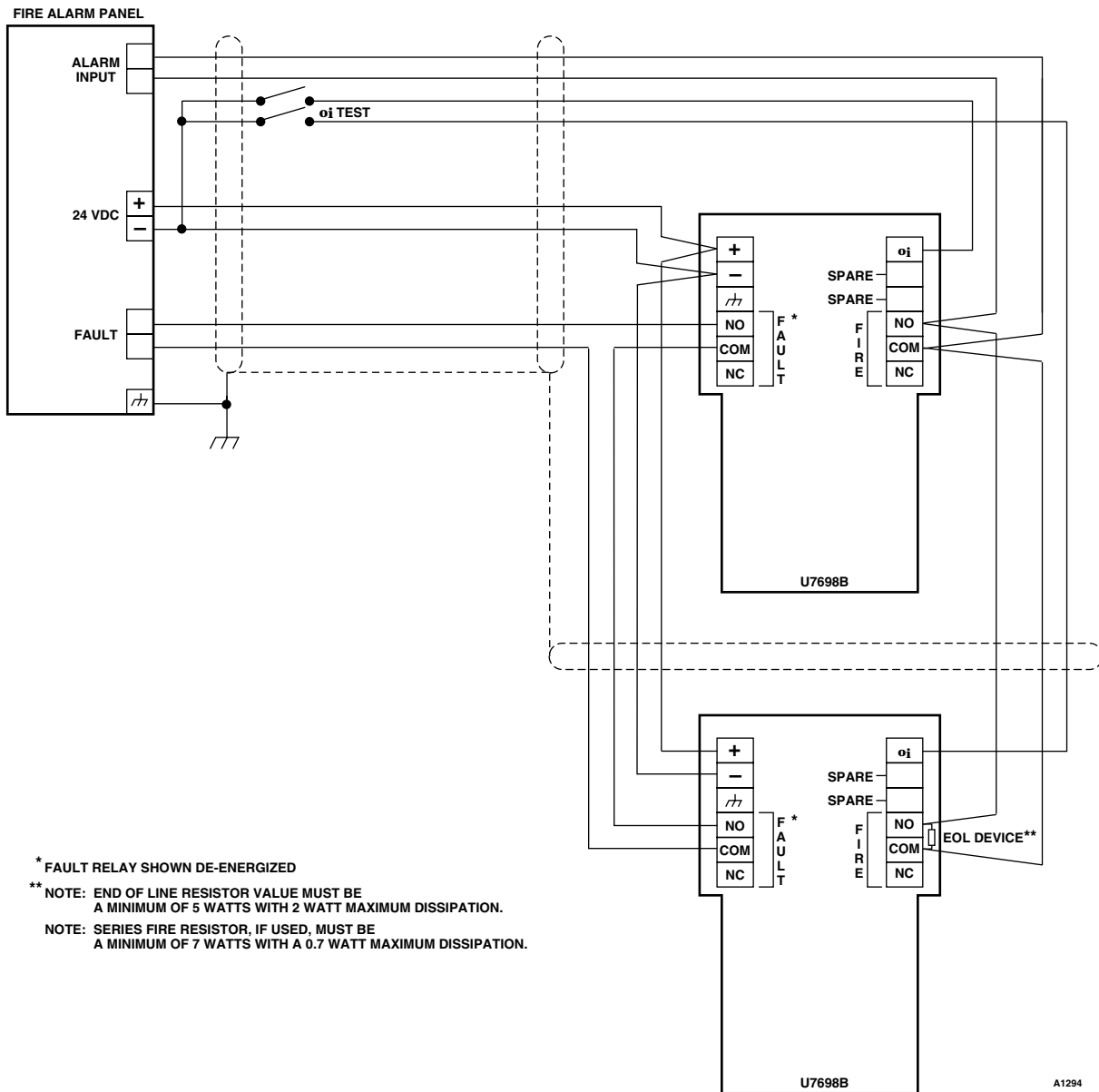

Figure 9—Typical Multiple Unit Configuration

3. Hold a flickering IR source (such as the Det-Tronics model W867 Test Lamp) close to the detector or press the **oi** test button for 5 to 10 seconds. The alarm relay will energize and the LEDs will be illuminated when the device goes into an alarm condition.
4. Remove the IR source (or release the **oi** test button). If the unit is programmed for non-latching operation, the alarm relay will become de-energized and the LEDs will turn off when the IR source is removed. If the unit is programmed for latching operation, it can be reset by removing input power (2.0 seconds minimum).
5. Repeat this test for all detector/controllers in the system. If a unit fails the test, refer to the "Troubleshooting" section of this manual.
6. Double check all detectors in the system to be sure that they are properly aimed at the potential hazard.
7. Turn on all extinguishing equipment that is connected to the system.

## CHECKOUT PROCEDURE

A checkout of the system using the **oi** feature, a flame, or other flickering IR source should be performed on a regularly scheduled basis to ensure that the system is operating properly. The period between checkouts will depend on the level of potential hazard involved and the environmental conditions encountered. In general, the more frequent the checkouts, the greater the reliability of the system.

### **CAUTION**

*Any extinguishing equipment connected to the system must be disabled when the system is tested to prevent unwanted actuation of this equipment.*

To test the system, point a flickering IR source at each unit or activate the **oi** test for five to ten seconds. Alarm response indicates that the viewing window is clean and that all electronic circuitry is operational. Lack of response may indicate reduced sensitivity due to contamination on the viewing window, a damaged sensor, or electronic circuitry problems. Refer to the "Troubleshooting" section of this manual if the detector does not respond properly.

### **MAINTENANCE**

The detector requires no periodic calibration. However, to maintain maximum sensitivity, the viewing window must be kept clean at all times. The length of time between periodic cleanings will be determined by the nature and amount of contaminants present in the environment.

Remove the **oi** ring from the detector and clean the viewing window thoroughly, all the way to the edge. Also clean the back side of the **oi** ring. When re-installing the reflective **oi** ring, hold it by its tabs to avoid leaving fingerprints on the reflective surface. Re-install the ring so that the opening is positioned directly opposite the **oi** test lamps on the detector. The opening should be pointed down to prevent a buildup of contaminants. If corrosive contaminants in the atmosphere cause the reflective rings to deteriorate to the extent that it is no longer possible to restore them to their original condition, they must be replaced.

To clean the window use a clean cloth or tissue and Det-Tronics window cleaning solution (part number 001680-001).

### **NOTE**

*Remove input power when cleaning the detector windows to prevent unwanted output activation.*

Rubber O-rings are used to ensure the watertight integrity of the detector housing. Periodically, the housings should be opened and the O-rings inspected for breaks, cracks, or dryness. To test the O-rings, remove them from the detector housing and stretch them slightly. If cracks are visible, they should be replaced. If they feel dry to the touch, a thin coating of lubricant should be applied. When re-installing the O-rings, be sure that they are properly seated in the groove on the housing. It is imperative that these O-rings be properly installed and in good condition. Failure to properly maintain the O-rings can allow water to enter the detector and cause premature failure. The life expectancy of rubber O-rings

can vary considerably, depending on the amount and nature of contaminants that are present in the environment.

A coating of lubricant should also be applied to the threads on the detector enclosure before re-assembling the detector. This will both lubricate the threads and help to prevent moisture from entering the detector housing.

### **TROUBLESHOOTING**

Before disassembling the unit, perform the following steps.

1. Disable any extinguishing equipment that is connected to the unit.
2. Inspect the viewing window for contamination. The infrared detector is relatively insensitive to airborne contaminants, however, thick deposits of ice, dirt, or oil will reduce sensitivity. To clean the window, use Det-Tronics window cleaner (part number 001680-001) and a soft cloth or tissue. (Refer to the "Maintenance" section of this manual for complete information regarding cleaning of the detector viewing window.)
3. Check input power to the unit.
4. Hold a flickering IR source close to the detector or press the **oi** test button for five to ten seconds. The alarm relay will energize and the LEDs will turn on.
5. Remove the IR source (or release the **oi** test button). The alarm relay will become de-energized and the LEDs will turn off if non-latching operation is selected.
6. If the device did not respond properly, check the **oi** lamps to be sure that they flash during the **oi** test and also check the **oi** ring for proper alignment. Turn off the input power to the system and check all wiring for continuity.
7. If the wiring checks out, replace the IR module.
  - a. Remove the sensor housing (see Figure 6).

### **CAUTION**

*Do not open the detector/controller housing in a hazardous area without first removing power, including power to the relay contacts.*

- b. Remove the connector plug from the IR module.
- c. Unplug the IR module from the bulkhead.

- d. Check the jumper plug on the replacement IR module for proper position, then install the module in the bulkhead (with the oi test lamps positioned at the top of the detector). Attach the connector plug.
- e. Ensure that the O-rings at the base of the sensor housing are positioned correctly and in good condition. (Refer to the "Maintenance" section of this manual for complete information regarding care of O-rings.)
- f. Replace the sensor housing and check the position of the oi ring.
- g. Perform the "Startup Procedure" as described in this manual before returning the system to normal operation.

## DEVICE REPAIR AND RETURN

The U7698B Detector/Controller is not designed to be repaired in the field. If it is determined that the unit is defective, it must be returned to the factory for repair.

Prior to returning devices or components, contact the nearest local Detector Electronics office so that an RMI (Return Material Identification) number can be assigned. A written statement describing the malfunction must accompany the returned device or component to expedite finding the cause of the failure, thereby reducing the time and cost of the repair to the customer.

Pack the unit or component properly. Use sufficient packing material in addition to an antistatic bag or aluminum-backed cardboard as protection from electrostatic discharge.

Return all equipment transportation prepaid to the factory in Minneapolis.

## ORDERING INFORMATION

When ordering, specify model and options.

U7698B Unitized IR Detector/Controller with manual **oi**

Enclosure material:

- Anodized copper-free aluminum
- 316 Stainless steel.

Conduit entries:

- 1/2-14 NPT
- 3/4-14 NPT
- M20 x 1.5 - 6H
- M25 x 1.5 - 6H

## OPTIONAL EQUIPMENT

**Voltage converters** are available from Detector Electronics for operating the system from line (mains) voltage.

**Air Shield** allows the detector to be used in "dirty" environments and extends detector maintenance intervals by reducing the accumulation of airborne contaminants on the detector viewing window.

**W867 Test Lamp** provides a flickering IR signal for on-site testing of the detector.

## SPARE PARTS

Electronic Module	004960-xxx
Window cleaner squeeze bottle (package of six bottles)	001680-001
Stainless steel snap-in <b>oi</b> ring	002519-001
Small O-ring (two required per unit)	107427-004
Large O-ring (two required per unit)	107427-007
Conduit entry O-ring	107427-006

For assistance in ordering a system to fit your application, please contact:

Detector Electronics Corporation  
 6901 West 110th Street  
 Minneapolis, Minnesota 55438 USA  
 Operator: (952) 941-5665 or (800) 765-FIRE  
 Customer Service: (952) 946-6491  
 Fax: (952) 829-8750  
 Web site: [www.detronics.com](http://www.detronics.com)  
 E-mail: [detronics@detronics.com](mailto:detronics@detronics.com)



Printed in USA

Detector Electronics Corporation  
6901 West 110th Street • Minneapolis, Minnesota 55438 USA  
Tel: 952.941.5665 or 800.765.3473 • Fax: 952.829.8750