AUTOMATIC **oi***

UV/IR Flame Detection System
R7495B Controller
C7052J Detector
NOTE

Not compliant to FM 3260 (2000).

APPLICATION

The R7495B/C7052J UV/IR Flame Detection System is designed to provide continuous and automated fire protection in applications where the use of ultraviolet (UV) or infrared (IR) detectors alone can result in unwanted (false) alarms. The R7495B/C7052J system features a flame detector that uses both a UV and a single frequency IR sensing device mounted side-by-side on a junction box assembly.

When used alone, a UV detector can respond to sources of radiation besides fire, such as lightning, x-rays or arc welding. A UV detector does not respond to the radiation emitted by flickering hot objects. Likewise, an IR detector can respond to infrared radiation sources besides hydrocarbon fires, such as flickering hot objects. An IR detector does not respond to radiation from lightning, x-rays or arc welding. Since both UV and IR sensors respond to hydrocarbon fires but have virtually no false alarm sources in common, the R7495B/C7052J UV/IR system provides reliable flame detection while being virtually immune to false alarms.

The detector junction box contains a power supply and signal processing circuitry for the sensors. A fire signal is generated in the detector junction box and sent to the controller only when a fire is simultaneously detected by both the UV and IR sensors. Since the two detecting elements independently monitor different portions of the radiation spectrum and have virtually no sources of output actuation in common besides fire, a high degree of false alarm immunity is achieved. The controller contin-

***oi** is Detector Electronics' Trademark for its patented Optical Integrity Systems, U.S. Patent 3,952,196, United Kingdom Patent 1,534,969, Canada Patent 1,059,598.



uously monitors up to eight UV/IR detectors and energizes the appropriate relay outputs in response to a fire signal from the detectors. Fire relays are provided in the controller: two instant (alarm) relays, two delayed (fire) relays, and a system fault relay.

Typical applications include:

- Transport loading terminals
- Offshore drilling and production platforms
- Tank farms
- Refineries
- Butane and propane loading and storage
- Pipeline compressor stations
- Turbine enclosures
- Aircraft Hangars
- Paint Spray Booths
- Chemical and petrochemical production

FEATURES

- Controller continuously monitors up to eight detectors.
- Detectors can be divided into either two groups of up to four detectors, each with its own alarm and fire zone output, or one group of up to eight detectors with two alarm and two fire zone outputs.
- Two fire zone relays, two alarm relays and a fault relay provided.
- Ignores false alarm sources such as arc welding, x-rays, gamma radiation and radiation from flickering hot objects.
- Fast response - typically 1 to 5 seconds for an intense hydrocarbon fire.
- Field adjustable sensitivity and time delay.
- Front panel LEDs indicate fire response and fault conditions.
- Microprocessor control provides continuous diagnostics and automatic fault indication.
- Automatic Optical Integrity (**oi**) for both UV and IR sensors.
- Explosion-proof (flame-proof) detector housing
- FM approved, CSA and BASEEFA/CENELEC certified.
- Voting circuitry for improved false alarm rejection.

SYSTEM DESCRIPTION

Detector

The C7052J UV/IR Flame Detector is an explosion-proof device that consists of a UV sensor and an IR sensor mounted side-by-side on a junction box. This mounting arrangement allows both sensors to monitor the same hazardous location with a 80 degree cone of vision. Up to eight C7052J Detectors can be connected to one R7495B Controller.

The UV sensor responds to high energy radiation with wavelengths from .185 to .245 microns (1850 to 2450 angstroms). See Figure 1. It detects radiation from sources such as fire, arc welding, lightning, x-rays and

gamma rays. However, it is not sensitive to radiation from the sun or radiation from flickering hot objects (blackbodies).

The IR sensor is sensitive to IR radiation over the range of 4.2 to 4.7 microns. See Figure 1. It is not sensitive to radiation from the sun, lightning, x-rays, gamma rays, or arc welding. However, it will respond to fire and flickering blackbody (heat) radiation sources. IR radiation that is generated by a hydrocarbon flame which reaches the detector in pulsations or "flicker." These pulsations are present in all flames and are created by turbulent mixing of fuel with air. For this reason, electronic circuitry in the detector monitors the output of the IR sensing element for the appropriate amplitude and a flicker frequency between 1 and 16 cycles per second. If both the radiation and flicker requirements are met, a fire signal is generated. This dual criteria for the IR detector results in increased reliability. However, since the IR detector responds only to hydrocarbon fires, the UV/IR detector cannot respond to non-hydrocarbon fires such as burning hydrogen, ammonia or metal.

The detector junction box contains a +290 vdc power supply for the UV sensor as well as circuitry to process signals from both sensors. When both sensors detect a fire, the IR sensor activates the circuitry in the junction box to allow the signal from the UV sensor to be sent to the controller. By using both a UV and an IR sensor, the C7052J is able to discriminate virtually all false alarm sources from a true hydrocarbon fire.

oi Feature

Both sensors are equipped with the automatic Optical Integrity (**oi**) test feature. This patented system assures proper operation of the detector by checking the cleanliness of the optical surfaces, sensitivity of the sensors, and proper functioning of the electronic components of the detector once every minute. If a problem should occur, it is quickly detected. The **oi** test is accomplished without the use of an external UV or IR source. To minimize the possibility of nuisance fault signals, the detector must fail the automatic **oi** test three consecutive times for an **oi** fault signal to be generated.

The **oi** test is initiated by a signal from the controller which causes actuation of the **oi** test lamps. A calibrated low level test beam is generated by the **oi** test

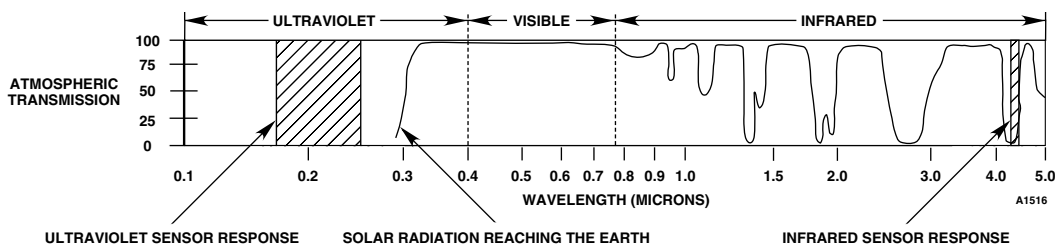

Figure 1—Detector Sensitivity Range

lamps, as shown in Figure 2. Although the test lamps are mounted in the same enclosure with the sensor, an optical shield prevents the test beam from reaching the sensor directly. The test beam travels out through the viewing window, where it encounters the reflective **oi** ring and is directed back through the window to the sensor. Electronic circuitry in the detector then evaluates the return signal from the sensor and generates the appropriate output response. Since the test beam must pass through the same portion of the viewing window as radiation produced by a fire, this test of the ability of the detector to “see” a flame has a high degree of reliability.

Detector Enclosure

The C7052J features an explosion-proof, dust-tight, and water-tight (NEMA 4/IP66) housing that is designed for installation in hazardous locations in both indoor and outdoor environments. The enclosure is FM approved, CSA certified, and BASEEFA/CENELEC approved.

Controller

The R7495B is designed for use with 24 volt dc power supplies, but will operate from any direct current supply between 18 and 32 volts. The unit will tolerate transients such as those that can occur when fully discharged batteries are placed on charge. When power is present at the R7495B Controller, it is indicated by a continuously energized green LED. All other lights and displays on the R7495B front panel are normally off, but may be periodically checked for operation by pressing the RESET/LAMP TEST button located directly below the POWER light as illustrated in Figure 3. It is not necessary for the controller to be in the TEST mode when this check is performed.

With power applied and the TEST/NORM toggle switch in the normal mode, the R7495B Controller continuously cycles through the Automatic Optical Integrity test (see the “**oi** Feature” section), checking each detector and its wiring. At the same time, it monitors the system for any status changes, such as a fault, a “fire” signal from one of the detectors or zones, or a change in the setting of the TEST/NORM toggle switch. If a status change occurs, the controller will respond accordingly by indicating the change on the front panel LEDs and generating the appropriate output.

Front Panel

The front panel of the R7495B provides switches for selecting mode of operation and resetting the controller. It also provides LEDs for indicating system status information. Figure 3 illustrates the front panel of the controller.

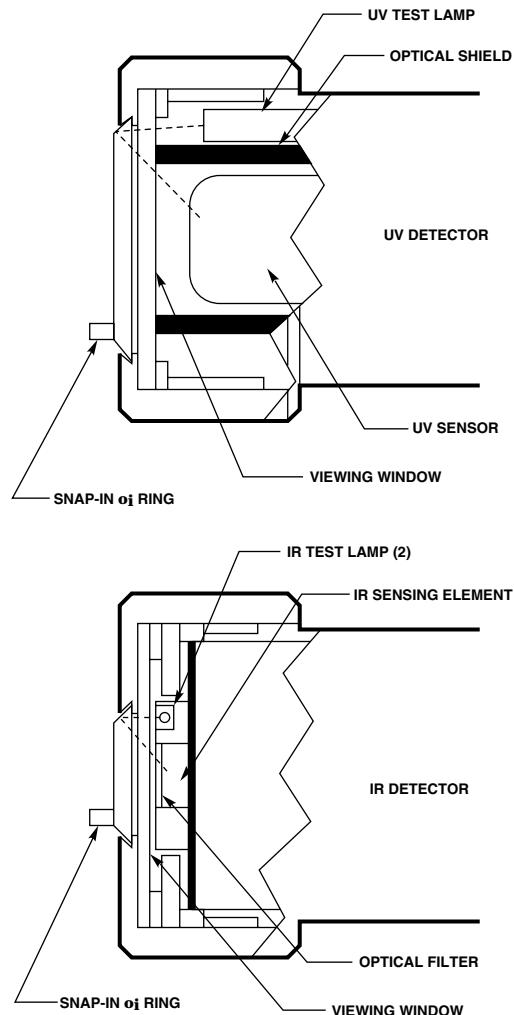

Figure 2—**oi** Function within the Detector

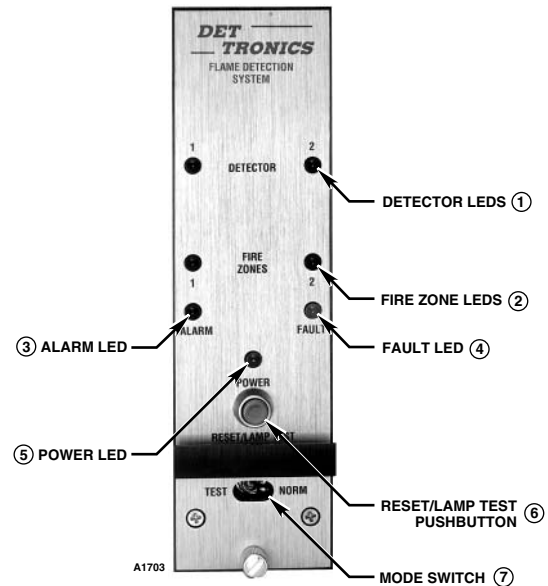

Figure 3—R7495B Controller Front Panel

1. A DETECTOR LED for each channel provides an immediate visual indication that a fire has been detected. The LED blinks slowly (once per second) if the fire intensity does not exceed the fire threshold and blinks rapidly if a fire output is generated. Steady illumination indicates that the fire intensity has returned below the alarm threshold (i.e., fire has been extinguished).
2. The FIRE ZONE LEDs signal actuation of the corresponding Fire (timed) relay outputs.
3. Illumination of the ALARM LED indicates actuation of an Alarm (instant) relay output.
4. Illumination of the FAULT LED indicates a system malfunction (in Normal mode).
5. The POWER LED is illuminated when power is applied to the system.
6. The RESET/LAMP TEST button illuminates all LEDs for testing and also resets the system. While the button is depressed, the outputs are disabled. This will cause a fault condition until the controller restarts (approximately two seconds).
11. The TEST/NORM toggle switch selects NORMAL or TEST mode.

Normal Mode

In the Normal operating mode, the R7495B Controller monitors the outputs of all detectors connected to it and compares the detector output signals to field adjusted settings (refer to the "STAR Logic Programming" procedure in the "Programming the Controller" section) to determine whether a fire condition exists. Diagnostic circuitry continuously checks the system for wiring continuity as well as faults that could prevent proper response to a fire through the Automatic **oi** feature. The Fire Zone (timed) and Alarm (instant) relays are normally de-energized. The Fault relay is normally energized, as long as no system malfunctions are detected. Only the POWER LED is illuminated.

Resetting the Controller

Any existing system status indications and the controller outputs are returned to normal operating condition with all LEDs except the POWER LED off, and all relays except the Fault relay de-energize (after the radiation source is removed or the fault is corrected) in one of the following ways:

1. Depress the RESET/LAMP TEST button.

2. Place the mode switch in the TEST position, then return it to NORMAL.
3. Close the optional remote reset switch connected between terminals 31 and 32.

Programming Switches

Rocker switches that are located on the side of the controller are used for selecting various options available with the R7495B. These programming options are listed below and must be set prior to system operation. Refer to the "Programming the Controller" section of this manual for detailed instructions.

1. Number of detectors connected to the controller (up to eight)
2. Gate Length, Consecutive Gate Selection, Count Selection (system sensitivity and time delay).
3. Detector Grouping/Voting Logic
4. Latching/non-latching outputs.

Detector Grouping

The microprocessor-based circuitry in the controller requires that the detectors be "grouped" into detection zones. Two options are possible:

Separate - Two independent groups consisting of up to four detectors each (channels 1 to 4 and channels 5 to 8) can energize an Alarm and a Fire Zone output.

Combined - All eight channels make up a single detection zone, with both Alarm outputs and/or both Fire Zone outputs being actuated simultaneously.

Alarm Outputs

Two Alarm relays are provided for controlling external fire response devices. If any of the detectors in the group detects a fire that exceeds the gate length, consecutive gates, and count selection requirements.

1. One or both of the Alarm relays is energized.
2. Actuation of an Alarm relay is indicated by illumination of the ALARM LED on the front panel of the controller.
3. The detector(s) responding to fire is identified by illumination of its corresponding DETECTOR LED.

Fire Zone Outputs - If the combination of detectors responding to fire satisfies the pre-programmed voting

requirements, actuation of one or both of two Fire Zone outputs will also occur. If the controller is programmed for two separate zones, an output is generated if the selected number of detectors in the group (one or two) responds to fire. If an eight detector group is programmed, the controller energizes both Fire Zone outputs if fire is detected by the selected minimum number (one to four) of detectors.

This voting feature allows different combinations of detectors to fulfill the logic requirements, and provides the best balance between dependable fire detection and freedom from false alarms. Actuation of a Fire Zone output is signaled by illumination of the appropriate FIRE ZONE LED on the controller.

Ext Reset/Inhibit

Connecting a switch between terminals 31 and 32 allows the controller to be reset or inhibited from a remote location (close switch to inhibit/reset).

Fault Detection

The R7495B/C7052J system uses the Automatic oi feature to continuously check the cleanliness of the detector viewing windows and sensitivity of the sensors. In addition, automatic diagnostic circuitry in the controller monitors the system for wiring continuity faults as well as other malfunctions that could prevent the system from responding in the event of a fire. If a fault is detected:

1. The normally energized Fault relay is de-energized. This relay is typically used for controlling an external fault annunciation device or removing power from a hazardous process.
2. The FAULT LED on the front panel of the controller is illuminated to provide a visual indication that a system fault has occurred.

Field Wiring Connector

The R7495B Controller is furnished with a field wiring connector backplate that incorporates pressure type screw terminals for connecting the external wiring. The use of a Q4004 Mounting Cage is recommended for mounting the controller. The controller is designed for installation in a non-hazardous area.

SPECIFICATIONS

SPECTRAL SENSITIVITY RANGE—

UV: The UV sensor responds to radiation over the range of 0.185 to 0.245 microns (1850 to 2450 angstroms).

IR: The single frequency infrared sensor responds to radiation between 4.2 and 4.7 microns.

Figure 1 illustrates the spectral response range of the UV and IR sensors.

CONE OF VISION—

The C7052J has a 80 degree cone of vision with the highest sensitivity lying along its central axis. See Figure 4.

FLAME SENSITIVITY—

The C7052J5 with a part number DE5500 IR Sensor Module (the sensor part number is printed on its side) detects a 1 foot by 1 foot gasoline fire at 50 feet, a 2 foot by 2 foot JP4 fire at 100 feet, and a 10 foot by 10 foot JP4 fire at 150 feet.

The C7052J with a part number DE3895 IR Sensor Module (the sensor part number is printed on its side) detects a 1 foot by 1 foot gasoline fire at 35 to 45 feet, a 2 foot by 2 foot JP4 fire at 100 feet, and a 10 foot by 10 foot JP4 fire at 150 feet.

RESPONSE TIME—

The response time of the detector is a function of fuel, fire size, distance, orientation of the fire source and the field programmable controller settings. With typical controller settings of 0.25 second gate length, 4 counts per gate, and 4 consecutive gates, the system will respond to an intense fire signal in less than 2 seconds.

Response times of less than 1 second to an intense fire signal can be achieved by setting the controller for a 0.125 second gate length, 2 counts per gate, and 3 consecutive gates.

INPUT VOLTAGE—

Controller and Detector
24 vdc nominal (18 vdc minimum, 32 vdc maximum) with less than 1 volt of ripple.

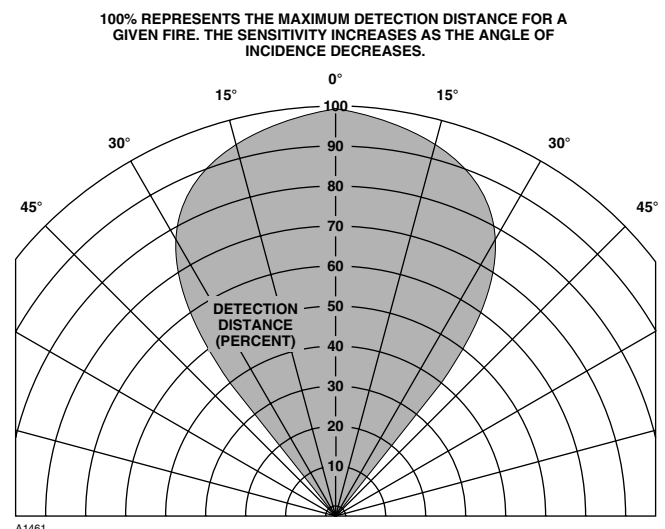

Figure 4—Cone of Vision

POWER CONSUMPTION—

Controller: 1.5 watts typical, 3.5 watts maximum.

Detector: 1.0 watt typical, 3.5 watts maximum.

RELAY CONTACT RATINGS—

3 amperes at up to 30 vdc or up to 240 vac

CONTROLLER TEMPERATURE RANGE—

Operating: +32°F to +140°F (0°C to +60°C)

Storage: -40°F to +140°F (-40°C to +60°C)

DETECTOR TEMPERATURE RANGE—

Operating: -40°F to +167°F (-40°C to +75°C)

Storage: -67°F to +185°F (-55°C to +85°C)

DETECTOR HUMIDITY RANGE—

0 to 95% relative humidity.

DETECTOR ENCLOSURE MATERIAL—

Copper-free aluminum (red) or 316 stainless steel, with optional stainless steel mounting bracket.

DETECTOR ENCLOSURE RATINGS—

FM approved and CSA certified for Class I, Groups C and D, and Class II, Groups E, F, and G hazardous locations. NEMA 4 enclosure. BASEEFA/CENELEC certified flame-proof for EExd IIB T6; IP66 enclosure rating.

RFI/EMI HARDENED—

Detector designed to meet RFI and EMI immunity requirements of MIL STD 461, 462, and 463.

DIMENSIONS—

See Figures 5, 6, 7 and 8.

SHIPPING WEIGHT—

R7495B Controller:

4.4 pounds (2.0 kilograms)

C7052J Detector:

Aluminum: 6.0 pounds (2.7 kilograms)

Stainless Steel: 14.0 pounds (6.4 kilograms)

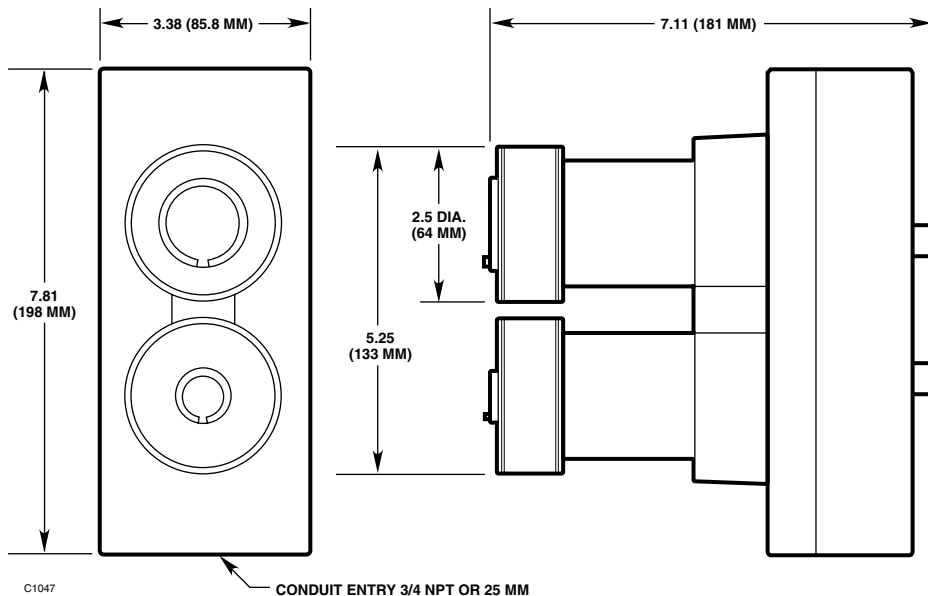

Figure 5—Detector Dimensions in Inches (MM)

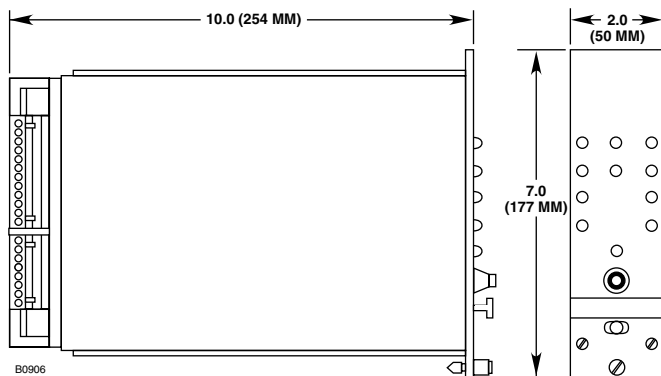

Figure 6—R7495 Controller Dimensions in Inches (MM)

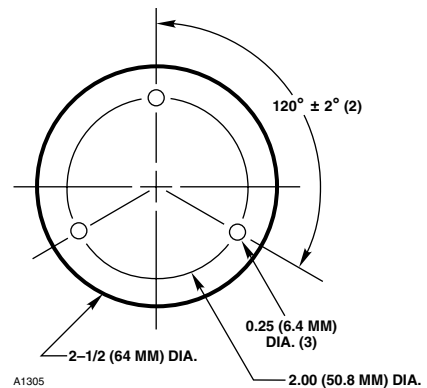

Figure 7—Mounting Base Dimensions

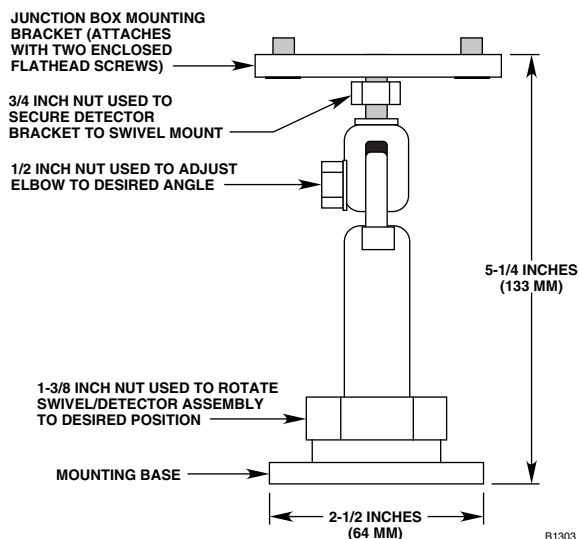

Figure 8—Q9001G Swivel Mounting Bracket Dimensions

OPTIONS

Power supplies are available for operating the R7495B and C7052J from line (mains) voltage.

Q4004 Mounting Cage is designed for holding up to eight micro-module devices and is recommended for ease of installation and servicing. Mounting cages that hold fewer modules are also available. Optional filler panels (part number 002188-001) can be used to cover unused sections of the mounting cage.

Locking devices must be used on detector housings to comply with applicable regulations in some areas (BASEEFA/CENELEC).

Q1113 Air Shields for areas where there is an abnormally high level of airborne contaminants. Two Q1113 Air Shields are required for each detector.

Q9001G Swivel Assembly (part number 004404-001) for easy mounting and sighting of detector assemblies.

RESPONSE CHARACTERISTICS

The response time of the detector is a function of fuel, fire size, distance, orientation of the fire source and the field programmable controller settings. As with all fire tests, results must be interpreted according to the individual application, taking into account all possible variables (see the Application Guidelines” section for a discussion of of these factors).

Typical response distances of the C7052J Detector to various fuels are listed in Table 1. Each liquid fuel fire (acetone, diesel, gasoline, methanol, and toluene) consisted of approximately one pint of fuel burned in a 1 foot by 1 foot steel pan unless otherwise noted. The

excelsior (wood shaving) fire consisted of one pound of wood shavings. The wood fire consisted of a 10-inch by 10-inch crib (wood stack). The methane fire was performed to FM standard, with the flame approximately 30 inches high and 6 to 8 inches in diameter. The detectors were sited to observe the fire at center axis ± 10 degrees. The controller sensitivity and time delay settings were 4 counts per gate, 4 consecutive gates, and 0.25 second gate lengths.

APPLICATION GUIDELINES

Certain guidelines must be followed when using any type of sensing device as a fire detector. This involves not only recognizing the strengths and advantages of a particular device, but also understanding its limitations.

It is also important to note that in any system that uses two or more sensors to produce a fire signal, the detector will be disabled should one of its sensors fail. The Automatic Oi feature will warn of such failure. Routine manual testing and checking of the system is recommended for increased system reliability.

Potential radiation sources in the environment must also be carefully considered. A UV sensor will respond to sources of UV besides fire, such as electric arc welding, lightning, x-rays and gamma radiation. The C7052J has been designed to ignore steady state infrared sources that do not have a flicker frequency characteristic of a fire, however, it should be noted that if these steady state infrared sources are hot enough to emit adequate amounts of infrared radiation in the response range of the IR sensor and if this radiation becomes interrupted from the view of the detector in a pattern characteristic of a flickering flame, the IR sensor can respond. Any object having a temperature greater than 0° Kelvin (–273°C) emits infrared radiation. The hotter the object, the greater the intensity of the emitted radiation. See Figure 9. The closer the infrared source is to the detector, the greater the potential for the IR sensor to produce

Table 1—C7052J Typical Response Distances

Fuel	Distance from U7652
Acetone	45 feet (13.7 meters)
Diesel	40 feet (12.2 meters)
Gasoline	50 feet (15 meters)
Methane	35 feet (10.7 meters)
Methanol	35 feet (10.7 meters)
Toluene	50 feet (15 meters)
Wood Shavings (Excelsior)	50 feet (15 meters)
Wood Stack (Crib)	50 feet (12.2 meters)
JP4 (surface area)	
2 ft ²	100 feet (30 meters)
4 ft ²	150 feet (45 meters)
10 ft ²	150 feet (45 meters)

an alarm. The IR sensor can respond to IR radiation sources that can meet the amplitude and flicker requirements of the detector such as vibrating hot objects. Although the C7052J Detector is designed to reduce false actuations, certain combinations of ambient radiation must be avoided. For example, if IR radiation with an intensity that exceeds the fire threshold of the IR sensor should reach the detector as a flickering signal, and if at the same time an electric arc welding signal also reaches the sensors, an alarm output will be generated.

The C7052J ignores arc welding beyond 15 feet from the detector. However, the UV sensor will respond to the intense UV radiation generated by the arc welding, and at distances closer than 15 feet the heated metal from the welding can become a false alarm source for the IR sensor.

Another important fact regarding a radiation detector of any type is that radiation must reach the detector in order for it to respond. Care must be taken to keep physical obstructions out of the line of view of the detector. In addition, UV or IR absorbing gases or vapors must not be allowed to accumulate between the detector and the protected hazard. See Table 2 for a listing of these substances. Smoke will also absorb radiation, therefore, the detector should not be mounted close to the ceiling or other areas where smoke can accumulate.

It is important to keep the detector viewing windows as free of contaminants as possible in order to maintain maximum sensitivity and to assure proper operation of the flame detection system. Commonly encountered substances that can significantly attenuate UV and/or IR radiation include, but are certainly not limited to, the following:

- Silicones
- Oils and greases
- Ice buildup
- Dust and dirt buildup
- Paint overspray

The **oi** test feature is designed to register an **oi** fault when the detector sensitivity is reduced to approximately 50% of its maximum detection range. For maximum system reliability, it is recommended that the detector viewing windows be cleaned on a regularly scheduled basis. (Refer to the "Maintenance" section of this manual for additional information regarding detector maintenance.) The use of model Q1113 Air Shields can help extend the time period between required maintenance.

The C7052J is designed to be resistant to interference from EMI and RFI. It will not respond to a 5 watt walkie-talkie at a distance of greater than 1 foot.

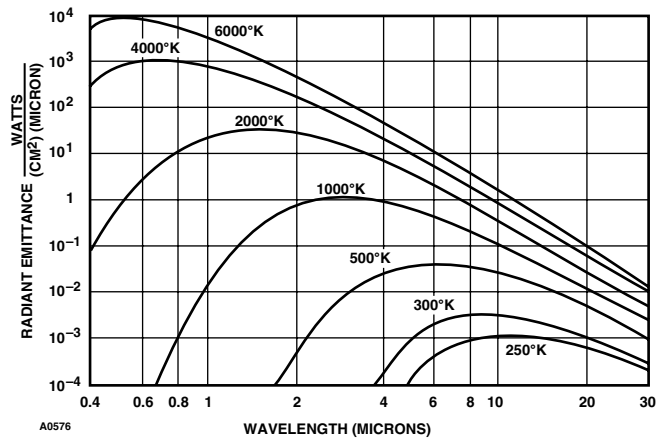

Figure 9—Blackbody Spectral Emittance

Table 2—Radiation Absorbing Gases and Vapors

The following is a partial list of compounds that exhibit significant UV absorption characteristics. These are also usually hazardous vapors. While generally of little consequence in small amounts, these gases can restrict UV detection if they are in the atmosphere in heavy concentrations. It should also be determined whether or not large amounts of these gases may be released as a result of a fire-causing occurrence.

Acetaldehyde	Methyl Methacrylate
Acetone	Alpha-Methylstyrene
Acrylonitrile	Naphthalene
Ethyl Acrylate	Nitroethane
Methyl Acrylate	Nitrobenzene
Ethanol	Nitromethane
Ammonia	1-Nitropropane
Aniline	2-Nitropropane
Benzene	2-Pentanone
1,3 Butadiene	Phenol
2-Butanone	Phenyl Glycide Ether
Butylamine	Pyridine
Chlorobenzene	Hydrogen Sulfide
1-Chloro-1-Nitropropane	Styrene
Chloroprene	Tetrachloroethylene
Cumene	Toluene
Cyclopentadiene	Trichloroethylene
O-Dichlorobenzene	Vinyl Toluene
P-Dichlorobenzene	Xylene

If UV-absorbing gases may be a factor in a given application, precautionary measures should be taken. Detectors can be placed closer to the potential hazard area, and/or the sensitivity of the detection system can be increased. Contact the factory for further details.

Substances such as methane, propane, butane, hexane, camphor and octane are not UV absorbing.

Absorption of infrared radiation in the range of 4.2 to 4.7 microns is not a significant problem with most organic vapors, with the exception of those compounds that have triple bonds such as acetylene, nitriles, silane, or isocyanates. Carbon dioxide concentrations higher than normally present in the atmosphere can also cause substantial loss of fire detection sensitivity.

The C7052J uses a single frequency IR sensing device with detection limited to the hot CO₂ emission peak, therefore, it cannot be used to detect fires that do not contain carbon, such as hydrogen, sulfur, burning metals, or other non-hydrocarbons without thorough testing.

INSTALLATION

Detector Positioning

When determining the proper number and positioning of detectors needed for adequately protecting any given installation, it is essential to consider the cone of vision of the detector. The C7052J Detector has a nominal 80 degree cone of vision with the highest sensitivity along its central axis. Refer to Figure 4. Careful observation of this graph reveals that at 50 percent of the maximum detection distance, the cone of vision is still 80 degrees. As the detection distance increases beyond 50 percent, the cone of vision gradually decreases. For example, the C7052J will detect a 1 foot by 1 foot gasoline fire at 50 feet. Therefore, we can assume that at 25 feet (50% maximum distance) the cone of vision will be 80 degrees. If the fire increases in size, both the maximum detection distance and the cone of vision at longer distances will be increased.

It is also important to note that as the distance increases between the detector and the fire source, the time needed for the detector to respond to a fire of a given size also increases (fastest response requires maximum fire signal). The intensity of the radiation reaching the detector decreases with distance. For fastest response time, locate the detector as close as possible to the anticipated fire source.

The following recommendations should be observed in designing or installing any fire detection system:

- Use enough detectors to adequately cover the protected area with overlapping cones of vision.
- For fastest response time, position the detectors as close as possible to the anticipated fire source.
- Aim the detector as directly as possible at the anticipated fire source.
- If possible, conduct actual flame tests to verify correct detector positioning and proper system operation.

Whenever possible, the detector should be positioned in a manner that will minimize the buildup of contaminants on the viewing window and **oi** ring. Substances such as snow, ice, dirt, oil, paint overspray, and numerous other commonly encountered materials are capable of attenuating UV or IR radiation and adversely affecting detector response.

For outdoor applications, the detector should be aimed downward to minimize the buildup of water or ice on the detector viewing window and to prevent it from scanning the horizon. This minimizes the response to distant radiation sources outside the protected area.

The detector should not be placed where smoke can obscure its view of the hazardous area. For indoor applications, if dense smoke is expected to accumulate at the onset of a fire, mounting the detector on a side wall a few feet (1 meter) down from the ceiling will normally allow enough time for the unit to respond before it is affected by rising smoke. The detector should be located where it can be easily accessed for periodic maintenance, testing and cleaning.

Wiring Requirements

The system should be wired using four conductor shielded cable, at least 18 gauge (1.024 mm diameter). The length of cable should be considered when wiring the system to ensure that a minimum input voltage of 18 vdc is present at the detector. The cable length should not exceed 2000 feet. In applications where the wiring cable is installed in conduit, the conduit should not be used for wiring to other electrical equipment. Foil type shielded cable is recommended to protect from electromagnetic and radio frequency interference. When using cables with shields, the shield should be insulated at the detector and grounded only at the control cabinet.

NOTE

It is important to use cable that is suitable for the installation environment. In applications involving high humidity or salt water, use a cable that is made specifically for harsh, salt water environments. In all cases, typical cable insulation resistance should be at least 100 megohms. If the resistance drops below 10 megohms, the cable could be deteriorating and should be replaced to avoid shorting. When testing the insulation resistance, disconnect the leads from the detector/controller before connecting the megohmmeter (insulation tester) to the cable.

Since moisture can be detrimental to electronic devices, it is important that moisture not be allowed to come in contact with the electrical connections of the system. Moisture in the air can become trapped within sections of conduit, therefore the use of conduit seals is required to prevent damage to electrical connections caused by condensation within the conduit. These seals must be water-tight and explosion-proof and are to be installed even if they are not required by local wiring codes. A seal must be located as close to the C7052J as possible. In no case should this seal be located more than 18 inches (46 cm) from the unit. If a conduit swivel is

used, the seal must be located between the swivel and the detector. When an explosion-proof installation is required, an additional seal must also be installed at any point where the conduit enters a non-hazardous area. When pouring a seal, the use of a fiberdam is required to assure proper formation of the seal. The seals should never be poured in temperatures that are below freezing, since the water in the sealing compound will freeze and the compound will not dry properly. Contamination problems can then result when temperatures rise above the freezing point and the compound thaws. The shielding of the cable should be stripped back to permit the seal to form around the individual leads, rather than around the outside of the shield. This will prevent any siphoning action that might occur through the inside of the shield. The electrical continuity of the shield must be maintained through the seal via the shield drain wire.

Moisture in the air can be trapped within sections of conduit and can condense and accumulate at the base of vertical conduit runs. To eliminate this condition, explosion-proof drains and breathers should be installed to automatically bleed off accumulated water.

It is recommended that the detector be oriented with the conduit opening at the bottom or at either side of the device. This will reduce the possibility of moisture entering the junction box through the conduit entry and also ensure that the **o**i test lamps are not in a position that would make the detector overly susceptible to **o**i

faults. Whenever possible, slope the conduit run downward from the detector. Do not use conduit runs that enter the device from the top. See Figure 10 for identification of the detector parts of interest when mounting, and Figure 11 for an example of vertical detector mounting.

Detector Mounting and Wiring Procedure

The following procedure should be used for mounting and wiring the C7052J.

1. Detectors should be located in positions best suited for covering the area to be protected. Whenever practical, they should be placed where they will be easily accessible for cleaning and other periodic servicing. Particular attention should also be paid to potential false alarm sources within the cone of vision of the detector, such as distant arc welding, rotating fan blades, surface vibration of an IR source, and movement of people or machines between the detector and an IR source, all of which could allow a flickering IR signal to reach the detector. Rain or ice can absorb radiation, which can reduce the capability of the detector. For outdoor applications, aim the detector downward to minimize the buildup of water or ice on the detector viewing windows and to prevent the cone of vision from scanning the horizon. This minimizes response to distant radiation sources outside the protected area.

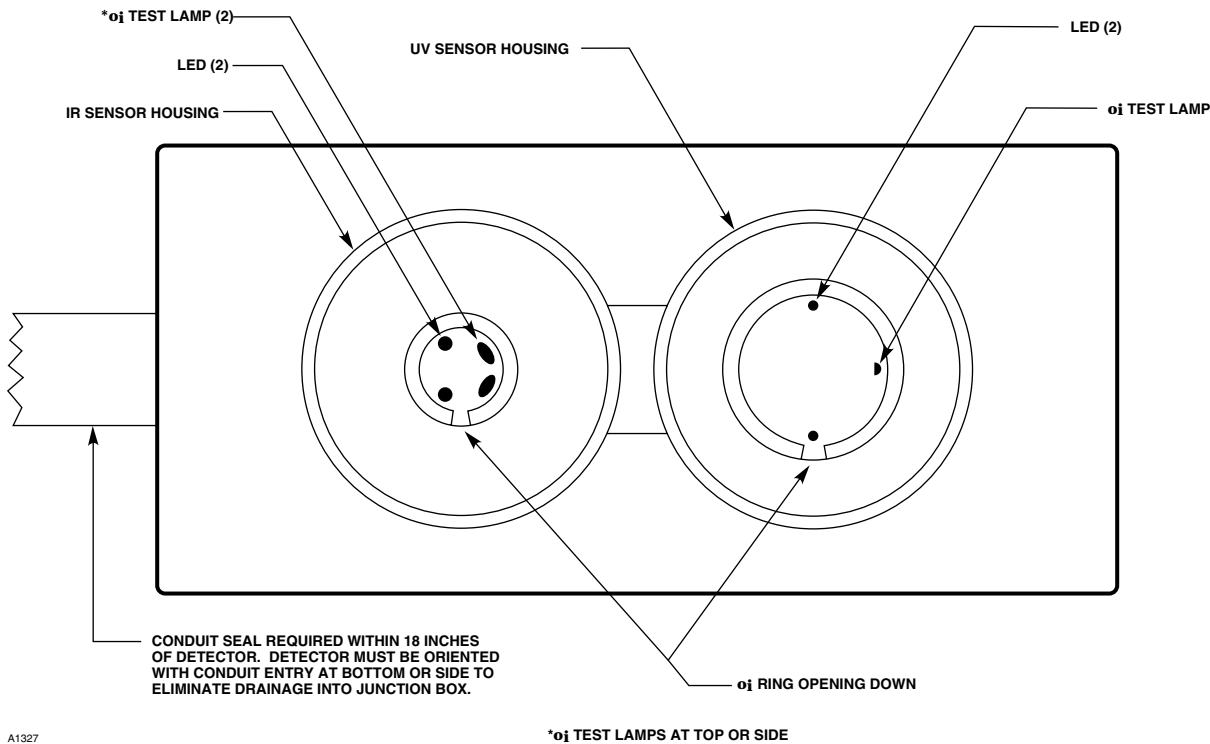

Figure 10—Front View of the C7052J Detector

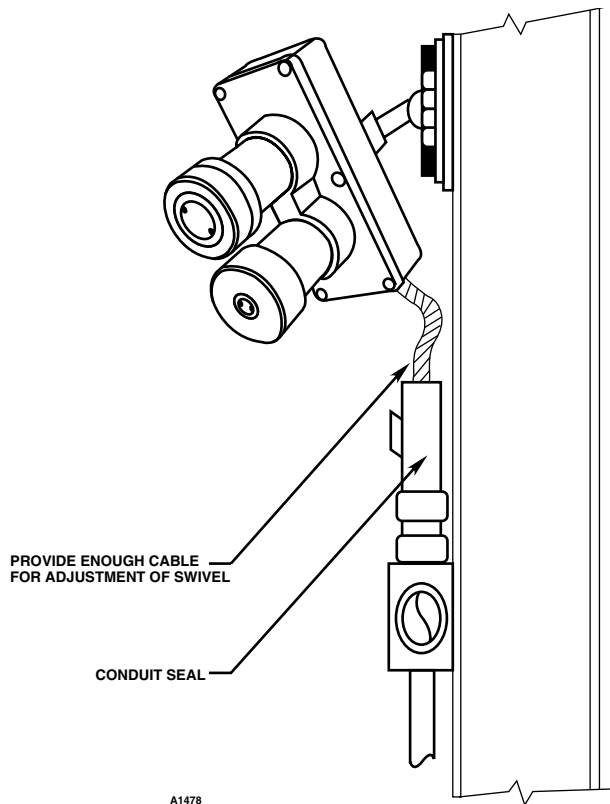

Figure 11—Vertical Mountign Detector

NOTE

The wiring procedures in this manual are intended to ensure proper functioning of the device under normal conditions. However, because of the many variations in wiring codes and regulations, total compliance to these ordinances cannot be guaranteed. Be certain that all wiring complies with applicable regulations that relate to the installation of electrical equipment in a hazardous area. If in doubt, consult a qualified electrician before wiring the system.

2. Remove the junction box cover assembly from the base by loosening the six screws on the cover (see Figure 12).
3. Mount the detector junction box base and mounting bracket assembly on the wall or ceiling. See Figures 7 and 8 for dimensions of the mounting bracket. The mounting surface should be free of excessive heat and vibration.

NOTE

Do not wire the system, or plug in or remove the sensor modules with power applied.

4. Figure 13 shows the detector terminal block. Letter designations correspond to connections as indicated below.

- A = +24 vdc
- B = detector output signal
- C = circuit ground
- D = Oi control signal

Minimum requirements for wiring the detector are for the B-lead (signal) to be shielded. It is preferred that the A-lead, C-lead, and D-lead also be shielded to provide maximum immunity to EMI/RFI. The wiring procedure below is the preferred method of detector to controller wiring. Refer to Figure 14 for an example of a typical application showing detector to controller wiring.

- a. Connect the B-lead shields to the chassis (earth) ground connection (terminal 5) of the controller.
 - b. Be certain that the shield is NOT connected to the detector at terminal "C" (circuit ground) or any other points.
 - c. Connect the C-leads of the detectors to terminal 2 (circuit ground) of the controller.
 - d. Connect a non-polarized 0.47 microfarad 250 vdc capacitor from terminal 5 to terminal 2. This places the earth ground and the circuit ground at the same ac potential, minimizing induction of noise into the system through the detector cable.
5. Check to make sure that all wiring is correct. If conduit is used, pour the conduit seals and allow them to dry.
 6. If the UV and/or IR sensor modules are already installed in the detector housing, proceed to step 12. If the sensors are not installed, remove the applicable sensor housings from the junction box cover (see Figure 12). If the detectors are equipped with a cover locking device (see Figure 15), loosen the clamp and disengage the "catch" from the blind hole. The tool required is a 5/32-inch hexagonal (Allen) wrench.
 7. If the UV sensor module is already installed, proceed to step 9. If the UV module is not installed, remove the UV sensor module from its shipping package.
 8. Determine the proper orientation for the UV module by lining up the long index pin on the terminal block with the hole in the printed circuit board of the module. See Figure 12. Firmly press the module into place on the terminal block, taking care not to touch the glass envelope of the sensor module, since fingerprints can absorb UV radiation and reduce the sensitivity of the sensor.

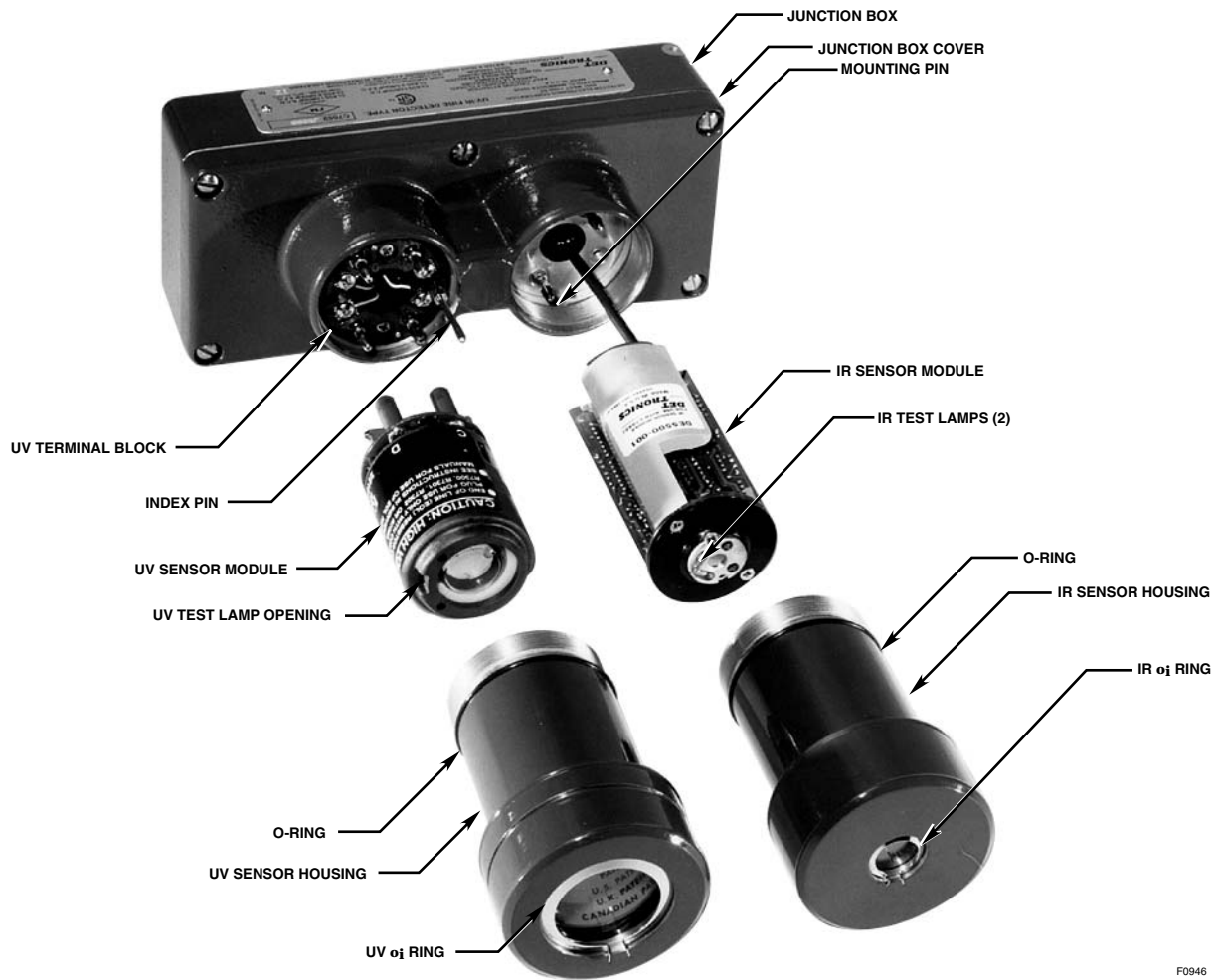

F0946

Figure 12—C7052J Detector Part Identification

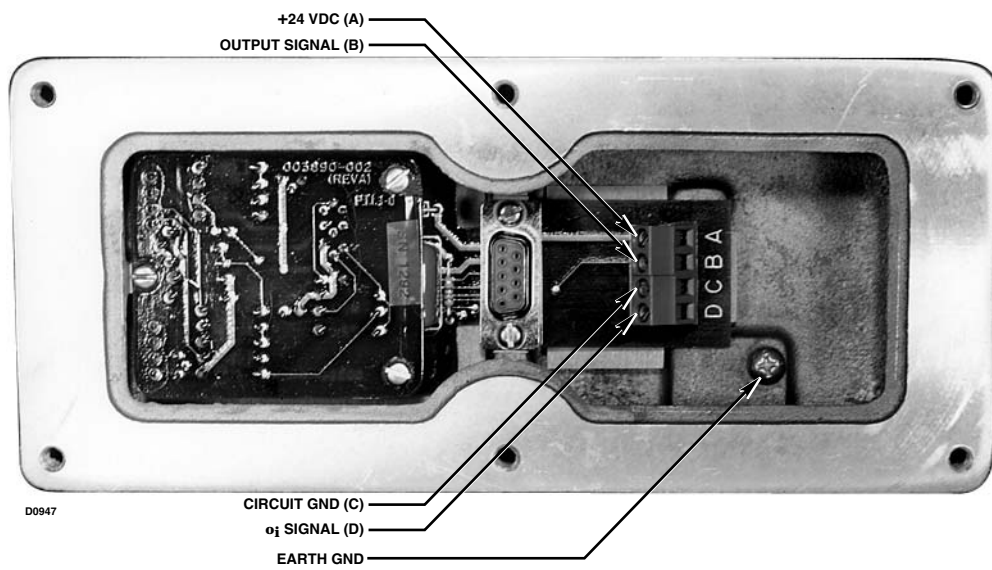

D0947

Figure 13—Detector Terminal Block

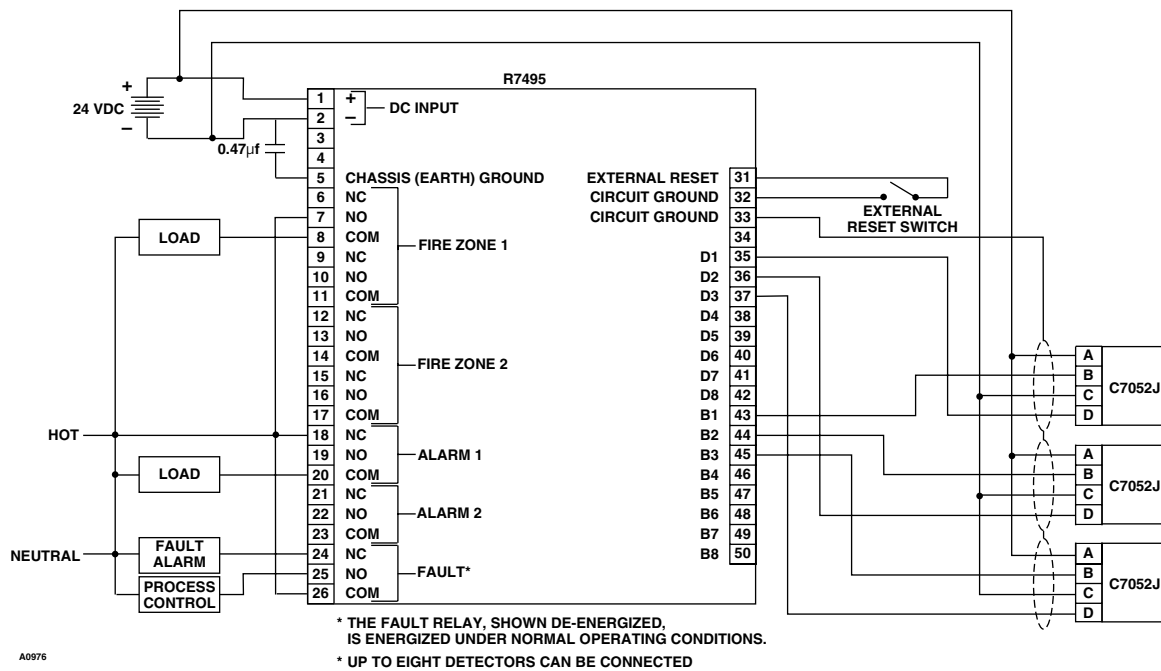

Figure 14—Typical Application Wiring

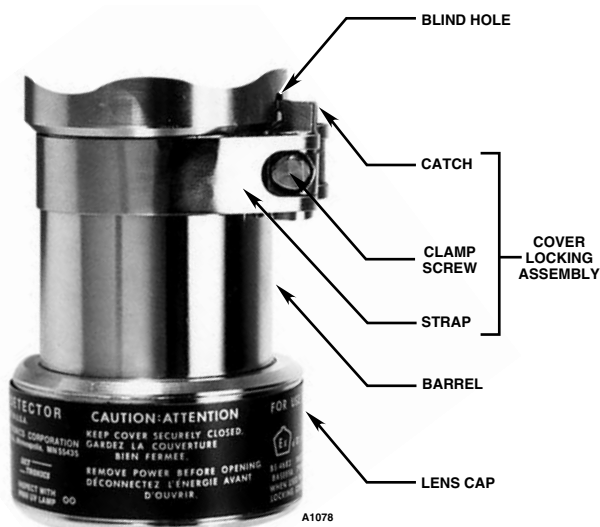

Figure 15—Cover Locking Assembly (Optional)

IMPORTANT

If the UV sensor module is supplied with a jumper plug “J” as shown in Figure 16, remove the jumper plug from the detector tube module and discard it. Jumper plug “J” is supplied for installations in which the tube module is used with other detector models.

NOTE

The C7052J contains semiconductor devices that are susceptible to damage by electrostatic discharge. An electrostatic charge can build up on the skin and discharge when an object is touched. Therefore, use caution when handling the detector,

taking care not to touch the terminals or electronic components. For more information on proper handling, refer to Service Memo form 75-1005 at the front of this manual.

9. If the IR sensor is already installed, proceed to step 12. If the IR sensor is not installed, remove the IR module from its shipping package (avoid touching the IR sensing element at the top of the module). Two IR sensor designs exist; the DE5500 is electrically connected via a wire harness on the junction box that must be threaded through the sensor module to a connector at the top of the module (see Figure 17), the DE3895 plugs directly onto a terminal block in the base of the IR housing via connectors on the bottom of the IR sensor module (see Figure 12).
10. If the IR sensors are the DE3895 type that electrically connects directly onto the terminal block, install them by lining up the connection pins using the index pin to properly orient the module. Press the sensor firmly into place.
11. If the IR sensor is the DE5500 type that connects via a wire harness (Figure 17), thread the wire leads and keyed connector plug through the slotted opening on the side of the IR module. Plug the IR module into the two banana plugs inside the junction box cover. If repositioning is necessary to properly align the **o**i lamps (as described in the “NOTE” below), this module can be rotated 180° and remounted on the banana plugs.



Figure 16—Jumper Plug

NOTE

The two **o_i** lamps on the DE5500 IR sensor should be at the top or side of the detector (when viewed from the front) and the opening on the **o_i** ring should be at the bottom. See Figure 10. This will ensure proper operation of the **o_i** system and also minimize the accumulation of moisture and contaminants between the **o_i** ring and the viewing window. (The **o_i** lamps on the IR sensor are identified as oblong in shape and clear in color.)

12. Connect the keyed connector plug to the 4-pin connector on the DE5500 IR module. Tuck the leadwires inside the module to prevent binding or wire damage when installing or removing the sensor housing.
13. Check the O-rings on both sensor housings to be sure that they are in good condition and are fitted properly, then re-install the sensor housings on the junction box cover. (See the "Maintenance" section of this manual for information regarding care of O-rings.) The sensor housing with the large viewing window is for the UV detector and the sensor housing with the small window is for the IR detector. Hand tighten the sensor housings into the base until the O-rings are fully seated to maintain the explosion-proof and watertight integrity of the housing. If the unit is equipped with cover locking clamps, loosen the clamps sufficiently so that the clamp catches can be seated in the blind holes on the junction box cover. Fasten the clamps securely using a 5/32 inch hexagonal (Allen) wrench. (See Figure 15.)
14. Re-install the junction box cover, making sure that the center nine-pin connector on the cover is properly aligned with the connector in the junction box.

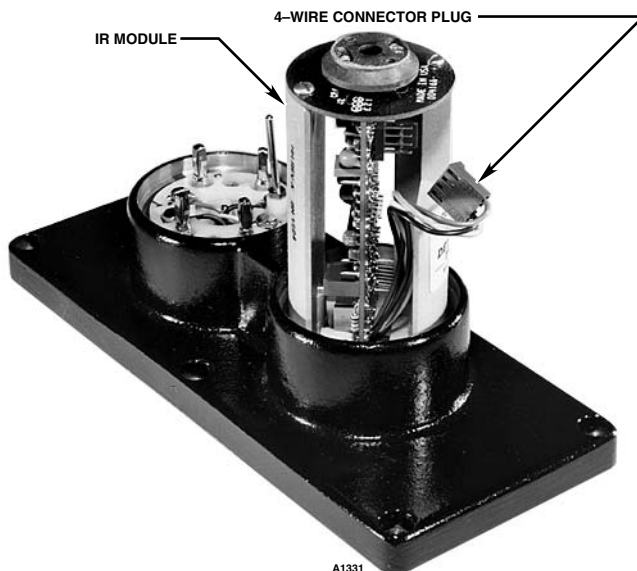

Figure 17—IR Module with Four-Wire Connector

The six screws must be tight to ensure a metal to metal fit to maintain explosion-proof and watertight integrity of the junction box.

15. Inspect and clean (if necessary) the detector viewing windows and **o_i** rings by following the instructions in the "Maintenance" section of this manual.
16. The opening of the **o_i** rings should be pointed down to minimize the accumulation of moisture or contaminants behind the ring (see Figure 10). Verify that the **o_i** test lamp is at the top or side of each sensor. Note that Figure 10 shows the DE5500 IR module with the test lamps located together on one side of the edge. The DE3895 IR module has test lamps located directly opposite one another. In both cases, ensure that no test lamp is positioned at the bottom when the detector is installed.
17. If the detector is so equipped, install the air shields on each sensor housing, then connect the air supply line to the air shields.

NOTE

Be sure that the detector is correctly aimed at the potential hazard and that no obstructions interfere with its line of vision. In addition, UV and/or IR absorbing gases (see Table 2) should not exist between the detector and the potential hazard.

CONTROLLER INSTALLATION AND WIRING

The R7495B Controller must be mounted in a non-hazardous area. The optional Q4004 Mounting Cage is designed to hold up to eight modules in a 19 inch instrument rack. Other mounting cages are available to accommodate 1, 2, 3, 4 or 6 units. These mounting

cages can also house voltage converters and other micro-module equipment that is used in conjunction with the R7495B Controller as part of the total protection system. See Figure 18 for illustration and dimensions.

Electrical Connections

All electrical connections are made to the field wiring connector that is furnished with the controller. Figure 19 shows the terminal configuration for the controller. Power to the R7495B Controller and C7052J Detectors may be furnished by external 24 volt batteries, a regulated dc power supply, or optional Det-Tronics voltage converters.

- | | | | |
|--------------|--|-----------------------|--|
| Terminal 1 — | Connect to the positive (+) side of an external 24 vdc power source. | Terminal 5 — | Chassis (earth) ground terminal is connected to the controller chassis and should be connected to the nearest earth ground connection. |
| Terminal 2 — | Connect to the negative (-) side of the dc power source (circuit ground). The C terminals on the detectors must also be connected to circuit ground. | Terminals 6 to 11 — | Relay Contacts, Fire Zone 1. |
| Terminal 3 — | Do not use. | Terminals 12 to 17 — | Relay Contacts, Fire Zone 2. |
| Terminal 4 — | Do not use. | Terminals 18 to 20 — | Relay Contacts, Alarm 1. |
| | | Terminals 21 to 23 — | Relay Contacts, Alarm 2. |
| | | Terminals 24 to 26 — | Fault relay contacts- the fault relay is normally energized in the Normal mode with no system faults present. |
| | | Terminals 31 and 32 — | External Reset - a normally open switch connected between terminals 31 and 32 (circuit ground) allows the controller to be reset from a remote location. |
| | | Terminal 33 — | Circuit ground - connect to all detector wiring shields. |

RACK TYPE	PART NUMBER 005269-XXX	CONTROLLER POSITIONS FOR:		HT:	DIM. (A)		DIM. (B)		DIM. (C)		DIM. (D)		DIM. (E)		WEIGHT	
		FIRE	GAS		INCH	MM	INCH	MM	INCH	MM	INCH	MM	INCH	MM	LB	KG
4U	-001	8	16	4U	19.00	482.6	18.30	464.8	17.36	440.9	4.00	101.6	6.97	177.1	9.3	4.2
4U	-002	6	12	4U	15.06	382.6	14.36	364.7	13.42	340.9					7.6	3.5
4U	-003	4	8	4U	11.13	282.6	10.43	264.9	9.49	241.1					5.9	2.7
4U	-004	3	6	4U	9.16	232.7	8.46	214.9	7.52	191.0					5.1	2.3
4U	-005	2	4	4U	7.19	182.7	6.49	164.9	5.55	141.0					4.2	1.9
4U	-006	1	2	4U	5.22	132.6	4.52	114.8	3.58	90.9					3.1	1.4

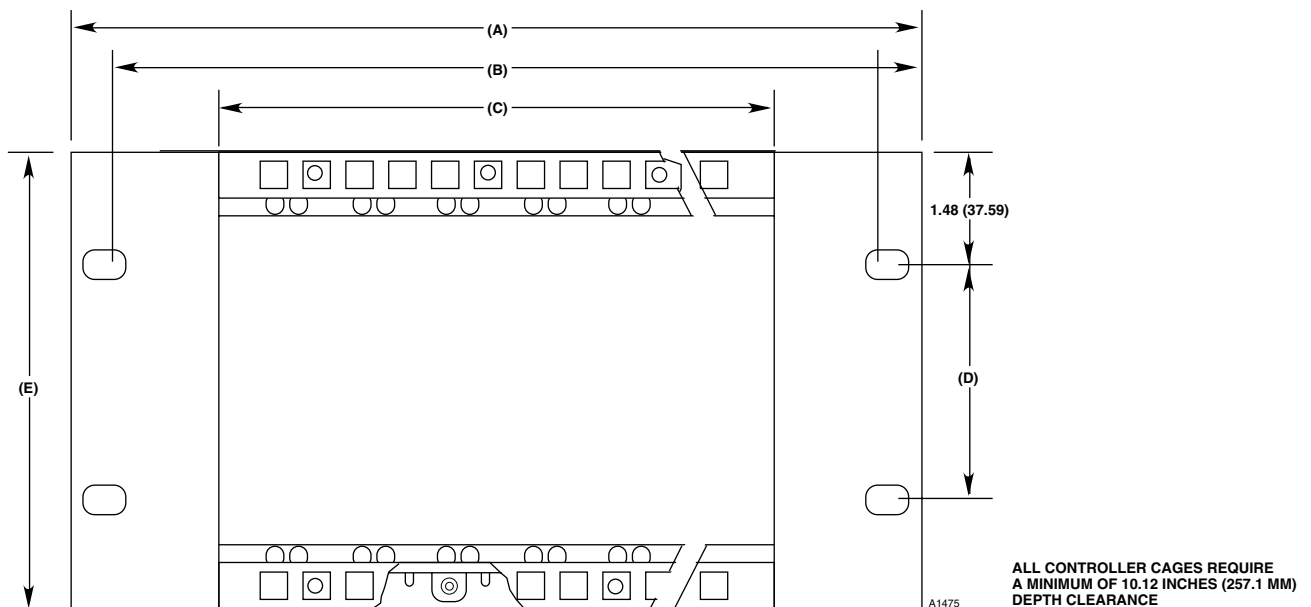

Figure 18—Q4004 Mounting Cage Dimensions in Inches (MM)

- Terminal 34 — Do not use.
- Terminals 35 to 42 — Connect to the D-leads (oi control signal) of the corresponding detectors.
- Terminals 43 to 50 — Connect to the B-leads (detector output) of the corresponding detectors.

PROGRAMMING THE CONTROLLER

The R7495B Controller is field programmable in order to meet the requirements of the individual installation. This is accomplished by setting rocker switches that are located on the left side of the controller (see Figure 20) to either “open” or “closed.” The programming options are listed below. A more detailed description follows.

1. Number of detectors connected to the controller (up to eight)
2. Gate Length, Consecutive Gate Selection, and Count Selection (system sensitivity and time delay).
3. Detector Grouping/Voting Logic
4. Latching/non-latching outputs.

The individual rocker switches are identified by numbers 1-1, 1-2, 1-3, etc. in this manual. The number preceding the dash indicates the number of the switch assembly. The number following the dash identifies the specific rocker on the switch assembly. See Figure 20.

Each rocker switch assembly contains eight separate rocker switches. The rockers are identified by the numbers one through eight on one side of the assembly. The word “open” can be seen on the opposite side. The switch is open when depressed in the direction of the word “open” and closed when depressed in the direction of the numbers.

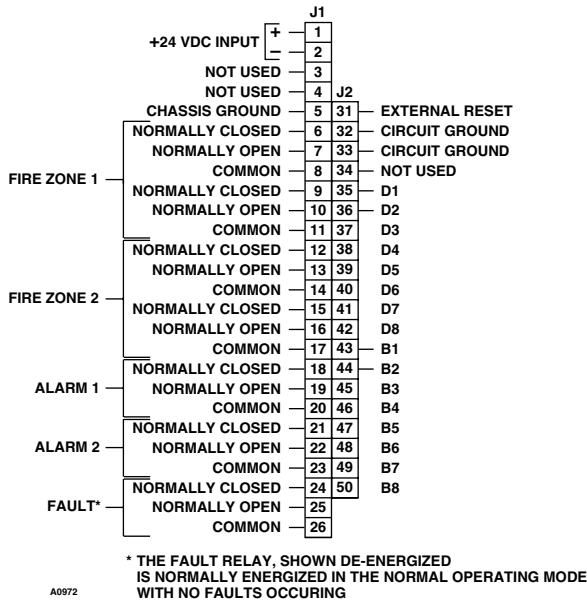

Figure 19—Terminal Configuration

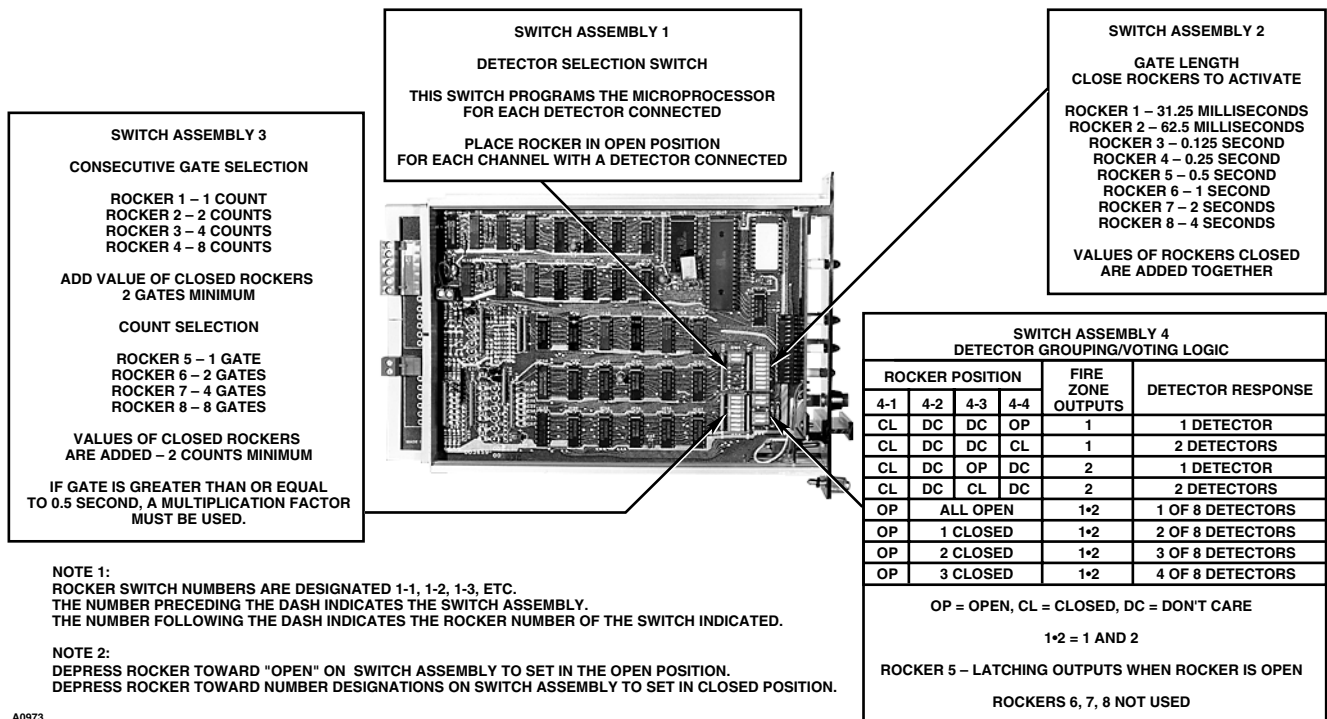

Figure 20—Rocker Switch Setting

The rocker switches must be set before power is applied to the system. Do not plug the controller in or remove it from the mounting rack while power is turned on.

CAUTION

Use care when setting the rocker switches on the controller. An incorrectly set rocker switch can result in an obvious controller malfunction, or the controller could appear to be functioning normally, but not produce the desired output in response to the input conditions. (Some of the rocker switches on the R7495B are not used. These rockers should be left open.)

Detector Selection - Rocker Switches 1-1 to 1-8

The number after the dash corresponds to the number of each zone. Open the rocker for each zone that has a detector connected to it. Care must be taken when setting these rockers. If a rocker is set open, but no detector is connected in that location, the controller will indicate a fault. If a rocker is set closed when a detector is connected, the controller will appear to be operating correctly and will produce an alarm condition if the corresponding detectors sense a fire. However, that detector will be eliminated from the Automatic **o**i test sequence, and any faults occurring in its circuitry or wiring will not be indicated.

STAR Logic Programming (System Sensitivity and Time Delay) - Rocker Switches 2-1 to 2-8 (Gate Length), Rocker Switches 3-1 to 3-4 (Count Selection Per Gate), and Rocker Switches 3-5 to 3-8 (Consecutive Gates Selection).

The STAR Logic switch settings determine system sensitivity and time delay. The most important factor in determining the appropriate sensitivity setting for a particular application is the intensity of radiation expected to reach the detector in the event of a fire. This depends on several factors, including the distance of the detector from the potential fire, the fuel type, the flame size, and whether any radiation absorbing vapors are present (these are listed in Table 2).

The most effective way to set system sensitivity is to install the system, program the STAR Logic according to the typical settings shown in Figure 21, program all other aspects of controller operation according to this section (“Programming the Controller”), then perform the “Initial and Periodic Checkout Procedure” using a UV/IR test lamp and the “STAR Programming Checkout Procedure.”. If the system fails to respond appropriately during these tests and all system wiring is correct, then system sensitivity (gate length, counts per gate, and consecutive gates) needs to be adjusted. It is important that all wiring and programmed settings be checked to ensure that they are correct before adjusting these settings.

R7495 STAR Logic Program	R7495 Switch Settings	
	Rockers Closed	Rockers Open
4 Counts per Gate	3-3	3-1, 3-2, 3-4
0.25 Second Gate Length	2-4	2-1, 2-2, 2-3, 2-5, 2-6, 2-7, 2-8
4 Consecutive Gates	3-7	3-5, 3-6, 3-8

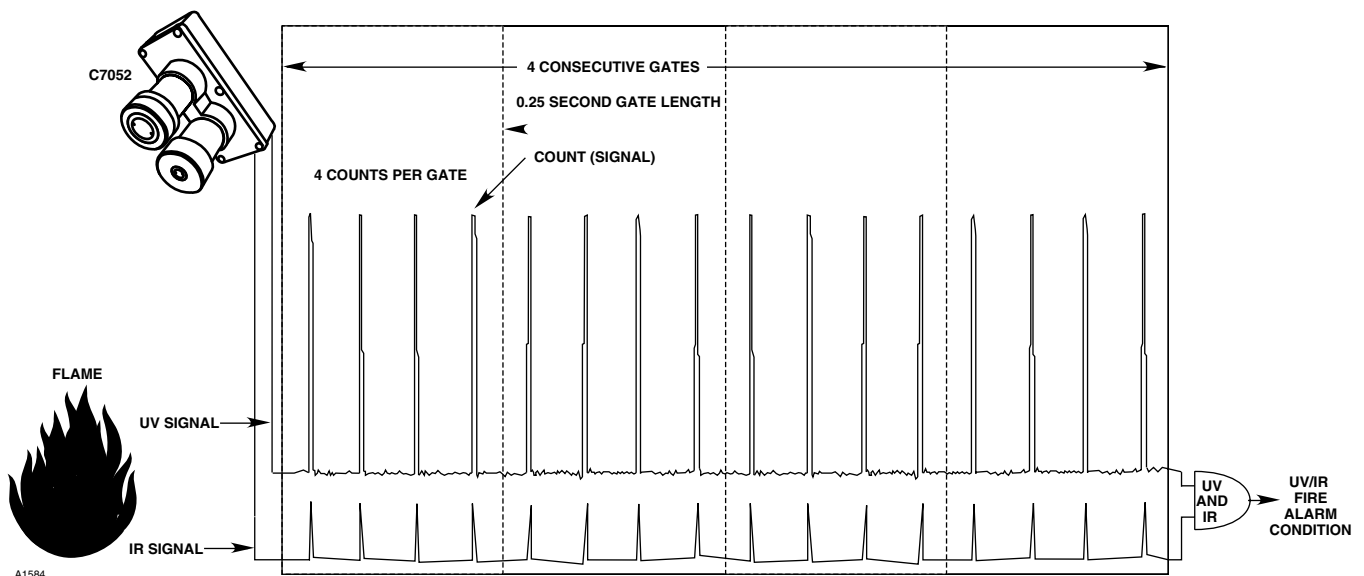

Figure 21—Graphic Representation of STAR Logic (Typical Setting Shown)

Rocker switch assemblies 2 and 3 control three variables; gate length, counts per gate and consecutive gates required for a fire output. Refer to Figure 21 for a visual representation of how these variables function together with typical controller settings. Keep in mind that when the UV and IR sensors of the detector respond to a fire, the IR sensor activates the circuitry in the UV/IR detector junction box. This allows the electrical pulses (signal) from the UV sensor to be sent to the controller. The frequency of this signal is proportional to the intensity of the fire. The controller looks at this signal in comparison to the sensitivity settings in order to determine whether a fire exists. A brief description of each variable follows:

1. Gate Length is adjustable from 31.25 milliseconds to 8 seconds. The gate length is the increment of time that the controller looks at the detector signal to determine if the "Counts per Gate" requirement is fulfilled. In Figure 21, the gate length is 0.25 seconds (Rocker Switch 2-4 closed, Rocker Switches 2-1, 2-2, 2-3, 2-5, 2-6, 2-7, and 2-8 open).
2. Counts per Gate is adjustable from 2 to 15 counts. These counts make up the signal from the detector and are a direct response to a flame or other UV/IR source. In Figure 21, the counts per gate setting is 4 counts (Rocker Switch 3-3 closed, Rocker Switches 3-1, 3-2, and 3-4 open).
3. Consecutive Gates required for a fire output are adjustable from 2 to 15 gates. This is the number of consecutive gates in which the "Counts per Gate" requirement is fulfilled that the controller must see before going into a fire alarm condition. In Figure 21, the consecutive gates setting is 4 gates (Rocker Switch 3-7 closed, Rocker Switches 3-5, 3-6, and 3-8 open).

If changes in the sensitivity and/or time delay settings are required, read the detailed discussions of each of the three STAR Logic variables that follows before making changes. When changing the settings, keep in mind the following guidelines:

1. Increasing Gate Length while the other variables remain unchanged results in higher sensitivity and a longer time delay.
2. Increasing Consecutive Gates while the other variables remain unchanged results in a longer time delay and greater noise immunity.
3. Increasing Counts per Gate while the other variables remain unchanged results in lower sensitivity and greater false alarm rejection.

Gate Length - Rocker Switches 2-1 to 2-8

The gate length can be adjusted in 31.25 millisecond increments from 31.25 milliseconds to 8 seconds. Each rocker selects a particular time value. The gate length is the value of all rockers closed, added together. If no rocker is closed, the controller will select the minimum length (31.25 milliseconds). The typical gate length settings used in most applications are between 0.125 and 0.5 second.

- Rocker 2-1 - 31.25 milliseconds
- Rocker 2-2 - 62.5 milliseconds
- Rocker 2-3 - 0.125 second
- Rocker 2-4 - 0.25 second
- Rocker 2-5 - 0.5 seconds
- Rocker 2-6 - 1 seconds
- Rocker 2-7 - 2 seconds
- Rocker 2-8 - 4 seconds

The value of the closed switches are added together to obtain the total time delay.

Count Selection - Rocker Switches 3-1 to 3-4

When a gate length of less than 0.5 second, the rockers select counts needed per gate for a fire signal. The values of all rockers closed are added together. If no counts or less than 2 counts are selected (only rocker 1 closed), the microprocessor will select 2. Counts per gate are selectable in 1 count increments from 2 to 15 counts. The typical counts per gate setting used in most applications are between 2 and 8 counts.

- Rocker 3-1 - 1 count
- Rocker 3-2 - 2 counts
- Rocker 3-3 - 4 counts
- Rocker 3-4 - 8 counts

When a gate length of 0.5 second or greater is used, the programmed counts per gate value is multiplied by a factor that is determined by the gate length that has been programmed using rocker switches 2-5 to 2-8. Refer to Figure 22 to determine the proper multiplication factor. Note that the multiplication factor is determined by the highest numbered rocker switch in the closed position.

The STAR logic program uses this multiplication technique to prevent accidental programming of a very low count value combined with a long gate length, since this combination would result in an extremely high sensitivity level that would increase susceptibility to false alarms.

For example, suppose that a gate length of 1.5 seconds and a sensitivity of 4 counts per gate is selected. Since the gate length exceeds 0.5 second, the counts per gate value must be multiplied by the factor determined

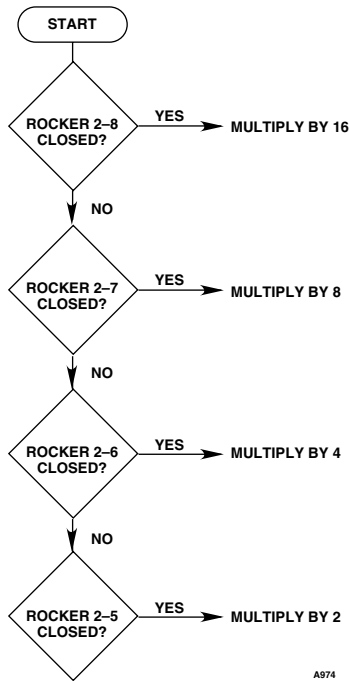

Figure 22—Multiplication Factors

from Figure 22. In this case, 4 counts per gate is multiplied by a factor of 4, to obtain a total programmed value of 16 counts per gate. Without this feature, it would be possible to program the system to interpret 4 counts in 1.5 seconds as a fire signal, which would make the system susceptible to frequent false alarms.

Consecutive Gate Selection - Rocker Switches 3-5 to 3-8

These rockers select the number of consecutive gates required for a fire signal. Consecutive gates are selectable in 1-gate increments from 2 to 15 gates. If fewer than 2 gates are selected (only rocker 5 closed), the microprocessor will select 2. The values of the rockers closed are added together. The typical consecutive gate settings used in most applications are between 3 and 8 gates.

- Rocker 3-5 - 1 Gate
- Rocker 3-6 - 2 Gates
- Rocker 3-7 - 4 Gates
- Rocker 3-8 - 8 Gates

Detector Grouping/Voting Logic Selection 4-1 to 4-4

Rocker switches 4-1 to 4-4 are used to program the controller for the particular voting arrangement to be used. (Refer to the "System Description" section of this manual for a description of the options available with the Detector Grouping/Voting Logic feature.) Refer to Figure 20 (Switch Assembly 4) to determine the correct positions for rocker switches 4-1 to 4-4.

NOTE

When in the Normal mode and the outputs are set for non-latching operation, the voting process will actuate the Fire Logic output(s) only if the pre-selected number of detectors "see" fire at the same time. When the outputs are set for latching operation, the voting process will actuate the Fire Logic output(s) when voting criteria have been met, even if a fire is not being seen by each detector at the same time.

Detector Grouping - Rocker 4-1

- Separate - closed
- Combined - open

When rocker switch 4-1 is closed, detectors 1 to 4 activate the Alarm 1 and Fire Zone 1 outputs, and detectors 5 to 8 activate the Alarm 2 and Fire Zone 2 outputs.

When rocker switch 4-1 is open, a fire at any of eight detectors causes actuation of both Alarm outputs. Fulfillment of the programmed voting requirements results in actuation of both Fire Zone outputs.

Voting Selection - Rockers 4-2 to 4-4

Rocker switches 4-2 to 4-4 are used to program the controller for the particular voting logic arrangement to be used. Refer to the "Description" section of this manual for a description of the options available with the voting logic feature. Then refer to the Voting Selection Table (Table 3) to determine the correct switch positions.

Separate — For two separate voting groups:

- 4-1 is closed
- 4-2 is not used in this voting arrangement
- 4-3 programs Fire Zone output 2 (channels 5, 6, 7, 8)
 - open, any one detector
 - closed, any two detectors
- 4-4 programs Fire Zone output 1 (channels 1, 2, 3, 4)
 - open, any one detector
 - closed, any two detectors

Table 3—Voting Selection Table

SWITCH ASSEMBLY 4 VOTING LOGIC							
ROCKER POSITION				FIRE ZONE OUTPUTS		DETECTOR RESPONSE	
4-1	4-2	4-3	4-4				
CL	DC	DC	OP	1		1	1 DETECTOR
CL	DC	DC	CL	1		2	2 DETECTORS
CL	DC	OP	DC	2		1	1 DETECTOR
CL	DC	CL	DC	2		2	2 DETECTORS
OP	ALL OPEN			1*2		1	1 OF 8 DETECTORS
OP	1 CLOSED			1*2		2	2 OF 8 DETECTORS
OP	2 CLOSED			1*2		3	3 OF 8 DETECTORS
OP	3 CLOSED			1*2		4	4 OF 8 DETECTORS
OP = OPEN, CL = CLOSED, DC = DON'T CARE 1*2 = 1 AND 2							

Common— For up to eight channels voting, and Fire Zone outputs 1 and 2 energized simultaneously:

4-1 is open

4-2, 4-3, 4-4 - All open = any one detector

Any one closed = any two detectors

Any two closed = any three detectors

All three closed = any four detectors

Outputs Latching/Non-latching - Rocker Switch 4-5

Once energized, an output will remain on (latching) until the controller is reset if rocker 4-5 is set open.

Rockers 4-6, 4-7 and 4-8 are not used.

When the proper position for each of the rocker switches has been determined, record this information carefully on the system layout chart in Figure 23. This provides a means of double checking switch positions before power is applied to the controller, and to provide a record of switch positions for future reference.

TYPICAL SYSTEM APPLICATION

The following application is an example only. For assistance in adapting a system to your individual requirements, contact the Field Support Group at Detector Electronics.

Power is supplied to the system by a 24 volt dc power supply. A four conductor shielded cable is used to connect the detectors to the controller as shown in Figure 14. Terminals A and C (power connections) are common to all the detectors in the system. The B- and D-leads of each detector are connected to their corresponding "B" and "D" terminals on the controller. The shields are tied together and grounded at terminal 33. A 0.47 microfarad, 250 volt capacitor is placed between terminal 5 and terminal 2. A remote reset switch is provided for resetting the controller or inhibiting the outputs from a remote location. The connections are made to terminals 31 and 32.

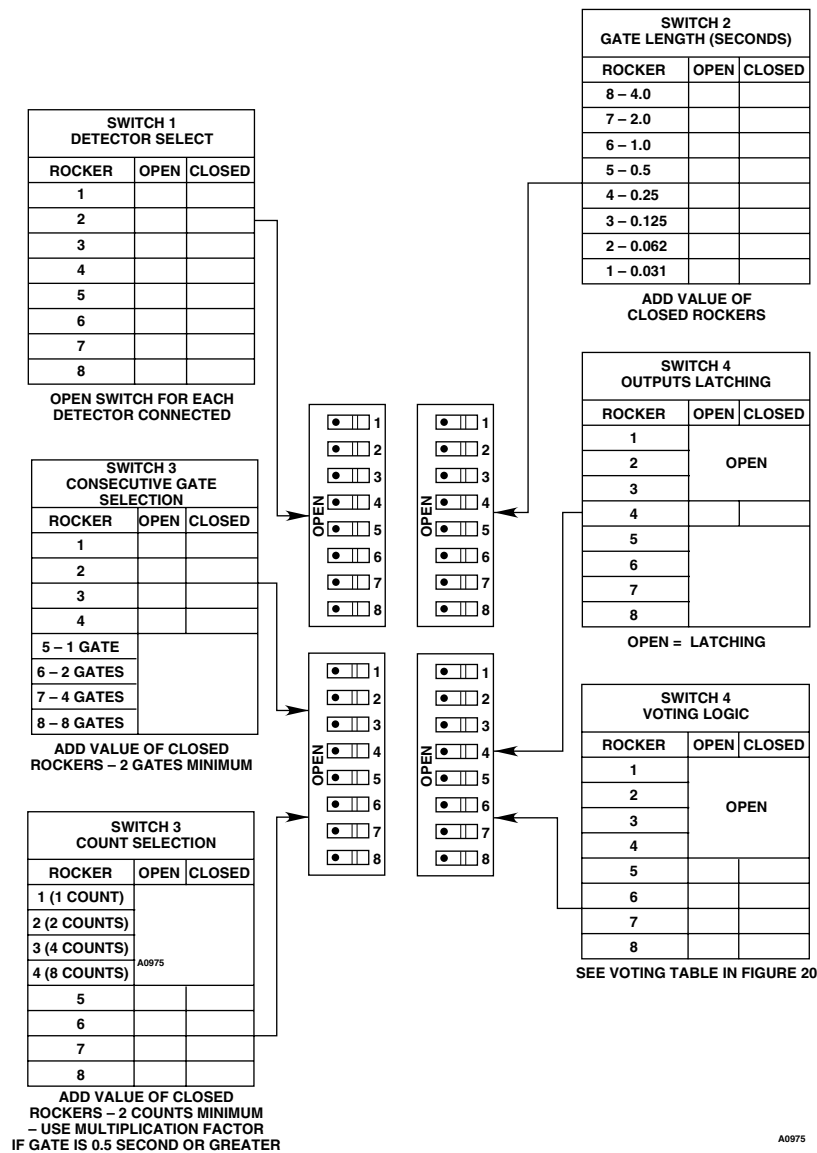

Figure 23—System Layout Chart

Power is connected to a load circuit through the normally closed contacts of the Alarm relay. Detection of a fire causes the contacts to open and remove power from the load. If the pre-programmed voting requirements are met, power is applied to an extinguishing load through the Fire Zone relay. Power is connected to a process control circuit through the normally energized Fault relay. In the event of a system fault or when the controller is in the Test mode, the contacts open and remove power from the process. An annunciation device is connected to the power source through the Fault relay to provide a visual or audible warning of a system failure.

STARTUP PROCEDURE

The startup procedure should be performed after installation of the equipment is complete.

1. After making the electrical connections and setting the switches, plug the controller into the wiring connector.
2. Disable any extinguishing system connected to the system.
3. Turn on the input power to the system and perform the "Initial and Periodic Checkout Procedure."
4. If the controller is operating normally and is programmed correctly, remove any mechanical blocking devices and restore power to the extinguishing loads.

INITIAL AND PERIODIC CHECKOUT PROCEDURE

The entire system should be periodically checked with a UV/IR test lamp to be sure that the detectors are not obstructed, that the area "seen" by the detector has not changed, and that there is no fault in the oi circuit.

1. Place the Mode switch in the TEST position. The FAULT LED will be illuminated.

CAUTION

Placing the controller in the Test mode inhibits the outputs, rendering the system incapable of actuating any extinguishing or alarm circuits that are connected to it. However, for maximum safety, secure the output loads that would normally be actuated by the system before performing the checkout procedure.

2. Shine the UV/IR test lamp into the viewing window of the detector under test. The ALARM LED is illuminated and the corresponding DETECTOR LED blinks.

3. If the voting requirements are met, the appropriate FIRE ZONE LED(s) is also illuminated.
4. Turn off the UV/IR source. The FIRE ZONE LED remains on if it was previously illuminated. The DETECTOR LED remains on, but stops blinking.
5. Repeat steps 2 through 4 for each detector in the system.
6. After all detectors have been checked, reset the system by placing the Mode switch in the NORMAL position. All LEDs except the POWER LED are off.
7. Restore power to the output loads and remove any mechanical blocking devices.

Star Programming Checkout Procedure

1. Secure output loads (remove power from valves, relays or other devices that might otherwise be actuated by the UV/IR system) before testing.
2. Apply power to the UV/IR detection system.
3. Ensure that the area being monitored is operating under normal conditions (equipment that would normally be on is on).
4. Place the UV/IR controller toggle switch in the NORMAL position and monitor for one hour.
 - If the rockers have been set correctly, transient radiation in the area should not activate the system. The upper and lower LED displays should remain dark. If this is the case, lower (more sensitive) settings can be attempted.
 - If the system sensitivity is set too high, one of the eight DETECTOR LEDs will turn on and the appropriate FIRE ZONE LEDs will turn on if voting requirements are met. If this happens, set the rocker switches for more counts per gate, for more consecutive gates required for actuation, or for a shorter gate length and repeat the test. Altering detector placement may also decrease the susceptibility of the system to transient radiation.

For further assistance, contact the Field Support Group at Detector Electronics.

MAINTENANCE

The C7052J Detector requires no periodic calibration. However, to maintain maximum sensitivity, the detector viewing windows must be kept clean at all times. Even a small amount of certain UV or IR absorbing materials

(sometimes barely detectable to the human eye) can significantly reduce the sensitivity of the detector. The windows and **o**i rings should be thoroughly cleaned on a regular basis. The length of time between periodic cleanings will be determined by the nature and amount of contaminants present in the environment.

Remove the **o**i rings by squeezing the tabs together and pulling away from the detector. Clean the viewing windows thoroughly, all the way to the edge. Also clean the reflective surface of the **o**i rings (the surface of the ring that faces the detector viewing window). When re-installing an **o**i ring, hold it by its tabs to avoid leaving fingerprints on the reflective surface. Re-install the ring so that the opening is pointed down to prevent a buildup of contaminants. If corrosive contaminants in the atmosphere cause the reflective rings to deteriorate to the extent that it is no longer possible to restore them to their original condition, they must be replaced.

Det-Tronics window cleaning solution (part number 001680-001) is designed specifically for cleaning the optical surfaces of the detector. DO NOT use commercial cleaners. These products can leave a residue on the surface that is intended to give it a “sparkling” look, however, this residue can substantially attenuate the radiation reaching the sensor.

Use a clean cloth or tissue to clean the window. DO NOT use commercial glass cleaning tissues, since many of these contain a silicone substance that remains on the window after cleaning. Silicone readily absorbs radiation and can effectively “blind” the detector, even though the window appears to be clean.

NOTE

When cleaning the detector windows, remove input power or place the system in the “Bypass” or “Reset/Inhibit” mode. Rubbing motion on the surface of the windows during cleaning can create an unwanted output activation.

Viton O-rings on each of the detector housings are used to ensure the watertight integrity of the detector. Periodically, the housing should be opened and the O-rings inspected for breaks, cracks, and dryness. To test them, remove the rings from the detector housing and stretch them slightly. If cracks are visible, the ring should be replaced. If they feel dry to the touch, a thin coating of lubricant should be applied. When re-installing the rings, be sure that they are properly seated in the groove on the housing. It is imperative that these O-rings be properly installed and in good condition. Failure to maintain these rings can allow water to enter the detector and cause premature failure. The life expectancy of Viton O-rings can vary considerably, depending on the amount and

nature of contaminants that are present in the environment. The individual responsible for maintenance of the system must rely on experience and common sense to determine how frequently the rings should be inspected.

The recommended material for lubricating the O-rings is a silicone free polyalphaolefin grease, part number 005003-001, available from Detector Electronics. A coating of lubricant should also be applied to the threads on the sensor housings before reassembling the detector. This will both lubricate the threads and help to prevent moisture from entering the detector housing.

Refer to “Recommended Spare Parts” in the “Ordering Information” section of this manual for a list of products available from Detector Electronics for maintenance of the detector.

Sensor Module Replacement Procedure

To replace a defective module:

CAUTION

Do not open the detector housing in a hazardous location without first removing power.

- a. Remove power from the detector.
- b. Remove the sensor housing (see Figure 12).
- c. Remove the sensor module.
- d. Determine the proper orientation for the new sensor module (with the **o**i test lamps positioned at the top or side of the detector), then install the module. Attach the connector plug (DE5500 models of the IR sensor only).
- e. Ensure that the O-rings at the base of the sensor housing are positioned correctly and in good condition. (Refer to the “Maintenance” section of this manual for complete information regarding care of O-rings.)
- f. Re-install the sensor housing. Hand tighten the sensor housing into the base until the O-ring is fully seated to ensure explosion-proof and watertight integrity of the housing.
- g. Inspect the viewing windows and **o**i rings and clean if necessary. Also check the position of the **o**i rings.
- h. Perform the “Startup Procedure” before returning the system to normal operation.

TROUBLESHOOTING

Table 4 is intended to serve as an aid in locating the source of a system malfunction. The R7495B Controller is not designed to be repaired by the customer in the field, but should be returned to the factory in the event of a malfunction. Refer to the "Maintenance" section of this manual for information regarding servicing of the detector.

DEVICE REPAIR AND RETURN

Prior to returning devices or components, contact the nearest local Detector Electronics office so that an RMI (Return Material Identification) number can be assigned. A written statement describing the malfunction must accompany the returned device or component to expedite finding the cause of the failure, thereby reducing the time and cost of the repair to the customer. Return all equipment transportation prepaid to the factory in Minneapolis.

Detector Electronics Corporation
 6901 West 110th Street
 Minneapolis, Minnesota 55438 USA
 Operator: (952) 941-5665 or (800) 765-FIRE
 Customer Service: (952) 946-6491
 Fax: (952) 829-8750
 Web site: www.detrionics.com
 E-mail: detrionics@detrionics.com

Table 4—Troubleshooting Guide

Problem	Possible Cause
No POWER LED	<ol style="list-style-type: none"> 1. Input power failure. 2. Wiring to external power source 3. Controller power supply failure.
FAULT LED on	<ol style="list-style-type: none"> 1. Mode switch in TEST position. 2. Low input voltage.
FAULT LED and a DETECTOR LED on	<ol style="list-style-type: none"> 1. oi fault - dirty window and/or the oi ring 2. Detector module has lost sensitivity 3. Detector wiring problem
FAULT LED off, DETECTOR LED blinking slowly	<ol style="list-style-type: none"> 1. Detector responding to UV/IR source not large enough to exceed the fire threshold programmed into the controller
ALARM LED on, no actuation of outputs	<ol style="list-style-type: none"> 1. Mode switch in TEST position. 2. Output circuit failure.

ENGINEERING SPECIFICATIONS

The UV/IR flame detection system shall have a micro-processor-based controller that can operate up to 8 detectors and provide relay outputs through the use of a relay output module. The controller shall be field programmable for selecting time delay length, sensitivity, voting output configuration, and latching or non-latching operation. The system shall operate on 24 vdc. The UV/IR flame detection system shall be capable of responding to a 1 foot by 1 foot gasoline fire at a distance of 50 feet. The detector shall be capable of 1.0 second response time to an intense fire signal. It shall not respond to radiation generated by arc welding, x rays, or hot surfaces, but shall be capable of responding to a fire in their presence. The UV/IR flame detector shall be in a red, copper-free aluminum enclosure. The detector shall be the Det-Tronics model C7052J, no equal. The controller shall be the Det-Tronics model R7495B Controller and the that fits in the Det-Tronics model Q4004 Mounting Rack which is designed to fit standard 19" racks, no equal.

The UV/IR flame detector shall have one 3/4" NPT² entry for field wiring.

The controller shall have visual annunciation of fire and fault conditions. The controller shall have eight red LEDs for individual detector alarm indications, one green LED for power indication, one yellow LED for fault indication, one red LED to indicate an alarm, and two red LEDs for fire zone (voting) output indication.

The signal processing shall require the UV radiation and the flickering IR radiation to exceed field adjust threshold levels and time delay before signalling an alarm condition. The detector shall have a 80 degree cone of vision and be of a modular plug-in design that allows the UV and IR sensor modules to be easily field replaced without the use of special tools. All optical surfaces shall be easy to access for cleaning. No metal rods shall be allowed in front of the sensor windows.

The UV/IR flame detector shall have optical testing capabilities on both the UV and IR sensor. Films that blind the UV sensor or the IR sensor shall cause a failure of the optical test.

The UV/IR flame detector shall be rated for an operating temperature range of -40°F to +167°F (-40°C to +75°C) and a storage temperature of -40°F to +185°F (-40°C to +85°C). The detector shall operate over a humidity range of 0 to 95% RH and be able to withstand 100% condensing humidity for short periods of time. All printed circuit boards shall be coated to provide protection from the environmental conditions. The UV/IR flame detector shall meet MIL-STD 810C for vibration and

have a swivel mounting bracket to provide a means to easily mount and aim the detector.

The UV/IR flame detector shall be explosion-proof for Class I, Division 1, Groups B, C and D; Class II, Division 1, Groups E, F and G. The device shall be rated NEMA 4 (dust-tight, watertight). The detector shall be FM approved³.

An explosion-proof UV/IR test lamp shall be provided to allow field testing of the UV/IR flame detection system. The test lamp shall be FM approved for use in Class I, Division 1, Groups C and D hazardous areas. The explosion-proof UV/IR test lamp shall be the Det-Tronics model W867, no equal.

The following options can be substituted for the item in bold:

- 1 or: "in a 316 stainless steel enclosure."
- 2 or "25 mm"
- 3 or: "flame-proof for EEx d IIB. The device shall be rated IP66 (dust-tight/water-tight). The detector shall be BASEEFA/CENELEC certified."
- or: "explosion-proof for Class I, Division 1, Groups C and D; Class II, Division 1, Groups E, F and G. The device shall be rated NEMA 4 (dust-tight, watertight). The detector shall be CSA certified."

ORDERING INFORMATION

When ordering, specify:

- R7495B Controller
- C7052J Detector
- Number detectors needed
- Detector housing materials
 - Anodized copper-free aluminum
 - 316 stainless steel
- Approvals required
 - FM
 - CSA
 - BASEEFA/CENELEC

ACCESSORIES

- Q4004 Mounting Cage accommodates eight modules (Controllers) and fits standard 19-inch instrument rack. Smaller sizes are available.
- Filler panels for empty spaces in the Q4004 Mounting Cage
- 000507-XXX power supplies
- Cover locking assembly
- Q1113 Air Shields
- W867 UV/IR Test Lamp
- Q9001G Swivel Assembly

RECOMMENDED SPARE PARTS

Description	Part Number	Quantity
UV oi rings	002519-001	2 per 10 detectors
IR oi rings	003525-001	2 per 10 detectors
UV Sensor Module	DE1888	1 per 10 detectors
IR Sensor Module (plug-in type)	003895-001	1 per 10 detectors
	003895-002	1 per 10 detectors
IR Sensor Module (wire harness type)	005500-001	1 per 10 detectors
Junction box circuit board	0004432-001	1 per 10 detectors
O-rings	107427-004	4 per 10 detectors
Grease (silicone-free)	005003-001	1 per 10 detectors
Window Cleaner Kit (six bottles)	001680-001	

APPLICATION ASSISTANCE

For assistance in ordering a system to fit your application, please contact:

Detector Electronics Corporation
 6901 West 110th Street
 Minneapolis, Minnesota 55438 USA
 Operator: (952) 941-5665 or (800) 765-FIRE
 Customer Service: (952) 946-6491
 Fax: (952) 829-8750
 Web site: www.detronics.com
 E-mail: detronics@detronics.com